

**TANCO AUTOWRAP  
1060A MODEL 1996  
C/W "TWIN-PAK" LOADING ARM  
OPERATORS HANDBOOK  
AND  
PARTS LIST  
WD65-1060-ATP-M0396**



### GUARANTEE

Subject as hereunder provided, the Sellers undertake to correct either by repair or at their election by replacement any defect of material or workmanship which occurs in any of its goods within twelve months after delivery of such goods to first user, with the exception of contractors or commercial users when warranty period is six months.

In respect of Autowraps the warranty period is for 12 months or 8000 bales which ever occurs first.

In respect of Aerways tine breakage will be assessed on an individual basis in every case.

The term goods when used in this document means the article or articles described in invoice as sold by the sellers but does not include equipment or proprietary parts or accessories not manufactured by the sellers. The sellers, however, undertake to pass on so far as they legally can to the first user the benefit of any warranty given to the Sellers by the suppliers of such equipment, parts or accessories.

This understanding shall not apply to:

- (a) Any goods which have been sold by the first user.
- (b) Any goods which have been injured by unfair wear and tear, neglect or improper use.
- (c) Any goods the identification marks of which have been altered or removed.
- (d) Any goods which have not received the basic normal maintenance such as tightening of bolts, nuts, tines, hose connections and fittings and normal lubrication with the recommended lubricant.
- (e) The use of any product on tractors exceeding the recommended horsepower.
- (f) Any goods which have been altered or repaired other than on instruction or with the written approval of the Seller or to which any part not manufactured or having written approval by the Sellers have been fixed.
- (g) Any second-hand goods or part thereof.

Any allegedly defective part or parts returned to the Sellers must be sent carriage paid. No claim for repair or replacement will be entertained unless upon discovery of the alleged defect written notification is sent to the Sellers giving, at the same time, the name of the Buyer from whom the goods were purchased and the date of purchase together with full details of the alleged defect and the circumstances involved, also the serial number of the machine etc.,

The Sellers shall be under no liability to their Buyers and first and subsequent users of their goods or to any other person or persons for loss or damages howsoever arising in respect of either personal injuries or for arising out of, or in any way connected with or arising from the manufacturers sale, handling, repair, maintenance, replacement or use of its goods or the failure or malfunction of any of its goods.

Representation and/or warranties made by any person (including Buyers and employees and other representatives of the Seller) which are inconsistent or conflicting with these conditions are not binding upon the Sellers unless given in writing and signed by a Director of the Sellers.

### CLAIMS

If you wish to make a claim under guarantee.

1. Immediately, stop using the machine.
2. List the details of the machine, its serial number and the part number of the damaged part.
3. Consult with your Tanco dealer (supplier) and have him forward your claim and the damaged item to Tanco.

1060A MODEL C/W "TWIN-PAK" LOADING ARM

<u>INDEX</u>	<u>1060A MODEL</u>	<u>PAGE NO.</u>
GENERAL SAFETY INSTRUCTIONS		1/2/3
SAFETY INSTRUCTIONS		4
SAFETY DECALS		5
TECHNICAL SPECIFICATIONS		6
PRE DELIVERY INSTRUCTIONS		7/8
TRANSPORT INSTRUCTIONS		9
MACHINE IDENTIFICATION		9
PREPARATION OF A NEW MACHINE		9
HYDRAULIC CONNECTIONS		9
JUNCTION BOX AND CONTROLLER FOR 5 BANK VALVE		10
AUTOMATIC BALE WRAP CONTROLLER		11
OPERATOR ACCESSIBLE MONITOR PROGRAMMES		12/13/14
MODE OF OPERATION		15
OPERATING INSTRUCTIONS		16
WARNING; LIFT ARM		17
OPERATING INSTRUCTIONS "TWIN-PAK" LOADING ARM		18
"TWIN-PAK" LOADING SEQUENCE		19
FILM OVERLAP SYSTEM		20
SERVICE AND MAINTENANCE		21/22
FILM THREADING DIAGRAM		23
GEARBOX CHAIN DRIVE TENSIONING SYSTEM		24
TURNTABLE CHAIN DRIVE TENSIONING SYSTEM		25
BALE BELT TRACKING		26
BALE BELT TRACKING ILLUSTRATED		27
HYDRAULIC CIRCUIT DIAGRAM 1060A MODEL		28
HYDRAULIC COMPONENTS 1060A MODEL		29
PARTS LIST FOR ABOVE		30
FITTING 2 WAY SOLENOID VALVE		31
"TWIN-PAK" LIFT ARM HYDRAULIC COMPONENTS		32
"TWIN-PAK" ELECTRICAL COMPONENTS		33
PARTS LIST FOR ABOVE		34
CONSTANT INDEXING DRIVE ASSY		35
PARTS LIST FOR ABOVE		36
AUTOWRAP ILLUSTRATED		37
PARTS LIST FOR ABOVE		38
TURNTABLE CHAIN DRIVE ASSEMBLY		39
PARTS LIST FOR ABOVE		40
BALE BELT ROLLER MOUNTING BRACKETS		41
PARTS LIST FOR ABOVE		42
FILM DISPENSING SYSTEM 1060A MODEL		43
PARTS LIST FOR ABOVE		44
VALVE/JUNCTION BOX/FILTER & DIVERTER VALVE MOUNTING BRACKET ASSEMBLY		45
END ROLLER MOUNTING BRACKET		46
"TWIN-PAK" LIFT ARM ASSEMBLY		47
PARTS LIST FOR ABOVE		48
HYDRAULIC BALE RAMP		49
PARTS LIST FOR ABOVE		50
FAULT FINDING SUMMARY		51
CUT AND START UNIT ILLUSTRATED		52
PARTS LIST FOR ABOVE		53
SLIP RING ASSY		54
SENSOR MAGNET MOUNTING BRACKETS		55
CUT AND START FAULT FINDING SUMMARY		56
OPTIONS AVAILABLE		57
LIGHTING KIT		58

Fig 1 - Page no. 23  
 Fig 2 - Page no. 24  
 Fig 3 - Page no. 24  
 Fig 5 - Page no. 22  
 Fig 7 - Page no. 11  
 Fig 8 - Page no. 25  
 Fig A - Page no. 16

Fig 10 - Page no. 19  
 Fig 11 - Page no. 19  
 Fig 12 - Page no. 19  
 Fig 13 - Page no. 19

## GENERAL SAFETY RECOMMENDATIONS

Before operating the machine, always ensure that the tractor and machine meet with work safety and road traffic regulations.

### BASIC PRINCIPLES

- 1: In addition to the recommendations given in this manual, legislation on work safety and accident prevention must also be respected.
- 2: Advice is indicated on the machine, specifying safety recommendations in order to prevent accidents.
- 3: Before travelling on public roads, the operator must ensure that the machine conforms to road traffic regulations.
- 4: Before starting work, the operator must be familiar with all machine controls, handling devices and their functions. Once at work, it is too late to do this!
- 5: Do not wear loose clothing which could become caught up in moving elements.
- 6: The tractor should be equipped with a safety cab.
- 7: Before starting up the machine and beginning work, check the surrounding area (beware of children!). Make sure there is sufficient visibility. Keep all people and animals away from the danger zone of the machine (risk of projection!).
- 8: Carrying people or animals on the machine when working or in transport is strictly forbidden.
- 9: Machine must only be attached to tractor using means provided and in accordance with current safety standards.
- 10: Special care should be taken when attaching or removing the machine from the tractor.
- 11: Before transporting the machine on public roads, ensure that all legally required guards and indicators (lights, reflectors ...) are in place and in good operation.
- 12: All operating controls (cords, cables, rods etc.) must be positioned so that they cannot be set off accidentally, risking accident or damage.
- 13: Before travelling on public roads, put the machine into its transport position as instructed in this operators manual.
- 14: Never leave the tractor seat while the machine is operating.
- 15: Drive speed must be adapted to ground conditions as well as to roads and paths. Always avoid abrupt changes of direction.
- 16: Before operating the machine, ensure that all safety guards are firmly in place and in good condition. If worn or damaged, replace immediately.
- 17: Before operating the machine, check the tightness of all nuts and bolts, particularly on fixing elements (blades, tines, knives, spades etc.,).
- 18: Keep clear of the machine operating area.
- 19: **WARNING!** Danger of crushing and shearing can exist when components are operated by hydraulic or pneumatic controls.
- 20: Before leaving the tractor or before adjusting, maintaining or repairing the machine, turn off the engine, remove the ignition key and wait until all moving parts have come to a complete stop.

- 21: Do not stand between the tractor and the machine unless the hand brake is tight and/or stops have been placed under the wheels.
- 22: Before any adjustments, maintenance or repairs are carried out, ensure that the machine cannot be started up accidentally.

#### **ADDITIONAL RECOMMENDATIONS FOR LINKAGE MOUNTED MACHINES**

- 1: Before attaching the machine, ensure that the front tractor axle is sufficiently ballasted. Ballast is to be placed on the supports provided in accordance with instructions of the tractor manufacturer.
- 2: Do not exceed the maximum axle load or the overall transport weight prescribed by the tractor manufacturer.
- 3: Precision steering, tractor adherence, road holding and efficient braking are influenced by the type of implement, weight, ballast of front axle, ground or road conditions. It is therefore of utmost importance to be cautious in every given situation.
- 4: Be particularly cautious when turning corners, paying attention to machine overhang, length, height and weight.

#### **SAFETY RECOMMENDATIONS FOR ATTACHING IMPLEMENTS TO TRACTOR**

- 1: When attaching or removing the machine from the tractor, position hydraulic lift control lever in such a way that it cannot be set off accidentally.
- 2: When attaching the machine to the tractor hydraulic linkage, ensure that diameter of the link pins corresponds to the diameter of the ball joints.
- 3: **WARNING!** Danger of crushing and shearing can exist in the lifting zone of the tractor hydraulic linkage!
- 4: Do not stand between the tractor and the machine when operating the outer lever of the lift mechanism.
- 5: In transport, the machine lift mechanism should be stabilized by tractor tie rods to avoid floatation and side shifting.
- 6: When transporting the machine, lock the hydraulic lift control lever in place so that it cannot be lowered accidentally.

## HYDRAULIC SYSTEM

- 1: **WARNING!** Hydraulic system is under pressure.
- 2: When fitting hydraulic motors or cylinders, ensure that connections have been made correctly, as per manufacturers instructions.
- 3: Before connecting hoses to the tractor hydraulics, ensure that tractor and machine circuits are not under pressure.
- 4: It is strongly recommended that the operator marks the hydraulic connections between tractor and machine to avoid making a wrong connection.  
**WARNING!** Functions could be reversed (for example: lift/lower).
- 5: Check hydraulic hoses regularly! Worn or damaged hoses must be replaced immediately. Replacement parts must be in accordance with the manufacturers recommendations concerning specifications and quality.
- 6: Should a leak be found, take all necessary precautions to avoid accidents.
- 7: Any liquid under pressure (particularly oil from hydraulics) can penetrate the skin and cause severe injury. If injured, see a doctor immediately, there could be a danger of infection.
- 8: Before any adjustments, maintenance or repairs are carried out, lower the machine, depressurize the circuit, turn off the engine and remove the ignition key.

## MAINTENANCE

- 1: Before checking for any machine malfunction and before adjusting, maintaining or repairing the machine, turn off engine and remove ignition key.
- 2: Check tightness of nuts and bolts regularly. Retighten if necessary.
- 3: If the machine is raised, prop it up in a stable position before carrying out any maintenance work.
- 4: When replacing a working part, wear protection gloves and use only standardized tools.
- 5: It is forbidden to discard any oil, grease or filters. These must be given to waste disposal organisations to protect the environment.
- 6: Disconnect power source before any work is done to the electric system.
- 7: Check safety guards regularly, particularly those that are subject to wear. Replace immediately if damaged.
- 8: Spare parts used must be in accordance with specifications and standards as defined by the manufacturer. Use only genuine TANCO parts.
- 9: Before any electric welding is carried out on tractor or attached machine, disconnect generator and battery terminals.
- 10: Repairs on elements under pressure or tension (springs, accumulators etc.) must only be carried out by competent persons with standardized equipment.

### SPECIAL SAFETY INSTRUCTIONS

1. Stop engine of tractor before working on machine.
2. Put a suitable prop under raised platform before working in this area.
3. Always raise Lift Arm and fit safety prop before transporting machine on public roads.
4. Lift Arms should always be lowered before operating turntable.
5. Ensure platform rollers are parallel to Lift Arm before arm is raised.
6. On Autowrap models fitted with hydraulic bale ramp it is essential that the hydraulic hose is not disconnected from the hydraulic cylinder or hydraulic accumulator. This system is charged under pressure. Also, do not attempt to open the hydraulic accumulator as this is a pressurised unit.

### OPERATING SAFETY INSTRUCTIONS

1. Operators should have their hands on the controls at all times when machine is in use.
2. Autowrap control unit and level controls must remain in the tractor cab at all times. The operator must at no time leave the tractor cab when the machine is in motion.
3. Keep onlookers clear of machine at all times. Danger zone is 5 metres.
4. Beware of rotating turntable and all moving parts.
5. If not operated correctly the bale could fly off the turntable. The end support rollers must always be fitted. Do not exceed recommended turntable speed of 30 r.p.m. Mis-shapen bales combined with excessive turntable speeds can be dangerous.
6. Care must be taken when tipping bales from machine on sloping ground and during subsequent handling to ensure that they do not roll, thus causing hazard.

THINK OF YOUR PERSONAL SAFETY AND THAT OF OTHERS AT ALL TIMES.

# SAFETY DECALS

The following safety decals have been placed on your machine in the areas indicated. They are intended for your personal safety and for the safety of the people working with you. With this manual, walk around your machine and note the content and location of these warning signs. Review these decals and the operating instructions in the manual with your machine operators.

Ensure that these decals are always legible. If they are not, replace them.

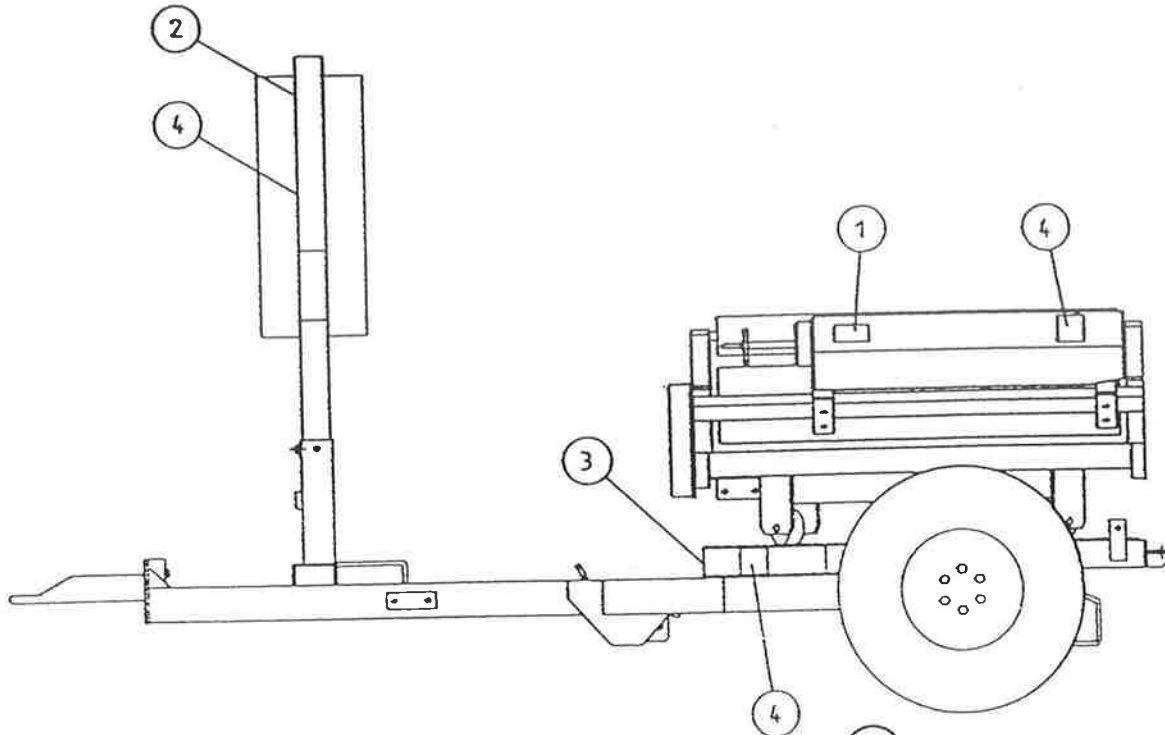

WARNING SHARP KNIFE

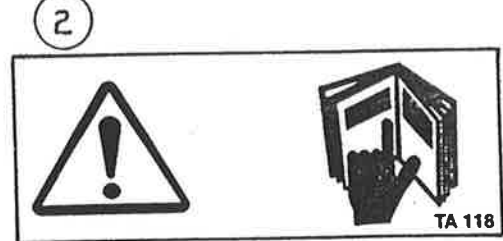

BEFORE STARTING THE MACHINE READ OPERATORS MANUAL AND SAFETY INSTRUCTIONS



20 R.P.M. MAX.

DO NOT EXCEED TURNTABLE SPEED OF 20 R.P.M



DANGER STAND CLEAR

## TECHNICAL SPECIFICATIONS

### 1060S/1060A MODELS C/W "TWIN-PAK" LOADING ARM

#### Dimensions

Total Length - Excluding Bale Ramp	...	350cm
Width - excluding lift arm	...	221cm
Width - lift arm fully raised	...	243cm
Width - lift arm lowered	...	406cm
Height to top of side (bale guide) rollers	...	110cm
Height to top of lift	...	220cm

#### Weight

With lift arm	...	1230kgs
Without lift arm	...	1100kgs

#### Wheels

Size	...	10-80.12
Pressure	...	42 p.s.i.

Lift arm capacity - Axle extended normally	...	500kgs
Lift arm capacity - Axle extended fully	...	650kgs
Speed of turntable	...	20 rev/min*
Oil requirement	...	23litres/min (165 kp cm <sup>2</sup> )
Attachment to tractor	...	Tractor Hitch
Bale sizes "Square Bales"	...	Up to 1.7m
New Holland D1000, D1010		
New Holland D710 (in pairs)		
Welger D4000		
Mengele 530		
Vicon MP 800 M.F.5.		
Hesston 4700, 4750, 4860		
Hesston 4600/4820 (in pairs)		
Krone Big Pack 80/80		
Claas Quadrant 1100 (in pairs)		
Greenland 8080		
John Deere 680		
Bale Sizes: "Round Bales"	...	1.20m Bales Max 800kg
Film (Width of Roll)	...	750mm

\* The speed of rotation can be varied to suit various conditions but on no account should it exceed 25 r.p.m. (Speeds in excess of 25 r.p.m. will void warranty).

## PRE DELIVERY INSTRUCTIONS

**IMPORTANT:** DO NOT ATTEMPT TO OPERATE UNTIL THE FOLLOWING INSTRUCTIONS ARE PERFORMED OTHERWISE SERIOUS DAMAGE COULD BE CAUSED.

### 1. MACHINE ASSEMBLY

For ease of transportation some items are removed from their positions and stored elsewhere on the machine. The control box, film dispenser and cut and start unit are stored under the bale belt. Also stored under belt on remote control machines are the infra red receiver and sender units and warning beacon. The film mast is attached to the front of the machine. On round bale machines only, the top rollers c/w mounting brackets and the plastic end rollers are mounted on temporary brackets beside the bale belt. Road wheels, bale lift arm and bale ramp are transported separately. Remove the above items and assemble as detailed in parts list section of this manual taking particular note of the following points.

#### (i) DISPENSER MAST

Insert lift mast into socket towards front of machine. Ensure film pull down ram is faced towards the machine. Attach the pull down arm hydraulic ram. Attach the film dispenser to the mast ensuring that the end marked top is faced up. On remote control machines attach the infra-red receiver and warning beacon to top of mast. The film mast height is adjustable. Its height is dependant on bale size and type and is set in the field. It should be set so that centre line of film is in line with centre of bale. See Fig. 1

#### (ii) CUT & START

Attach Cut & Start unit to mounting frame on the left hand side of the machine. It is possible to move the unit along the mounting and fix it to any of three holes. On all round bale wrapping machines the unit is fixed to the centre hole on the mounting frame. Connect electrical supply to unit ensuring that wiring is secure. The cable is stored on the turntable frame near the Cut & Start mounting.

#### (iii) BALE LIFT ARM

Assemble bale lift arm and attach to mounting points on right hand side of main chassis. Attach hydraulic ram to lift arm; grease pivot pins.

#### (iv) TOP ROLLERS AND PLASTIC END ROLLERS

Place plastic end rollers in sockets on the back and front of the turntable. On round bale machines only, attach top rollers and mounting brackets to each side of the machine.

#### (v) ROAD WHEELS (trailed machines only)

Attach road wheels ensuring that nuts are tight and tyre pressure is 50 p.s.i.

#### (vi) BALE RAMP OR MAT

Attach bale ramp or mat to rear of chassis. Note Round bale trailed models have bale ramps with option hydraulic bale ramp. Linkage mounted machines have bale mats. A standard 1050 trailed models have hydraulic bale ramps.

SEE SEPERATE INSTRUCTION FOR FITTING HYDRAULIC BALE RAMP.

### CHECKS TO BE PERFORMED

1. Check that all bolts and nuts are tight.
2. That all lubrication points are greased.
3. Check that all guards are in place.
4. Check all operating and safety stickers are in place.

## 2. OPERATIONAL TEST

When all above assembly and checks have been carried out the operation of the machine should be checked as follows:

**NOTE: IF YOU ARE NOT TOTALLY FAMILIAR WITH THE OPERATION OF THE TANCO CONTROL SYSTEM READ THIS MANUAL IN FULL BEFORE PROCEEDING WITH OPERATIONAL TEST.**

1. Attach machine to tractor.
2. Connect hydraulic hoses to D/A service on tractor.
3. Fit controller box inside cab.
4. Connect control box to machine and connect power cable direct to tractor battery. It is important that the leads are connected with the correct polarity.
5. Fit cable control actuator socket to convenient position in cab and locate actuators in socket.
6. Lock hydraulic lever in tractor so that oil is flowing through system.
7. Check function by operating control levers.
  - (a) Lift arm up and lift arm down. NOTE ensure lift arm is down before moving to (b).
  - (b) Turntable rotation forward and reverse.
  - (c) Tip up and down checking hoses are o.k.
8. Switch controller on.
9. Switch controller to manual operating mode by operating toggle switch.
10. Check Cut & Start plunger out and in.
11. Switch machine to AUTO mode then run through the wapping cycle. See operating instruction section of this manual on how the machine should perform, and if any function fails to operate correctly consult fault finding section of the operators manual.

## 3. CUSTOMER CHECKS

Before despatching consult customer on the following points:

1. That the machine model suits his requirements.
2. If machine is to be operated on a tractor with a closed centre hydraulic system then a closed centre valve is required, see separate instructions.
3. That the tow hitch type is compatible with the tractor. Three different hitch types are available.

### INSTRUCTION FOR FITTING HYDRAULIC BALE RAMP.

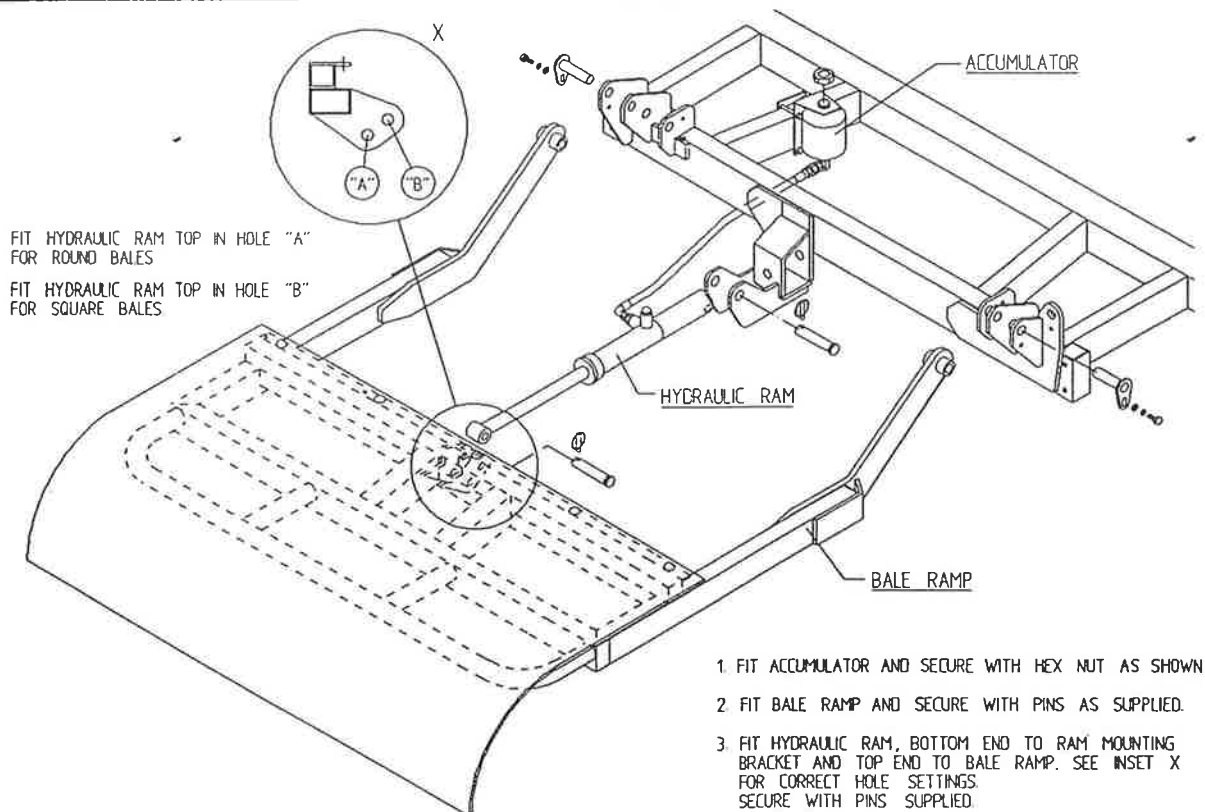

## TRANSPORT INSTRUCTIONS

1. Never use straps around the machine when lifting. Use only the following lifting points:- Tow hitch and two sockets on each side of main frame at rear for trailed models. 3pt. Linkage frame and two sockets on each side of main frame at rear for 3 pt. Linkage Model.
2. When the machine is towed on the road the Lifting Arm (if fitted) must be in the fully raised position, the safety prop fitted and the axle returned to narrowest position.
3. Raise the Parking Jack on trailed models before moving machine.

## MACHINE IDENTIFICATION

The Serial Number plate is located on main frame forward of offside wheel on trailed models and on 3pt. Linkage frame for 3pt. Linkage model.

Always refer to this number when ordering parts. The Spare parts catalogue number and description should be used. The reference numbers are used to help identifying the spare part.

For your records write serial number here.

SERIAL NO. \_\_\_\_\_

## PREPARATION OF A NEW MACHINE

1. Check height of film mast to ensure that centre line of film spool is level with the centre line of the bale on the turntable. This will alter with different bale diameters. If this alignment is not correct more film than necessary will be used. See fig 1.
2. When connected to John Deere\* tractor the value must be converted to closed centre.

## HYDRAULIC CONNECTIONS

Connect the feed and return hoses from the Autowrap valve to the tractors double acting facility.

NOTE: The return hose is fitted with a non-return valve to protect the Autowrap from damage in the event of incorrect connection to tractor hydraulics.

NOTE: To ensure maximum efficiency and length of lift of hydraulic components this machine requires a clean supply of hydraulic oil.  
IT IS RECOMMENDED THAT THE TRACTOR HYDRAULIC FILTER ELEMENT TO BE REPLACED AND THEREAFTER MAINTAINED IN ACCORDANCE WITH THE MANUFACTURERS RECOMMENDATIONS.

TANCO AUTOWRAP 1060 A MODELS C/W "TWIN-PAK" LOADING ARM  
 JUNCTION BOX AND CONTROLLER FOR 5 BANK VALVE

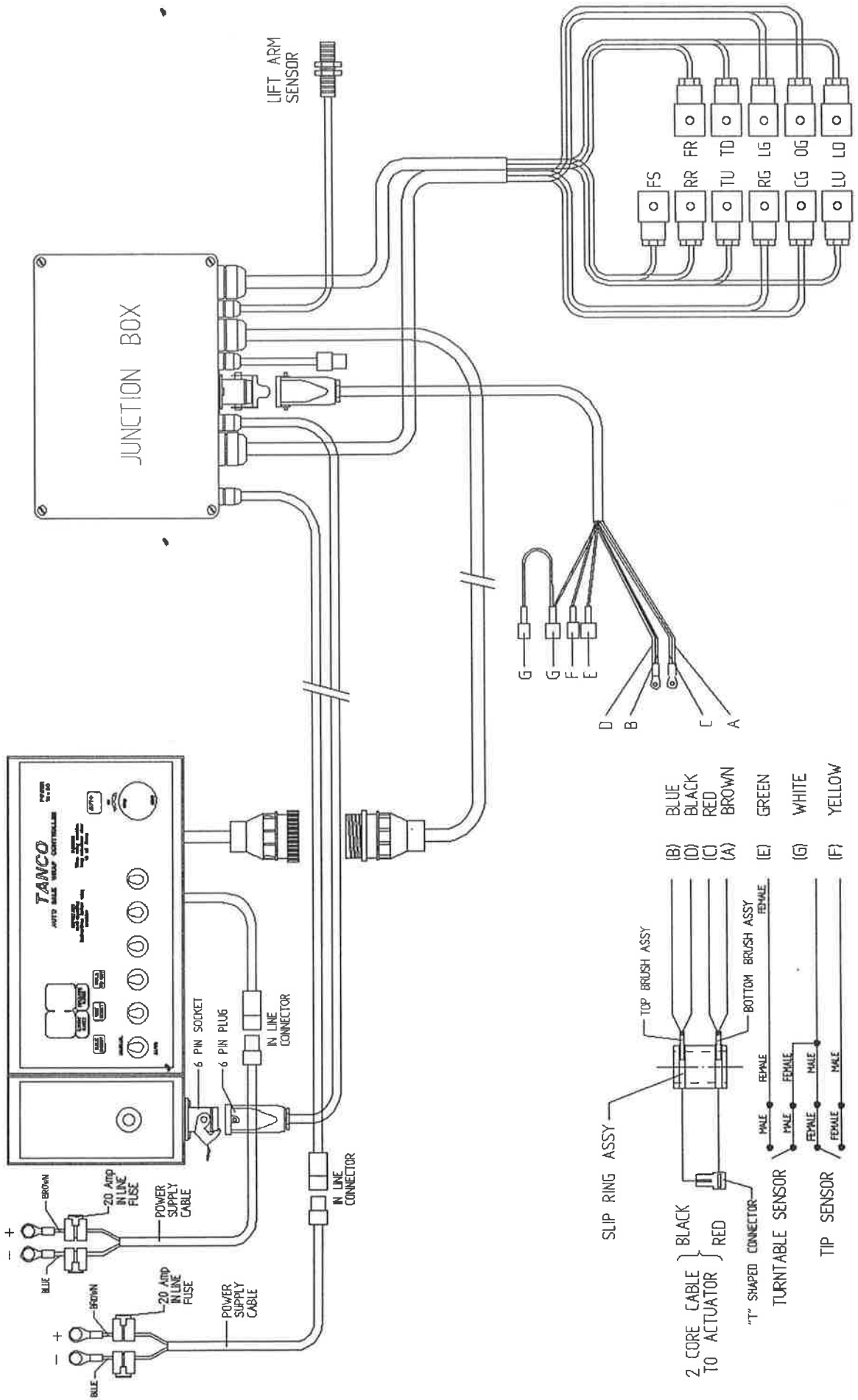

## AUTOMATIC BALE WRAP CONTROLLER (issue 110 onwards)

The control unit on the 1996 Autowrap allows full automated control of the bale wrapping sequence. The control unit is pre-programmed to automatically wrap the bale to the required number of rotations. Once complete, the turntable stops in the correct position to allow the film to be cut and held. Incorporated is also an inching override facility on the control unit to move the turntable, left or right, to ensure that the film is properly gathered. Once the turntable is lowered it rotates automatically back through 90 degrees to facilitate loading the next bale. For reasons of safety loading and tipping off of the bale is operator controlled using switches on the control unit.

The programming of the Automatic Bale Wrap Controller is easily done by following the steps outlined below.

Once the unit is switched on, the number of required turntable rotations appears on the right hand display. To change this press and hold the "Hold to Set" button, see fig 7., then press the "Set/Reset" button. The first digit of the number will then blink and count from 0-9. Release the "Set/Reset" button at the required number. By pressing the "Set/Reset" again the second digit can be changed.

The monitor counts the number of bales per batch and the cumulative total. To see these, press the "bale count" button. The first number to appear is the batch total. If the button is held down for 10 seconds, a line will appear on the display, followed by the cumulative number wrapped. The batch count can be reset to 0 by holding the "Bale Count" button down and pressing the "Set/Reset" once. The cumulative total cannot be returned to zero.

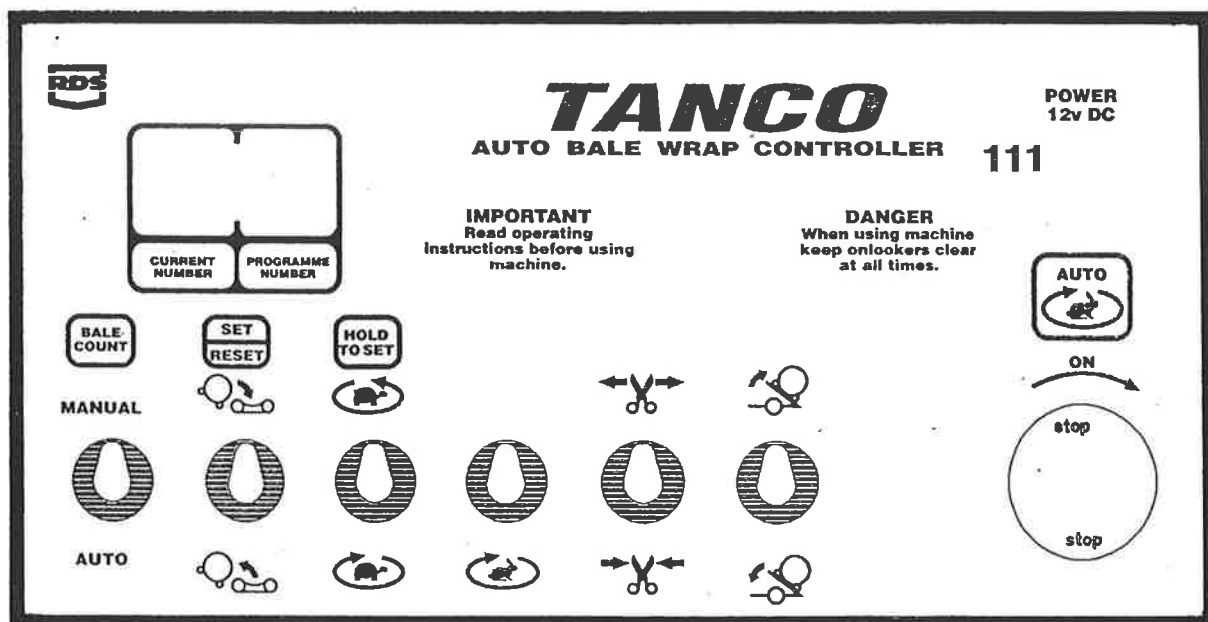
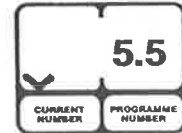

Fig. 7

## OPERATOR ACCESSIBLE MONITOR PROGRAMMES

The Auto Bale Wrap Controller displays a total of 7 programmes. To access the programming mode, turn the power off by pressing the red button, then press and hold the 'hold to set' key and turn the power on, by rotating the red button. Now you have accessed to the programming mode. A chevron 'V' will appear in the left side of the left display - this indicates the first function. By pressing the 'hold to set' key the next programme is accessed and so on. The chevron 'V' will move across the display indicating each of the 7 functions. The functions and settings are as follows.

Programme 1: Park Position  
Display Reading: 5.5 Seconds



Function: This is the time required for the 'Cut and Start' Actuator to return from the 'Open' position to the 'Park' position (See Diagram).

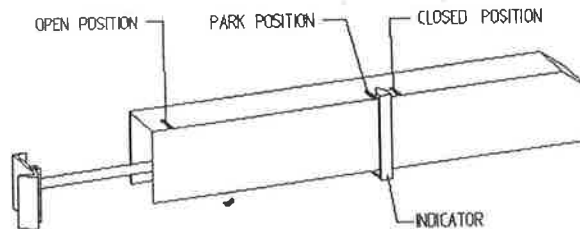

Due to varied output from tractor batteries, this reading may have to be altered to ensure that the indicator arm stops at the 'park' position.

- (i) If the indicator arm passes the 'park' position, then reduce the value by 0.1 sec. Repeat this until correct.
- (ii) If the indicator arm does not reach the 'park' position, then increase the value by 0.1 seconds until corrected.

Programme 2: Tip up.  
Display reading: 4.0

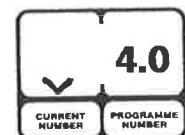

Function: This controls the time for which the tipping ram extends out after the 'Cut and Start' closes. **Note:** This value requires to be altered only when the setting of the rear magnet that impulses the tip sensor is changed.

- (i) If the magnet is adjusted upwards then this value will have to be increased.
- (ii) If the magnet is adjusted downwards then this value is decreased. Adjustment is in 0.5 second increments.

Programme 3: Tip up to tip down delay  
Display reading: 0.5



Function: Duration in seconds that the tipping ram remains fully extended between tip up and tip down.

Programme 4: Tip down.  
Display reading: 4.8



Function: This controls the time required for the turntable to return to the horizontal position. **Note**: This value should be increased if the film pull down arm does not retract fully. Adjust in 0.1 increments.

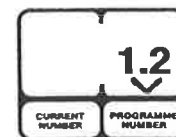

Programme 5: Duration of slow rotation at end of wrapping cycle.  
Display Reading: 1.2

Function: Shows time that elapses in seconds after turntable magnet passes rotate sensor on last rotation before turntable changes to slow mode. **Note**: This value need only be altered as follows.

- (i) To increase duration of slow rotation at end of wrapping cycle, reduce this value in 0.1 increments.
- (ii) To reduce duration of slow rotation at end of wrapping cycle, increase this value in 0.1 increments.

**Programme 6:** Machine Operation.

There are four separate settings for this programme depending on the model of machine being used. Two of the settings apply to remote control models and two to non remote models.

**Remote control mode with no 90 degrees reverse function**  
= Symbol **r**.

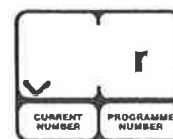

**Remote control mode with 90 degrees reverse function**  
= Symbol **R**.

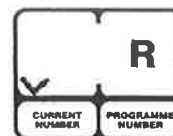

**Non remote control mode with no 90 degrees reverse**  
= Symbol **o**.

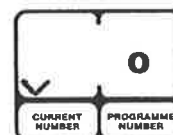

**Non remote control mode with 90 degrees reverse**  
= Symbol **O**.

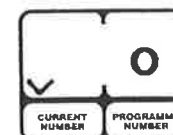

**Programme 7:** Tractor hydraulics.

Designed to convert the hydraulic system to open or closed centre hydraulics to suit tractor.

Closed centre = Symbol **J**

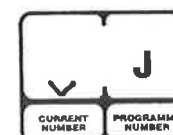

Open centre = Symbol **n**.

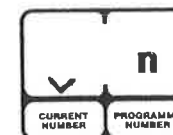

**NOTE:** An additional valve is required for operating in the **J** mode.

## MODE OF OPERATION

### Automatic Mode: with switch in "Auto" Position.

1. Ensure turntable is in correct position to accept bale and that film is gripped by the "Cut and Start".
2. Lower bale lift arm, drive alongside, pick up the bale and raise the lift arm.
3. Allow the bale to roll gently onto the turntable so that it is central between the end rollers.
4. Lower the arm clear of the turntable and press the "Auto" (Start) button commence wrapping. NOTE: The table must be in the correct position before the "Auto" (Start) button is pressed. If not the table may stop in the wrong position at the end of wrapping.
5. With the controller in Automatic Mode the turntable will start off for half of one rotation in "Slow Mode" before changing to "Fast Mode". During the final rotation it will change to "Slow Mode" and stop in the correct position so that the film is lined up above the open "Cut and Start".  
NOTE: The turntable can be moved to left or right to align the "Cut and Start" by using the slow rotate switch on the controller or the buttons on the remote control unit.
6. On the third rotation of the wrap cycle the "Cut and Start" will open automatically. An indicator on the outside panel shows what stage the "Cut and Start" is at. On the ninth revolution the actuator will return to the "Park Position" indicating that the "Cut and Start" is ready to close. Note: The indicator must be at the "Park Position" in either Manual or Automatic Mode before the "Cut and Start" will close.
7. When in a safe position to do so, press the "Tip Up" button, the turntable will tip upwards gathering the film on the "Cut and Start" plunger whilst the pull down arm reduces the film to a rope which is cut as the "Cut and Start" snaps shut, releasing the bale but gripping the film end in readiness for the next bale.
8. The tip off sequence is automatic and once the turntable lowers it will reverse and stop in position to facilitate loading, if programmed to do so.

### Manual Mode: with switch in "Manual" Position

1. Load the bale as outlined above.
2. Using the slow rotation switch, start the wrapping cycle.
3. After half of a rotation, switch to the fast wrapping mode by pressing the appropriate switch.
4. During the wrapping extend the "Cut and Start" out to the end mark and return the indicator to the "Park Position".
5. At the end of the wrap cycle line up the "Cut and Start" with the film.
6. When safe to do so, tip up the turntable until all the film is gathered on the "Cut and Start". Operate switch to close position, the "Cut and Start" will snap shut cutting the film. Continue tipping until the bale rolls off then lower the turntable.
7. Position the turntable to load the next bale.

## Operating Instructions

1. Fit roll of film and thread through the Dispenser roller assembly by following the instruction label on the film mast.
2. Set the bale wrap indicator to the correct setting for the size of bale being wrapped and the width of film being used. See Table 1 for list of some recommended settings.
3. Power down Lift Arm until wheel is clear of ground and adjust wheel outward to appropriate setting for bale weight.
4. Adjust tractor engine speed to give turntable speed of 16 - 25 r.p.m.  
**NOTE:** Speeds in excess of 25 r.p.m. will void Warranty.
5. Position turntable with cut and start unit facing front of machine.
6. Attach film tag end to gripper section of cut and start unit.
7. Rotate turntable anticlockwise through 90 degrees and stop turntable with cut and start unit opposite to lift arm.
8. Locate bale on lift arm, then raise lift arm and gently roll bale onto turntable. Lower arm.
9. Start wrapping, turntable rotating clockwise. Film tension is automatically set so that width of film applied to the bale stays at a constant width of 600mm for 750mm wide film roll.
10. Continue wrapping until signal from bale indicator sounds (required number of revolutions has been reached). Then stop with cut and start facing towards front of machine and film aligned with gripper section of cut and start unit.
11. Tip bale from machine. When the machine is almost fully tipped the cut and start unit grips and cuts the film and the bale is then unloaded down the bale ramp.
12. Lower the turntable and rotate anticlockwise through 90 degrees and stop with cut and start unit opposite to lift arm.
13. Repeat operations 7 - 12 as required.
14. Ensure that 220mm dia idler roller mounting bearing is attached to correct set of mounting holes in mounting bracket to wrap square/rectangular or round bales. See fig A. below.

**NOTE:** The film end need only be attached at the start of a roll, after that the sequence is automatic.

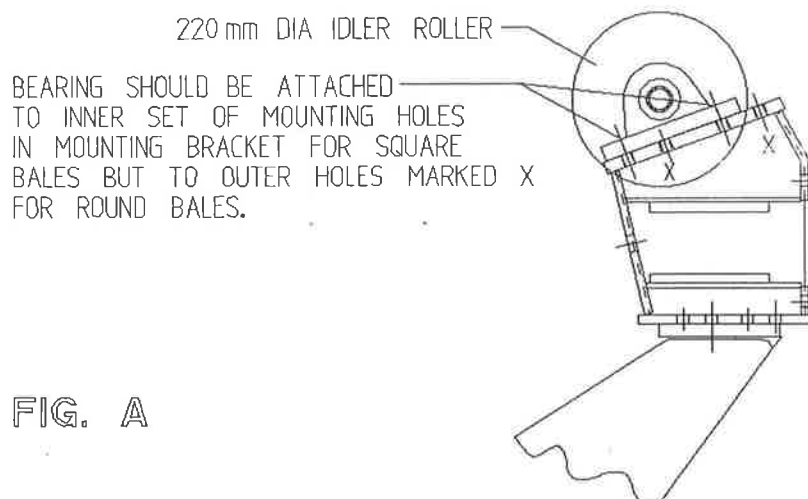

**WARNING: LIFT ARM**

1. The Lift Arm on the trailed machine is designed to pick up and deposit bales onto the turntable prior to wrapping and to raise the machine while empty, to facilitate adjustment of sliding axle. It is not intended to be used for transporting bales over distances or for use as a stabiliser whilst wrapping.

Therefore any use of the lift arm outside its primary function will be deemed to be abuse and will void all warranty.

2. Before raising loading arm ensure that turntable is in correct position for loading bales so that loading arm will not foul it.

Failure to observe this warning will lead to failure of turntable centre bearing and/or turntable 4" support wheels which will not be covered by warranty.

**OPERATING INSTRUCTIONS  
"TWIN-PAK" LOADING ARM**

The "Twin-Pak" loading arm will lift and load bales of 80cm x 47/50 in pairs, one on top of the other.

If necessary the "Twin-Pak" arm is capable of stacking the bales in pairs itself, before loading on to the wrapper, but it is more efficient if used in conjunction with a bale accumulator.

When handling square or rectangular bales the hydraulic cylinder should be positioned in hole "b" see Fig below.  
When handling round bales the hydraulic cylinder will have to be positioned in hole "A".

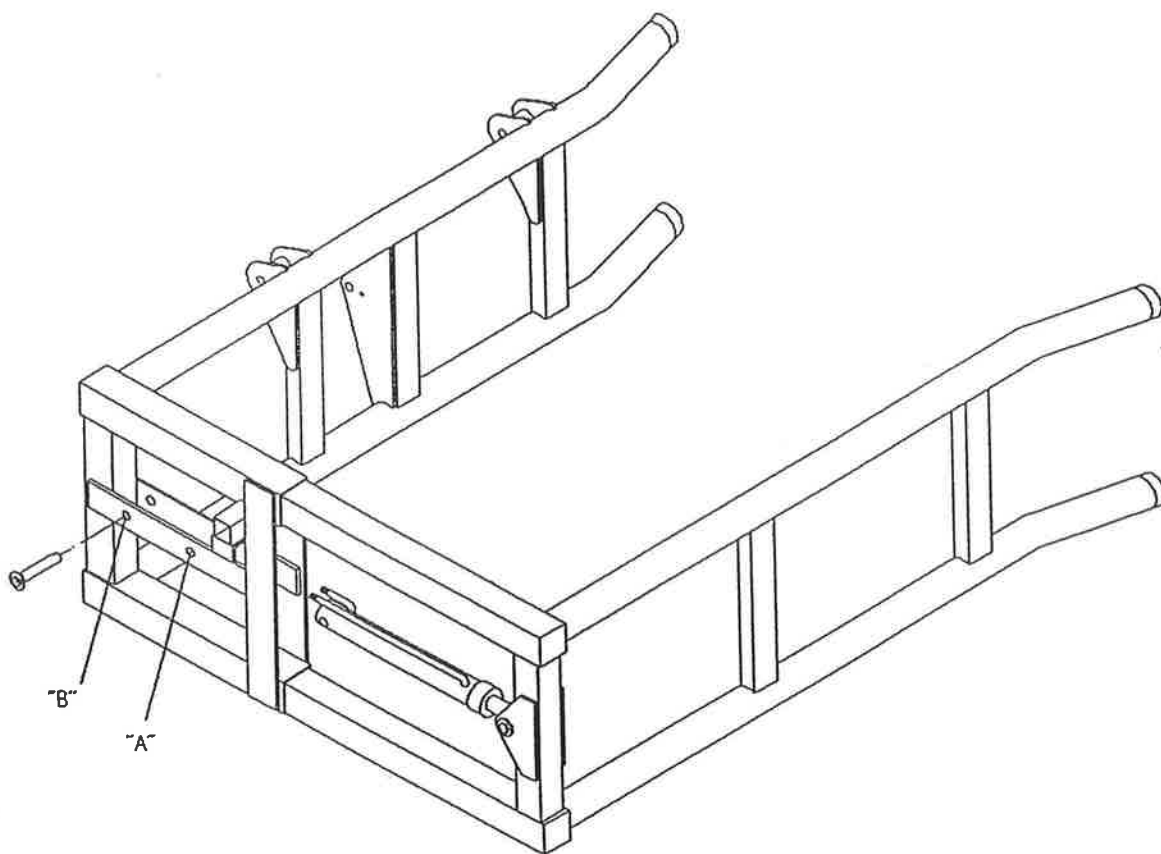

# AUTOWRAP 1060 "TWIN-PAK" LOADING SEQUENCE

FIG 10

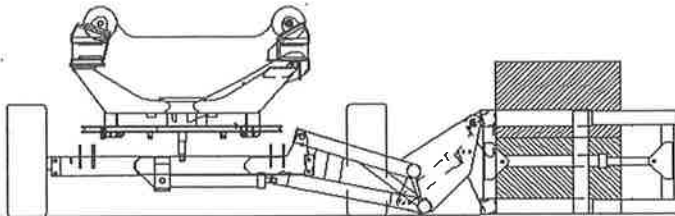

FIG. 10  
WITH THE MAIN LOADING ARM DROPPED DOWN SO THAT IT REST LIGHTLY ON ITS SKIDS, WITH OUTER ARM EXTENDED OUT FULLY. DRIVE FORWARD WITH INNER ARM ALONGSIDE THE BALES UNTIL THE BALES COME IN CONTACT WITH BALE STOP.

FIG 11

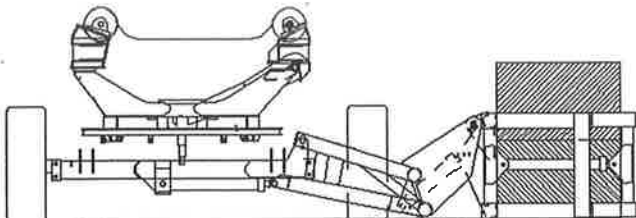

FIG. 11  
CLOSE OUTER ARM TO GRIP BALES SECURELY.

FIG 12

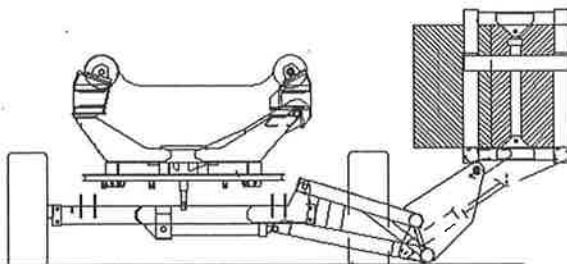

FIG. 12  
RAISE GRAB SECTION FULLY AS SHOWN.

FIG 13

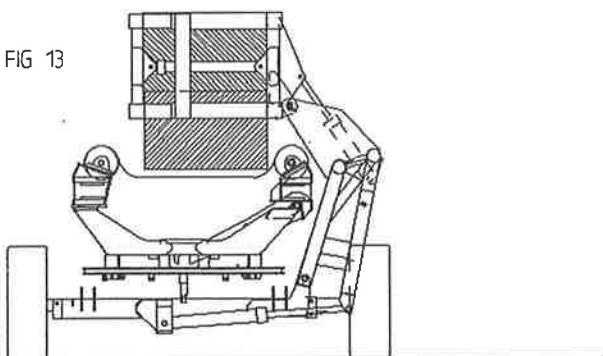

FIG. 13  
RAISE LIFT ARM TO POSITION  
BALES ON TURNTABLE.  
OPEN OUTER ARM TO RELEASE BALES ONTO BELT.

**WARNING:**

1. THIS LOADING ARM IS DESIGNED TO LOAD BALES WHILE THE WRAPPER IS STATIONARY AND NOT WHILE ON THE MOVE. FAILURE TO OBSERVE THIS WILL LEAD TO PREMATURE BREAK UP WHICH WILL NOT BE COVERED BY WARRANTY.
2. BEFORE RAISING LOADING ARM ENSURE THAT TURNTABLE IS IN CORRECT POSITION FOR LOADING BALES SO THAT LOADING ARM WILL NOT FOUL IT. FAILURE TO OBSERVE THIS WARNING WILL LEAD TO FAILURE OF TURNTABLE CENTRE BEARING, WHICH WILL NOT BE COVERED BY WARRANTY.

FILE NAME: 94025

### **FILM OVERLAP SYSTEM.**

The Autowrap is fitted as standard with the 2 x 2 x 50% film overlap system. This is achieved by means of a chain drive which ensures that the correct number of film layers are applied to the bale after a specific number of revolutions of the turntable. The number of revolutions required to wrap a bale depends on width of film being used and bale size - See table below.

For silage bales we recommend the application of a minimum of four layers of film.

<b>Bale Size</b>	<b>Width of Film Roll</b>	<b>Bale Indicator Setting (Revs)</b>
Square and Rectangular	750mm	18

### **IMPORTANT**

The above recommendations are only offered as a guide to correct wrapping of silage bales and the manufacturer accept no responsibility for variations that may arise and the consequence of same. They are based upon turntable speeds of up to 25 r.p.m., and a minimum film width of 600mm applied to end bale when using 750mm wide film roll

**It is the responsibility of the operator to ensure the correct number of wraps are applied, as variances can occur with fluctuations in speed of rotation, film quality and tensioning, shape and density of bale etc.**

## SERVICE AND MAINTENANCE

1. All nuts and bolts should be tightened after some hours in use and thereafter regularly.
2. Wheel pressure should be normally kept at 42 psi depending on bale weight and field conditions.
3. Inspect moving parts for wear on daily basis.
4. Lubrication.

Drive chain & sprocket	-	grease every 24 hours.
End rollers	-	grease every 24 hours.
Main rollers	-	grease every 24 hours.
Hinge pins on Lift arm	-	grease every 24 hours.
Hinge pins on main tip frame	-	grease every 24 hours.
Hydraulic rams	-	grease every 24 hours.
Wheel bearings	-	grease every 24 hours.
Film reel assy.	-	grease every 24 hours.
Dispenser gearboxes	-	grease sparingly each month.
Main spindle	-	grease every 4000-5000 bales.
Gearbox oil level	-	Check every 4000-5000 bales.
5. Adjustments

Turntable Drive chain	:	Adjust after first days work then check/adjust every 50 hours. See Fig. 8.
Gearbox Drive chain	:	Adjust after first days work then check/adjust every 50 hours. See Fig 2.
Roller Drive chain	:	Adjust after first days work then check/adjust every 50 hours See Fig 3.
Main Bale Belt	:	See belt tracking instuction.
6. Film Dispenser

Fit with marked gearbox at top.  
Apply one shot of EPO type Grease  
Wash rollers often to avoid build up of Tack from film using petrol.  
Follow Film threading diagram. See Fig 1.
7. Film Adjustment

Centre of film roll must be in line with centre of bale and film mast should be vertical.

8. Shear Pins

There are two shear pins fitted to sprocket assembly on drive roller see fig 5. If the pins shear, remove the broken pins re-align holes and fit two replacement spiral pins, 6mm dia x 20mm long, Din 7343. There are two spare shear pins attached to inside of chain guard.

**NOTE:** If shear pins are replaced with other than specified above all warranty is null and void.

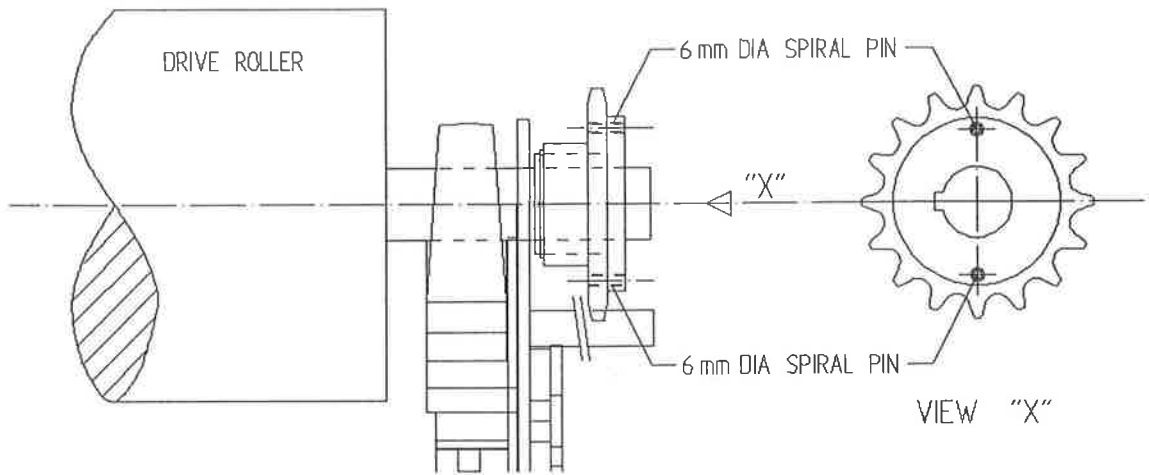
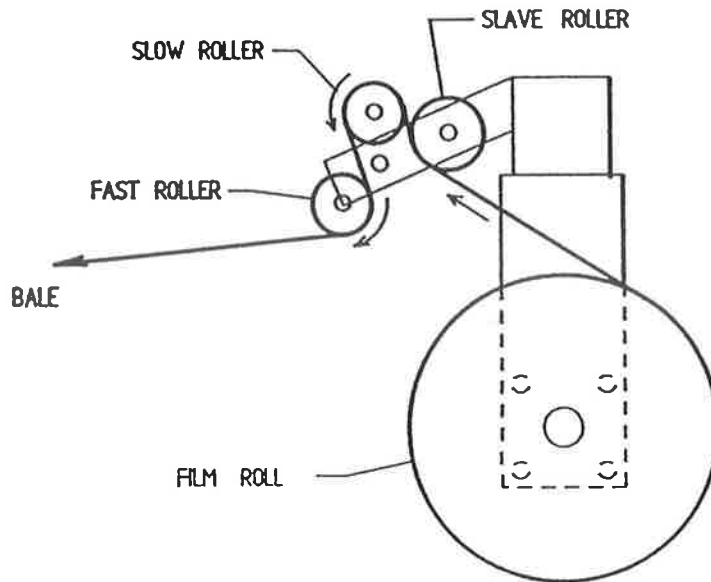

FIG. 5

**SERVICE AND MAINTENANCE (CNT.)**  
**HYDRAULIC FILTER**

1. Before connecting Autowrap to tractor, change oil in tractor hydraulic system and replace hydraulic filter.
2. After 25 hours max. it will be necessary to replace the element in Autowrap filter.
3. For maintenance purposes it is necessary to change the element after 200 working hours.
4. The element cannot be just cleaned and put back into the filter.

# TANCO AUTOWRAP FILM THREADING DIAGRAM



## FILM ADJUSTMENT

CENTRE OF FILM ROLL MUST BE IN LINE WITH CENTRE OF BALE AND FILM MAST SHOULD BE VERTICAL.

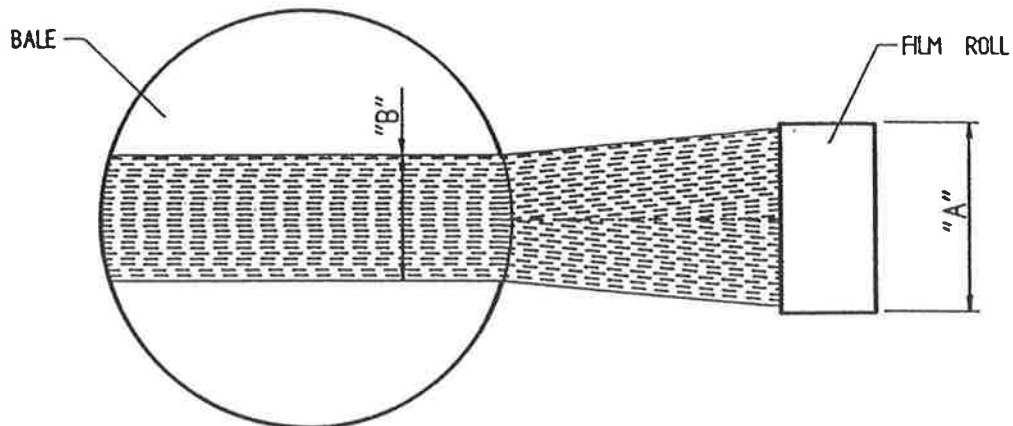

FILM ROLL WIDTH "A"	FILM WIDTH ON END OF BALE "B"
500 mm	400 mm
750 mm	600 mm

Fig. 1

FILE NAME W060-LA21

# TANCO AUTOWRAP CONSTANT INDEXING GEARBOX CHAIN DRIVE TENSIONING SYSTEM (1996)

- CHAIN TENSIONING PROCEDURE
1. LOOSEN M10 BOLT SECURING CHAIN TENSIONER.
  2. TENSION CHAIN BY ADJUSTING TENSIONER USING SPANNER IN DIRECTION OF ARROW "X" UNTIL SETTING OF 15-20" IS REACHED.
  3. RE-TIGHTEN M10 BOLT TO SECURE TENSIONER IN POSITION.

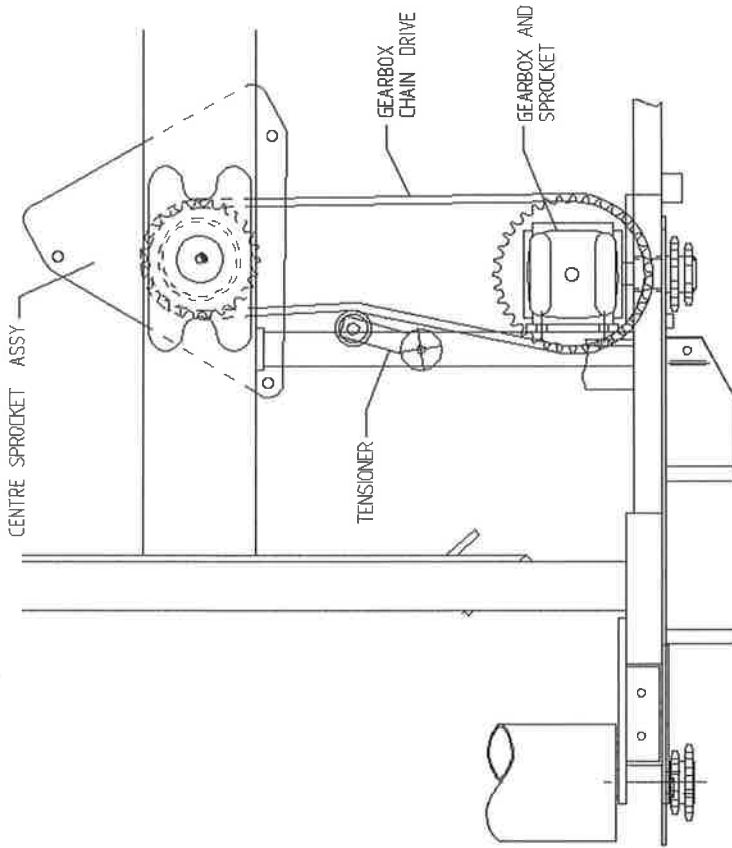
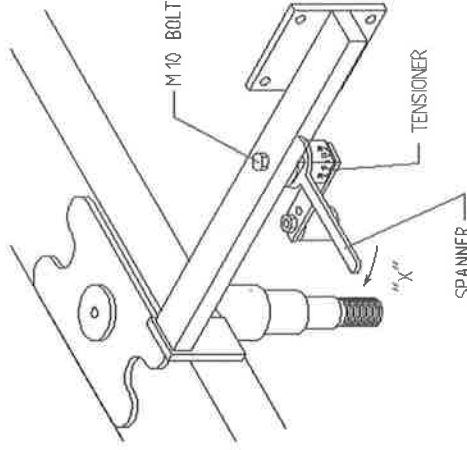

Fig. 2

- ## ROLLER CHAIN DRIVE TENSIONING SYSTEM
- CHAIN TENSIONING PROCEDURE
1. LOOSEN M10 BOLT SECURING CHAIN TENSIONER
  2. TENSION CHAIN BY MOVING CHAIN TENSIONER INWARDS IN SLOT
  3. RE-TIGHTEN M10 BOLT TO SECURE TENSIONER IN POSITION.

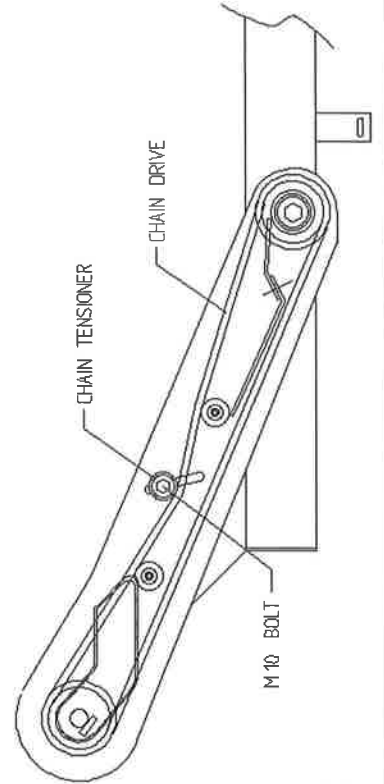
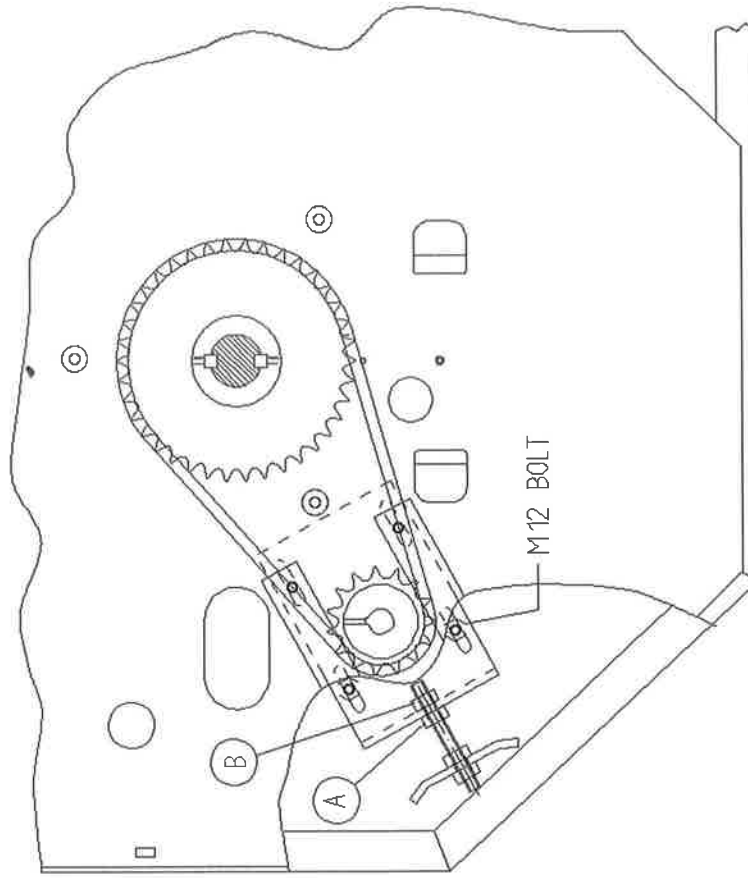

Fig. 3

# TANCO AUTOWRAP 1996 MODEL TURNTABLE CHAIN DRIVE TENSIONING SYSTEM



## TENSIONING PROCEDURE

1. TIP UP MACHINE AND SUPPORT WITH A PROP.
2. REMOVE CHAIN GUARD.
3. SLACKEN M12 CLAMPING BOLTS SLIGHTLY.
4. SLACKEN LOCKNUT A.
5. ADJUST NUT B UNTIL THERE IS 8 mm - 10 mm DEFLECTION ON CHAIN.

NOTE WARNING:  
DO NOT OVER TENSION CHAIN AS MOTOR WILL BE DAMAGED

6. TIGHTEN LOCKNUT A.
7. TIGHTEN M12 CLAMPING BOLTS.
8. REFIT CHAIN GUARD.

Fig. 8

TANCO AUTOWRAP 1060 MODELS  
BALE BELT TRACKING

This machine is fitted with a continuous belt which has a natural tendency to float due to variations in bale shape centrifugal forces etc. However if the following instructions are followed closely the final setting for tracking the belt can be arrived at over a maximum of two or three bales in the field. The ideal settings will ensure that the belt will always return to a central line

Prior to despatch from our works the belt is centralised on the machine and the belt adjuster and belt tracking rollers are adjusted to the settings on the drawing B.T.I attached.

The belt adjuster roller (item 1) is initially set slightly offset to the drive roller, see A & B. Its primary function is to control the sag in the belt so that the centre of the bale is high enough to ensure that it is fully wrapped correctly on the ends but may also require adjustment to control the belt on the drive roller (see belt tracking procedure below).

The belt tracking roller is purposely set out of line to the top roller, see C & D. Its functions to put tension on one side of the belt to counteract the tendency of the belt to move sideways. The bale will always try to move away from the chain drive side of the machine until it touches the plastic end roller at the other side, at which point the bale will attempt to move away from the bale and towards the chain drive side.

The degree of offset of the tracking roller (item 2) may need adjustment to control the belt on the idler roller.

BELT TRACKING PROCEDURE

1. Ensure the belt tracking roller is adjusted to the initial settings at C & D, (see drawing), and that the belt adjuster roller is adjusted to settings at A & B.
2. Load bale and rotate turntable for approx. 20 revolutions without film being applied and observe if belt moves.
3. If the belt moves more than 30mm out of line, observe which roller it moves on and in which direction it moves then adjust the appropriate roller inwards on the side the belt moves away from in 5mm increments until the belt stays relatively central.
4. Attach film and commence wrapping the bale manually whilst making adjustments as per 3 above.
5. Tip off bale then fresh bale and again wrap using manual controls. If adjustments have not been excessive on any one roller then the belt should now run central.
6. Load next bale and commence wrapping in auto mode whilst observing how the belt behaves. If the belt movement is less than 30mm on either roller do not adjust again but continue wrapping bales.

**NOTE:** The belt will always move because each bale is different, but provided it runs reasonably central it should not require any further adjustments.

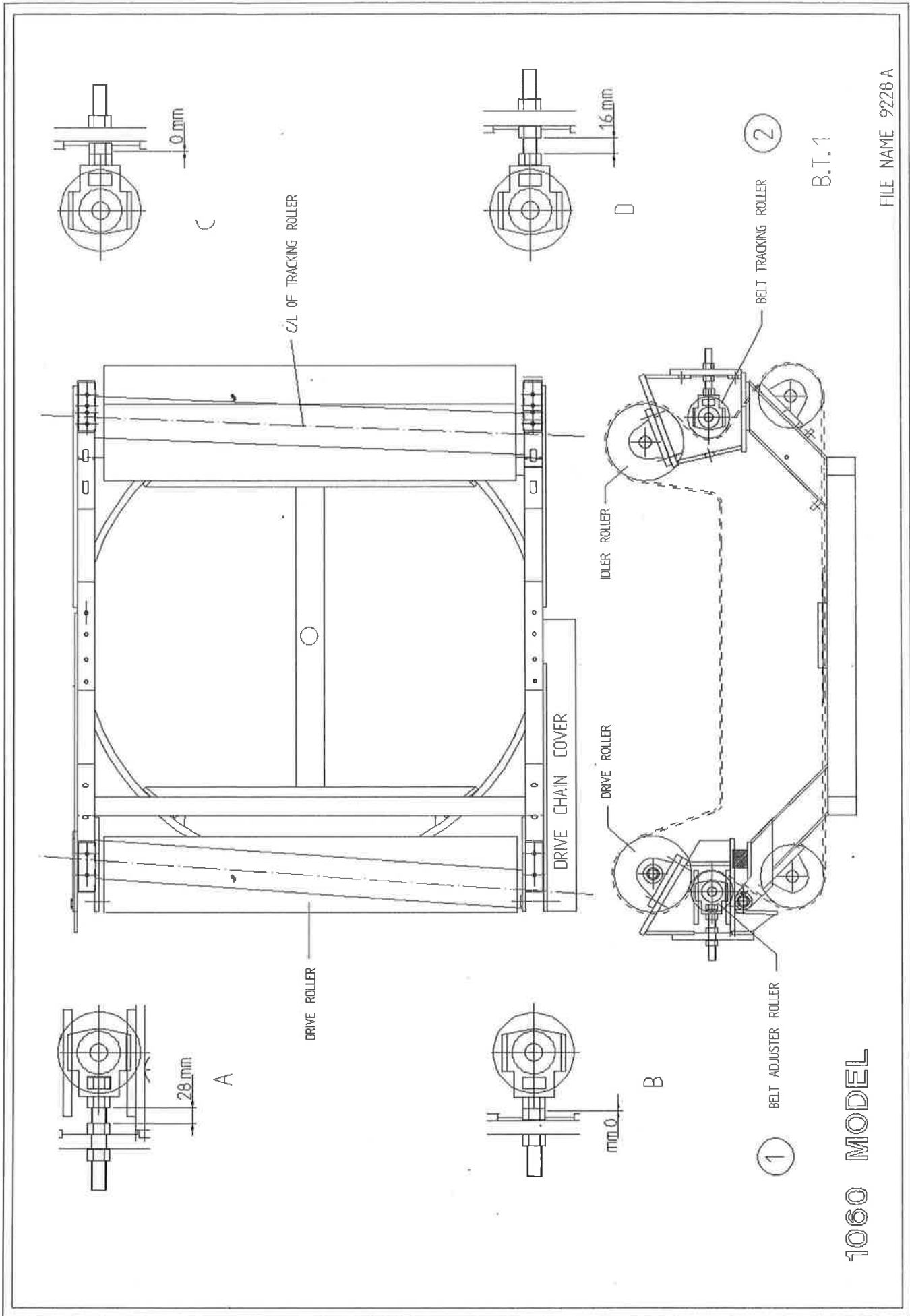

FILE NAME 9226 A

1060 MODEL

B.T.1

