

1120 Autowrap



OPERATOR'S handbook

TABLE OF CONTENTS

Chapter	Contents	Page
1	SAFETY DECALS	2
2	INTRODUCTION	3
3	TECHNICAL SPECIFICATIONS	6
4	SAFETY PRECAUTIONS	7
5	BALE WRAPPING	9
6	MACHINE SETUP	11
7	EH CONTROLLER INFORMATION	20
8	OPERATIONAL FEATURES	29
9	ELECTRO-HYDRAULICS	32
10	TROUBLESHOOTING	38
11	MAINTENANCE	41
12	GUARANTEE	43
13	DECLARATION OF CONFORMITY	44



Read Operators Manual
Prior to using machine

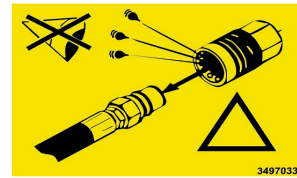

Warning, all hoses are
constantly under pressure

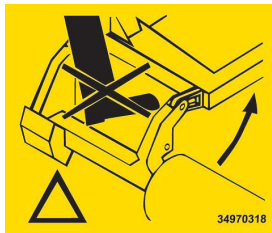

Warning, do not place your
feet between roller arms
and chassis

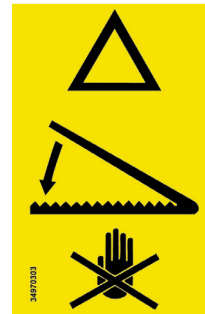

Danger keep hands
clear of sharp blades



Ensure all nuts & bolts have
been tightened prior to
operating the machine



Danger from rotating
Prestretcher



Danger stay at a safe distance
whilst machine is in operation

Tanco Autowrap Ltd congratulates you on your choice of the TANCO AUTOWRAP bale wrapping machine from the 1120 Model Range. We are certain you will be satisfied with the machine, and that you will have the pleasure of your investment for many years.

The TANCO AUTOWRAP bale wrapping machine has more features than any other bale wrapping machine available. The 1120 model can pick up the bale, wrap and stack them without the operator leaving the tractor cab; this is a patented system.

This machine is hydraulically driven by the tractor's hydraulic system and is controlled from the tractor cab by an automatic control unit. The machine can either be mounted to three point linkage, front mounted with quick-couplers to the tractors front loader or on a wheel loader. Then it's possible to stack the bales upon each other. The wrapped bale can be either dropped conventionally to the ground or with the fitting of an optional 'End Tip' the bale can be dropped on its end.

TANCO AUTOWRAP 1120 Range is designed to wrap bales of grass, hay or straw, with nominal diameter of 1.1 - 1.5m, and weights up to (1200kg).

This manual is meant to explain how TANCO AUTOWRAP 1120 is setup, attached to the tractor, used and how it works, and shall together with the spare part's list be a reference for maintenance and troubleshooting. So take good care of this book; it is a part of the machine.

Read carefully through this manual, and especially the safety instructions, before starting the machine. Follow the instructions thoroughly, if problems should occur, check the troubleshooting guide to try to establish the problem. Ask your dealer for advice before you attempt anything that may make the problem worse.

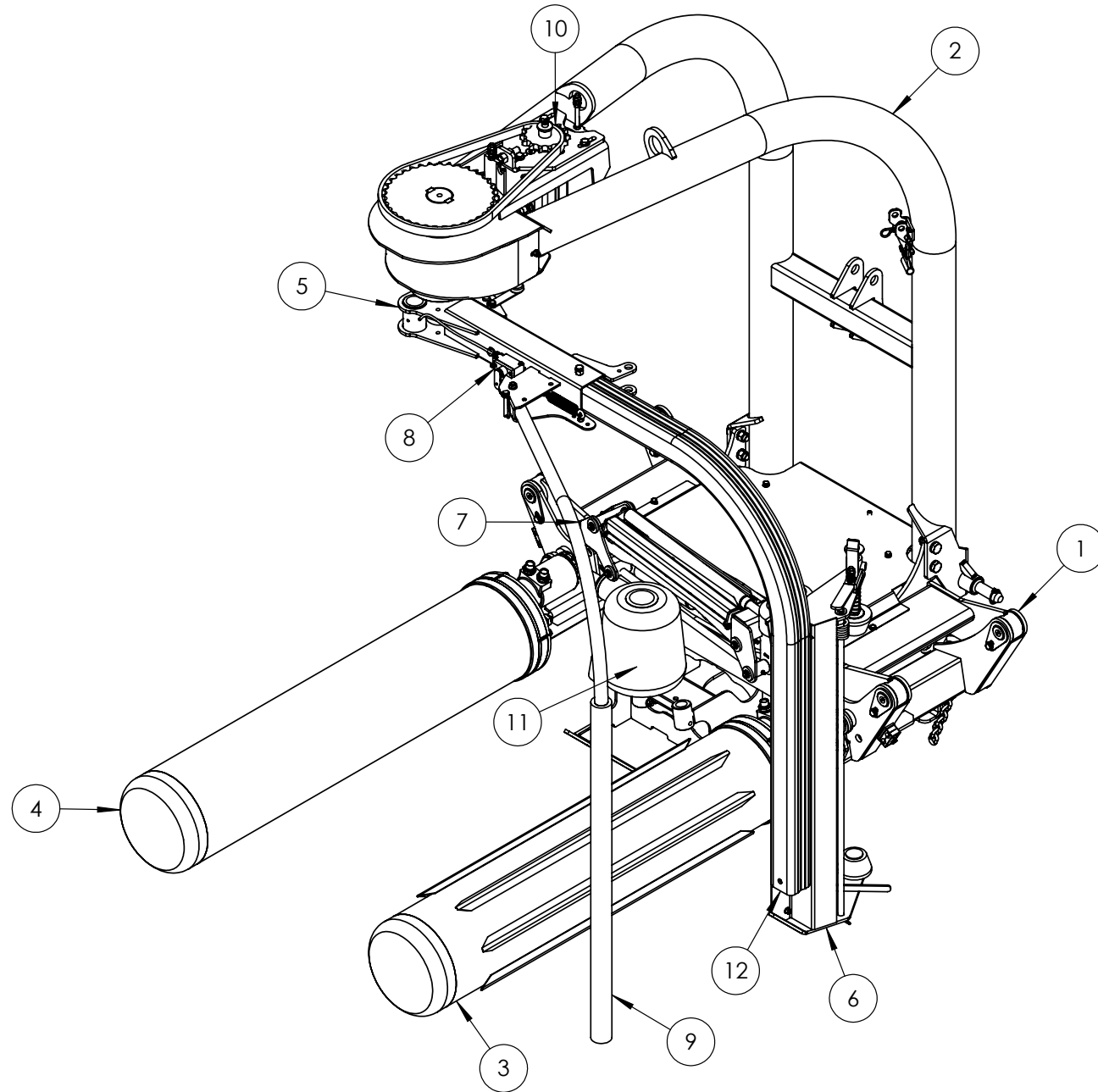

Item No.	Description
1	Main Frame
2	Tower Frame
3	Gripped Roller
4	Smooth Roller
5	Main Wrapping Arm
6	Main Dispenser Assembly
7	Cut & Tie Assembly
8	Safety Switch
9	Emergency Stop Arm
10	Wrap Arm Drive Motor
11	Support Roller
12	Dispenser Mounting Arm

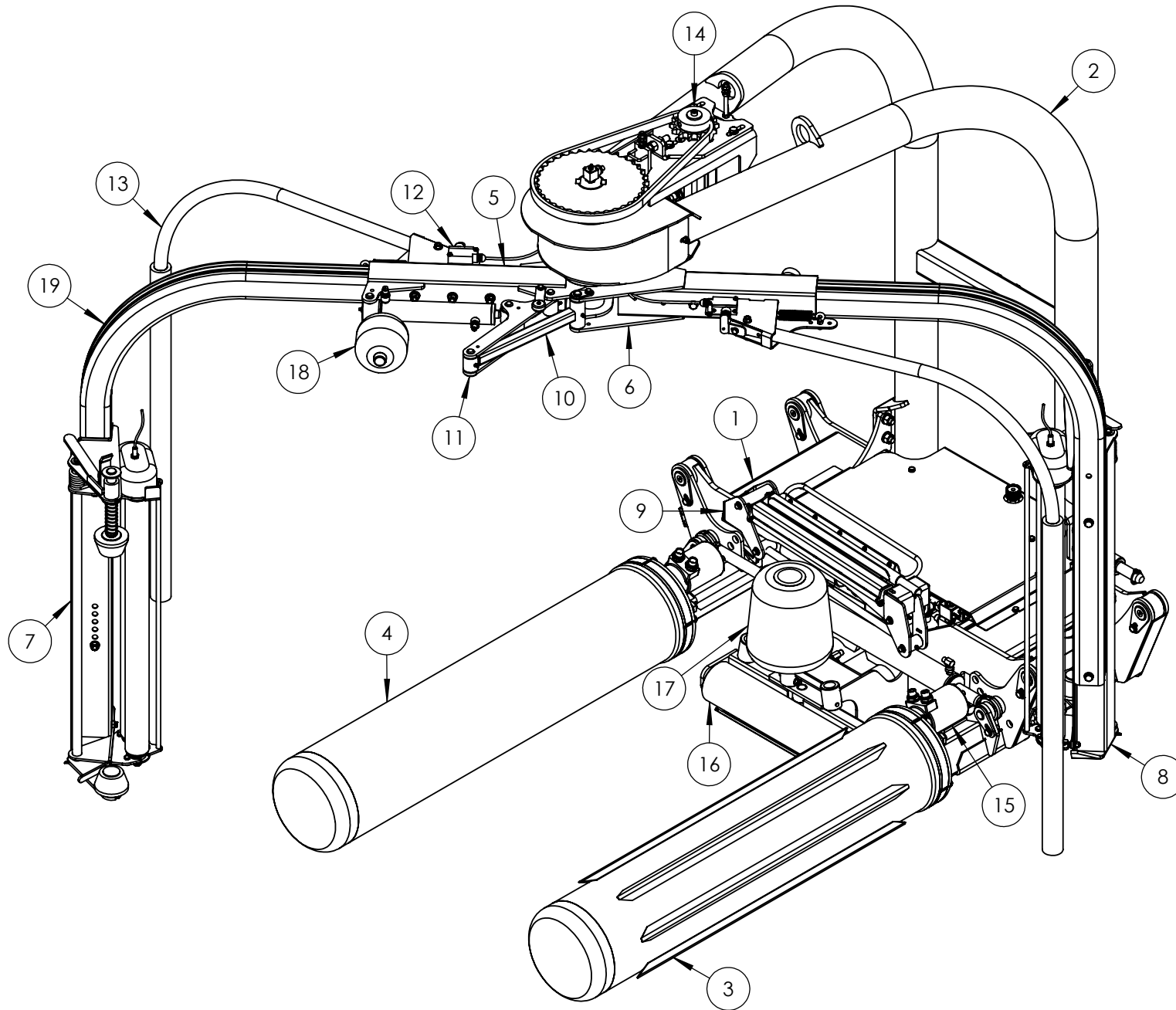

Item No.	Description
1	Main Frame
2	Tower Frame
3	Gripped Roller
4	Smooth Roller
5	Main Wrapping Arm
6	Slave Wrapping Arm
7	Main Dispenser Assembly
8	Slave Dispenser Assembly
9	Cut & Tie Assembly
10	Fixed Linakge
11	Arm Linkage
12	Safety Switch
13	Emergency Stop Arm
14	Wrap Arm Drive Motor
15	Roller Motor
16	End Tip Assembly
17	Support Roller
18	Arm Folding Ram
19	Dispenser Mounting Arm

Technical Specifications	1120 EH Autowrap
Height	2270mm
Width	1370mm / 2230mm
Length	2260mm
Weight	655 kg
Wrapping Arm Speed (Recomended)	28 R.P.M
Wrapping Arm Speed (max)	32 R.P.M.
Bale Diameter	1500mm
Bale Length	1000mm
Maximum Bale Weight	1200 kg
Capacity	35 Bales per hour (Apx.)
Pre-Stretcher(s)	1 x 750mm Width; 55 & 70% Stretch
Hydraulic Connection	Double + Single + Free Return
Oil Pressure	180 bar
Oil Amount (Max / Min)	50 lts/min / 25 lts/min)
Maximum Counter Pressure	10 bar
Eltecrical Connection	12 V DC

NB: Tanco Autowrap Ltd. reserves the right to modify the construction and/or technical specifications without warning and without rights to changes on already delivered products.



Tanco Autowrap Ltd does not take responsibility for damages that may occur to machine, persons or other equipment, because of the machine NOT being used as described in this manual, or because of the safety precautions NOT being followed.

Emergency Stop

The Tanco Autowrap 1120 Model is equipped with a so-called emergency stop on the wrapping arm. This device stops all functions momentarily, but is per definition not an emergency stop, because it does not shut down the inputs. But it has the same function, so we have decided to call it an emergency stop in this manual.

Safety Equipment

Before using the machine, make sure that all guards and covers are securely fitted. The machine must not be operated if a function does not work as described later in this manual.

Become Familiar with the Operations of the Machine

If you are unsure how to operate the machine properly, either use of or maintenance to your Tanco autowrap, please contact your Tanco autowrap dealer.

Adjustments / Maintenance

Turn off the tractor and discharge the oil pressure before performing any adjustment or maintenance on the machine. Remember that a well maintained machine is a safe machine.



IMPORTANT!

Always make sure nobody is in the hazard area of the wrapping arm when the machine is in-use.

The machine must not be operated by persons who do not know enough about how to safely operate the machine, or by persons under the age of 16 years.

Dangerous Areas

Tanco Autowrap Ltd. has given the safety to the operator the highest priority, but it is still impossible to secure oneself of every danger area on the machine. Therefore we have highlighted below some of the dangers that can occur when using the 1120 Tanco Autowrap Bale Wrapper.

- Impact of the Wrapping Arm

During the wrapping process the arm rotates with a speed of 30-32 revolutions per minute around the bale. On the arm is mounted a Film dispenser unit with a plastic roll. The speed on this can give a person serious injuries if one enters the working area of the wrapping arm. To reduce this danger we have mounted an emergency stop device on the wrapping arm; this stops all movement when something comes in the way of it. It is very important that this protection always works and that it should not under any circumstances be disconnected.

- Squeeze Danger Between the Main Frame & Wrapping Arm

As earlier explained, we have a wrapping arm with a Dispenser and a plastic roll. During every revolution the wrapping arm passes the main frame. Here there may occur a squeeze danger if a person stands too close to the main frame when the wrapping arm passes. The distance between the main frame and the wrapping arm is not large enough to give place for a person. Between the pre-stretcher and the bottom frame there can also be a squeeze danger.

- Squeeze Danger Between the Stationary Arm & Wrapping Arm

During the main wrapping process the wrapping arm moves around a stationary arm. Everytime the wrapping arm passes the stationary arm there is a squeeze danger that can be dangerous for the fingers. The distance between the stationary and the wrapping arm is between 25-40 mm. (See Fig. 4.1).

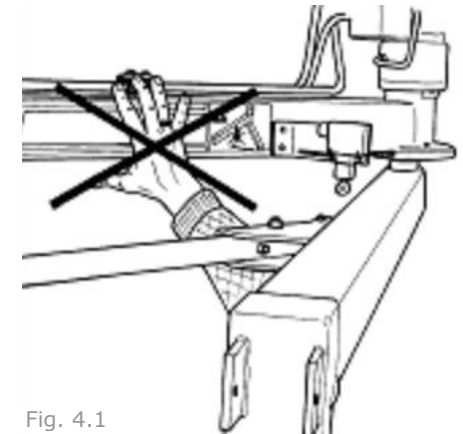

Fig. 4.1

- Squeeze Danger between the Rollers and the Main Frame

During the wrapping process the bale rotates on two rollers. When the rollers are in motion there is a danger of being squeezed.

- Squeeze Danger between Roller Arms and Main Frame (Inwards)

When loading a new bale, the roller arms move towards the main frame, Beware of the danger. Keep clear of this area.

- Squeeze Danger between Roller Arms and Main Frame (Outwards)

When loading or unloading a new bale, the roller arms move outwards. Beware of the danger. Keep clear of this area.

- Squeeze Danger Caused by Plastic Automation

At the end of the wrapping process the plastic is cut and held tight until the start of the next wrapping process. When the cutter arm moves down to lock the plastic, there can occur a squeeze danger between the cutter arm and the cutter holder. The cutter blade that cuts the plastic is very sharp; ensure to keep hands away from the cutter. (See Fig. 4.2).

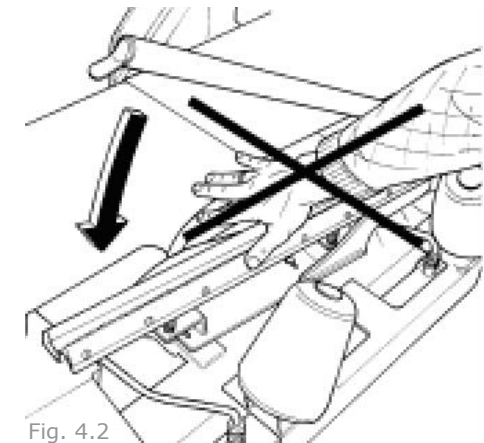

Fig. 4.2

Three Point Mounting

When the machine is mounted on the three point linkage, make sure that the lifting arms are tightened up so there is no sideways movement.



Front Mounting

If the machine is mounted on a front loader there must be a counterweight fitted to the three point linkage. It must be large enough to give the tractor good stability. Connecting heavy working implements often has an overall negative effect on the tractor's driving and braking capacity.

Transporting

When transporting on a public road there are certain safety measures that must be taken:

- Ensure the machine is in the transport position.
- Ensure the squeeze arm is fully closed.
- Ensure that the wrapping arm is not parked overhanging the sides of the machine.
- Ensure that the lights are connected and functioning correctly
- It is recommended that the film rolls be taken off the dispensers for road transport and put on the film carriers on the drawbar. This reduces stress on the machine and reduces the danger of the rolls being accidentally falling off on the public road.
- The machine is wide (2660mm) even in transport position, be aware of this especially on narrow roads.

Bale Wrapping Principles

The advantages of round bale silage are many, and include fewer feed units, a flexible harvesting system, large capacity and the possibility of selling feed units.

In principle, the same fermentation processes occur whether the fodder is placed in a silo or pressed into bales and packed in plastic, i.e. lactic acid fermentation in anaerobic conditions. The oxygen in the bale must be exhausted before fermentation begins.

The grass should be dried to approximately 30-40% solid content. The solid content can be determined by twisting the grass by hand. If drops of liquid are forced out of the grass, the solid content is less than 25%. Low solid content (wet grass) can lead to increased butyric acid fermentation if preservatives are not added to the grass. If the solid content is too high, (over 50%), normal fermentation will not take place and there will be enough oxygen in the bale to produce mould fungus.

The Baler

It is vital that the baler produces compact, well-formed bales, as misshapen bales can be difficult to wrap. Wrapping will also often take longer, thereby increasing the amount of plastic used.

Difficult Bales

When a misshapen bale is wrapped, it will have a tendency to move outwards or inwards on the roller. If the bale begins to move outwards, the machine must be lifted slightly at the rear edge to get the bale to rest against the support roller on the main frame. It can therefore be useful to use a hydraulic top link to make this adjustment easier.

If the bale to be wrapped is conical you must ensure that the sharp end is pointed at the tractor. It will then be easier to get the bale to lie correctly during packing. It is easy for such a bale to "turn" forward in the direction in which it is pointing, and therefore lie against the support rollers. If the bale is lying on a slope it must be picked up from the lower side. A hydraulic top link will again be advantageous.

Types of Plastic

A good type of plastic with good adhesive properties, and which is recommended for bale wrapping, must be used. The thickness of the plastic foil should be at least 25 μ . (25/1,000 mm). In order that the plastic tightens sufficiently around the bale, it is stretched before being wrapped, so it is somewhat thinner when it is put on the bale. With short-term storage (up to eight weeks) it is recommended that bales have a minimum of four layers of plastic at the thinnest points, with at least 52-53% overlap.

For long-term storage, or when the grass is wet when it is wrapped, the bale should have 90-100 μ plastic (six layers) and the same amount of overlap. If thinner plastic is used, more layers should be applied. If it is very hot the plastic will be stretched further, and more layers should be applied. It is better to have slightly too much than too little plastic on the bale.

From experience, light colored plastic produces slightly lower temperatures within the bale, and tends to improve feed quality.

Storage Location

Care should be taken in finding a suitable location for the storage of bales. The storage location should preferably be prepared before the bales are laid out. An elevation close to well-drained roads is recommended. If the wrapped bales are simply placed on stubble there is a danger of the plastic being pierced. A tarpaulin or a thin layer of sand should therefore be laid where the bales are to be stored over the winter.



Bales should be stored in the shade as far as possible. This reduces the danger of air leakage in the bales. A bale which is stored in sunlight and which therefore undergoes greater swings in temperature "pumps in" a great deal of air in comparison to a bale stored in the shade. According to "Teknik for Lantbruken" [Technology for Agriculture] in Sweden, a bale stored in the shade has only 40% of the air leakage of a bale which is stored in sunlight.

Stacking / Protection

If bales are hard and well formed, they can be stacked vertically, but loose and misshapen bales with low solid content should not be stacked higher than one layer, as this could easily cause deformity and the danger of runoff will be increased.

Bales can also be stored on their sides. The layer of plastic is thicker here, providing greater protection against piercing.

Bales should be covered with a tarpaulin or a fine-mesh net to protect against birds and small rodents. If the plastic is pierced, it must be sealed with weatherproof, hard-wearing tape, preferably under the outermost layer of plastic. Ensure that the hole is adequately sealed.

For Best Wrapping Results...

1. Harvest the grass early.
2. Ensure the grass is dried out to 30-40% solid content. If there is a danger of rain, bale and wrap the grass anyway.
3. Take care not to mix any earth in with the grass.
4. Use a baler that produces even, firm bales. Bales 1.2mtrs in width and with a diameter of 1.2-1.5mtrs are preferred sizes.
5. Wrap the bales as soon after baling as possible; never more than two hours afterwards.
6. Use a good plastic type, applying six layers of plastic. This removes the need to use preservatives.
7. Store bales in the shade to reduce the danger of air leakage.

Mounting of the Machine

 Be careful! There is a danger of being crushed when working implements are fitted and connected. Carry out the fitting procedures slowly and carefully, and use separate and approved lifting equipment to make the work easier. Note the section on safety precautions and pay attention to the various safety decals displayed on different parts of the bale wrapper.

Three Point Linkage

TANCO AUTOWRAP 1120 model is intended for rear mounting to the three point linkage, Category 2. When attached to three point linkage, make sure the machine is level across the tractor. Tighten up and lock the lifting arms so there is no sideways movement.

Top Link

Adjust the top link of the tractor so that the machine is level with the ground. It is recommended to use a hydraulic top link, as this makes it easy to adjust the angle of the machine. During the wrapping process it is recommended to tilt the machine towards the tractor, as this will prevent the bale from falling off the rollers. (See Fig. 6.1).

Front Mounting

This machine can be equipped with attachment brackets for front loader or wheel loader. (Talk to your dealer for information regarding the mounting brackets available).

When front-mounted there must be a large enough counterweight fitted to the three point linkage, this is to secure the tractors stability.

Fig. 6.1

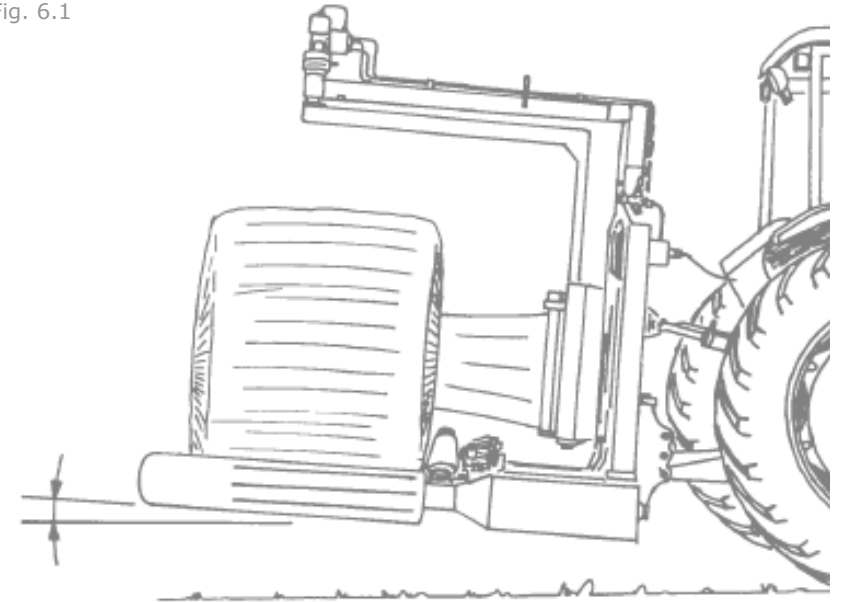

1120 EH Control Unit

The EH control units consist of the emergency stop button, a control cable, a fuse and a battery cable. The control unit should be attached to a suitable place in the tractor cab using the suction pad provided.

The Remote Control Unit is not Shock Proof, make sure that is fastened to a soft pad that secures a non-vibrating foundation.

Electrical Connection

The electric supply for the machine's remote control and electro-hydraulic components must come directly from the tractor's 12 volt battery.

The electric wires from the battery must have an area measurement of min. 2,5 mm². Connection to other contacts on the tractor can cause risk of malfunction and is not recommended.

Note:

Brown leader goes to the Battery's Positive Pole

Blue leader goes to the Battery's Negative Pole

1120 EH Control Box



1120 EH Hydraulic Connection

The hydraulic hoses between machine and tractor are equipped with 1/2" ISO Male Quick-Couplers. Ensure the oil pressure has been discharged before you connect the oil hoses using the tractor's hydraulic lever.

To make sure that the bale wrapper works properly, the tractors' oil pressure has to be at least 180 bar. The oil flow should be 15 - 25 liters per minute. The return pressure on the return must be as low as possible, and not exceed 10 bar. This should be measured with a gauge. It is recommended to use one single-working hydraulic outlet and arrange a free return circuit to the oil tank.

If you are unsure of what oil pressure the tractor gives, or what oil pressure the bale wrapper receives, please contact your machinery dealer. Generally all tractors have got some counter-pressure in their hydraulic return systems. Some tractors have more than others.

Note:

The Hose with the Red Cap shall be connected to pressure 'P' and Hose with Blue Cap to the return 'T'.

Open & Closed Center Hydraulics EH Models

The 1120 hydraulic system can be set up for tractors with Open or Closed Center Hydraulics.

Open Centre Hydraulics

Most tractors have a hydraulic system that gives a continuous output which flows through the valve on the machine and back to tank when no function is operating (Open center).

Note:

The TANCO AUTOWRAP EH Models are set-up for open centre on leaving the factory.

Close Centre Hydraulics

Some tractors (John Deere) have a hydraulic system that require the valve on the machine to allow no flow when no function is operating (Closed Center).

The hydraulic valve can easily be configured to operate in this way.

Simply push and twist the Manual Override on the Master Valve. (See Fig. 6.1)

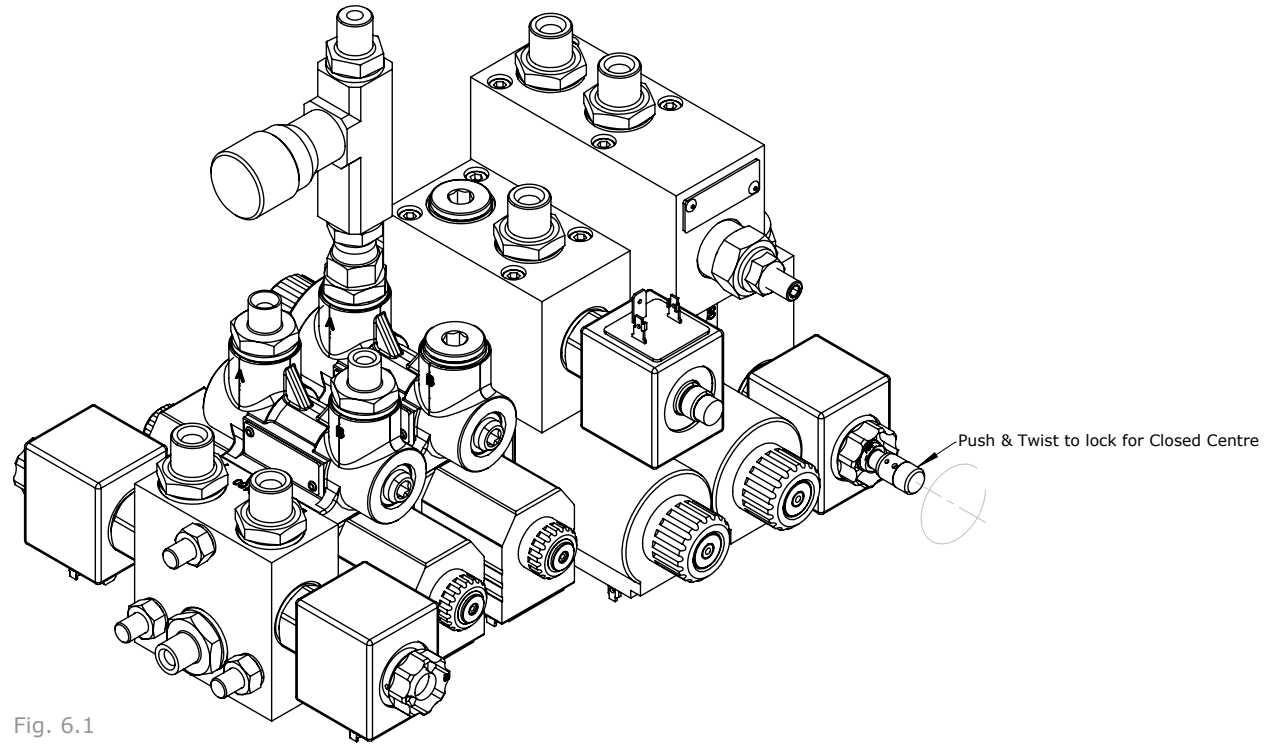

Fig. 6.1



LS Hydraulics

Many modern tractors have a "Load Sensing" (LS) Hydraulic System. This is most efficient as the pump remains on standby, pumping no oil until it gets a signal from the machine. It is possible to run this machine on a load sensing tractor with the standard valve.

Configure the valve for open centers and if possible adjust the flow from the tractor to give ~30 lts/min. This however means that that tractor is constantly pumping and you do not get the benefit of the efficiency of your load-sensing pump.

Tanco Autowrap strongly recommend that if you are running the machine on tractor with LS Hydraulics you fit the optional Load-Sensing Block (see Hydraulic Circuit). With this block fitted a Load sensing signal is transmitted in the form of hydraulic pressure via a hose for the LS Port on the LS Entry Block to the LS Connection on the tractor.

Note:

The LS Entry Block can be configured also to run on any other hydraulic system, open or closed center.

Check List:

Before using the machine it is recommended to follow this check list:

1. Make it a habit to discharge the oil-pressure before connection or disconnection of the hydraulic hoses. (By operating the hydraulic control lever inside the tractor). (Use the tractors hydraulic control lever).
2. Return-oil should be led directly to tank. Beware that if the counter pressure is too high, the security valve on the main block will release some oil. (See Chapter 9).
3. Hose with BLUE CAP = RETURN OIL.
4. Hose with RED CAP = PRESSURE.
5. Tie up loose hoses and Connection Cables so that no squeeze damages occur.
6. Start the tractor and try out the functions. A bale is not required for this test.
7. Check all connections, hoses and couplings. If there is any oil-leakage, it should be rectified immediately.

If any problems should occur, it is most likely that the failure is in the quick-couplers on the tractors pressure and return-connections.

Make sure that both the male and female-couplers opens properly for the oil flow, check these carefully. The best thing to do is to exchange the quick-coupling on the return side and arrange a "free return".

Your TANCO AUTOWRAP bale wrapper has been tested in practical operation in approx. 2 hours at the factory.

Emergency Stop (See Fig. 6.3)

This machine is equipped with safety guards on the Wrapping Arms, and its operation must be tested before work itself is started.

The Emergency Stop is to prevent the Wrapping Arm from damaging people and objects, when the machine is started and during the wrapping process. It consists of two safety arms that run in front of the film dispensers. When tripped they activate an electric switch, which gives a signal to the control box to activate the emergency stop.

When testing this function, start the Wrapping Arm, hold out an arm or any obstacle. The wrapping arm shall now stop before it hits the arm. Great care must be taken when testing this function.

To restart the machine the obstacle must be removed and the arm must be returned to its original position. The Auto Switch on the control box must be activated again. The wrapping may start again.



IMPORTANT!

GIVEN THE VELOCITY AND MOMENTUM OF THE ARM IT IS IMPOSSIBLE TO STOP THE WRAP ARM IMMEDIATELY. THE EMERGENCY STOP ARM IS PROVIDED TO HELP REDUCE THE RISK OF SERIOUS INJURY AND GREAT CARE MUST BE TAKEN WHEN OPERATING THIS MACHINE.

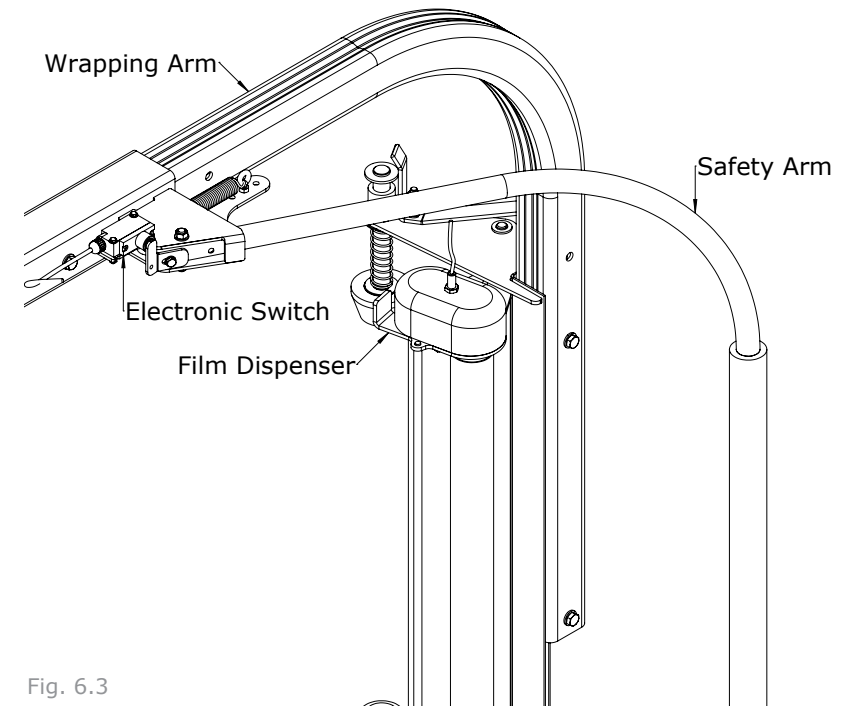



Fig. 6.3



Mounting of Plastic Film (See Fig. 6.4 & 6.5)

When loading a plastic roll, first ensure the Top Cone is pushed up to the latched position, then push back the Dispenser Insert until held in position by the Bottom Latch.

Place the Roll on the Bottom Cone and release the Top Latch.

 BEWARE OF FINGERS!

Pull the film between the rollers on the Dispenser Insert in the direction of the arrow, as shown below. (See also the sticker on the dispenser).

Release the Bottom Latch and allow the rollers to lie against the roll of film.
Pull the film from the roll and tie it to the bale.

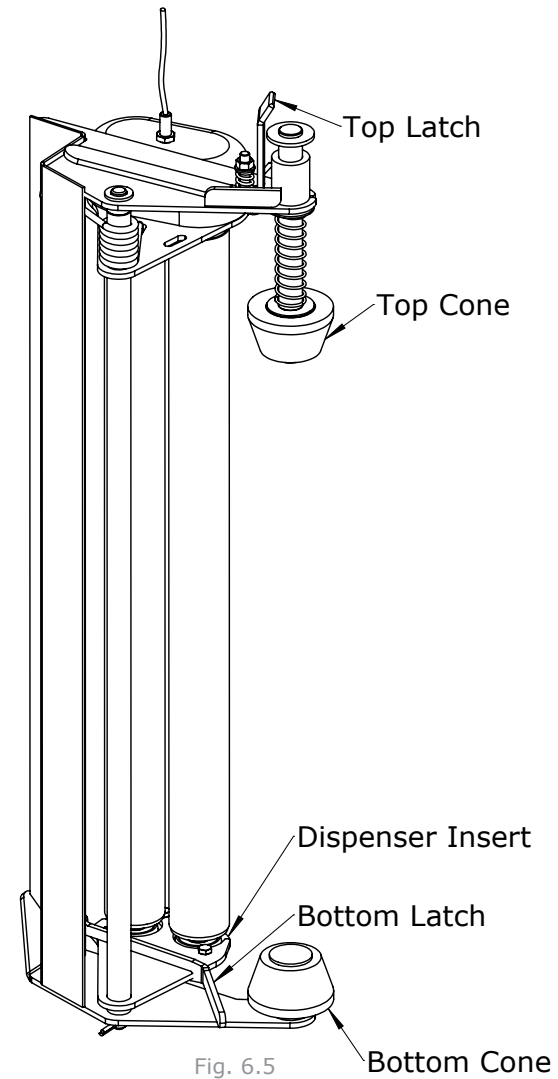

Adjusting the Height of the Dispenser

The standard film dispenser is designed for 750mm film. If using 500 mm film an adaptor is required which must be ordered separately. See parts book and contact your dealer.

The plastic film should hit at the middle of the bale wrapped (Fig. 6.6), and therefore it can be necessary to adjust the height of the pre-stretcher (See Fig. 6.7).

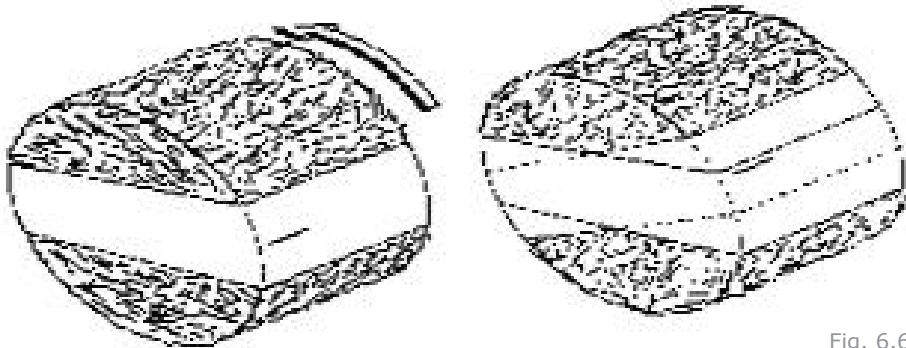

Fig. 6.6

Height Adjustment

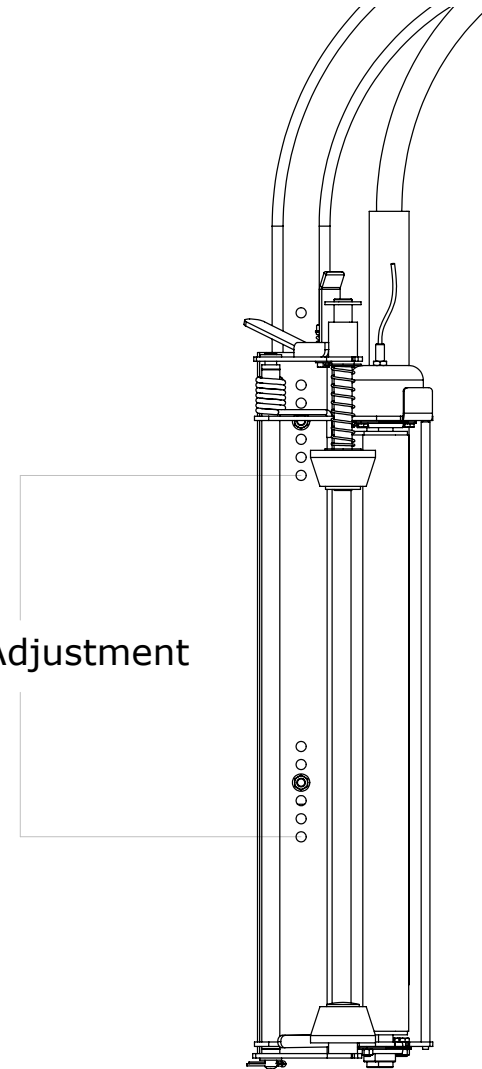

Fig. 6.7

Tanco Dual Stretch Dispenser

All Tanco Autowrap machines are supplied with a patented dual stretch gear system. This system enables a quick change of stretch levels on the Film Dispenser.

If the Gear Bolt is fitted in Position 1 (See Fig. 6.7), the top set of gears provide the stretch @ 70%. By removing the Gear Bolt from Position 1 and fitting it in Position 2, the bottom set of gears become the stretch gears giving 32% (for prestretched film) or optionally 55% (for use in hotter climates or with square bales).

Tanco Dispenser Gear Combinations

Inner Gear	Outer Gear	% Stretch
60 Tooth	35 Tooth	70%
58 Tooth	37 Tooth	55%
54 Tooth	41 Tooth	32%

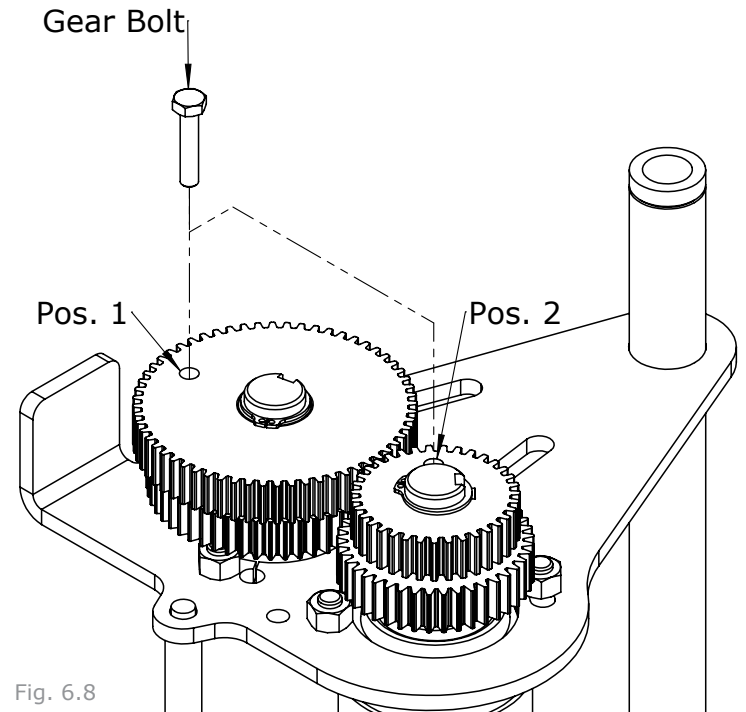

Fig. 6.8

1120 EH Controller

The Tanco Autowrap Bale Wrap Controller enables the operator to monitor and control the operation of the bale wrapper at any stage of the wrapping cycle.

There are 2 operating modes – Automatic and Manual. The Automatic Mode permits 'one-touch wrapping' to ease the workload on the operator. The controller is fully programmable to optimise wrapping performance. Bale counts are automatically logged in any one of 10 selectable memory stores, in addition to a grand total memory store.



IMPORTANT SAFETY INFORMATION!

Please read and understand the instructions for using this controller before operating the machine.

This controller is fitted with a push-button type On/Off Emergency Stop switch. Always ensure the controller is switched OFF via this switch before attempting any adjustment or maintenance to the machine.

Please follow ALL other safety instructions given in the manufacturers' Operator's Manual for this machine.

Controller Main Operating Functions & Display

The principal instrument features and operating functions of the Controller are shown in Fig. 7.1 overleaf.



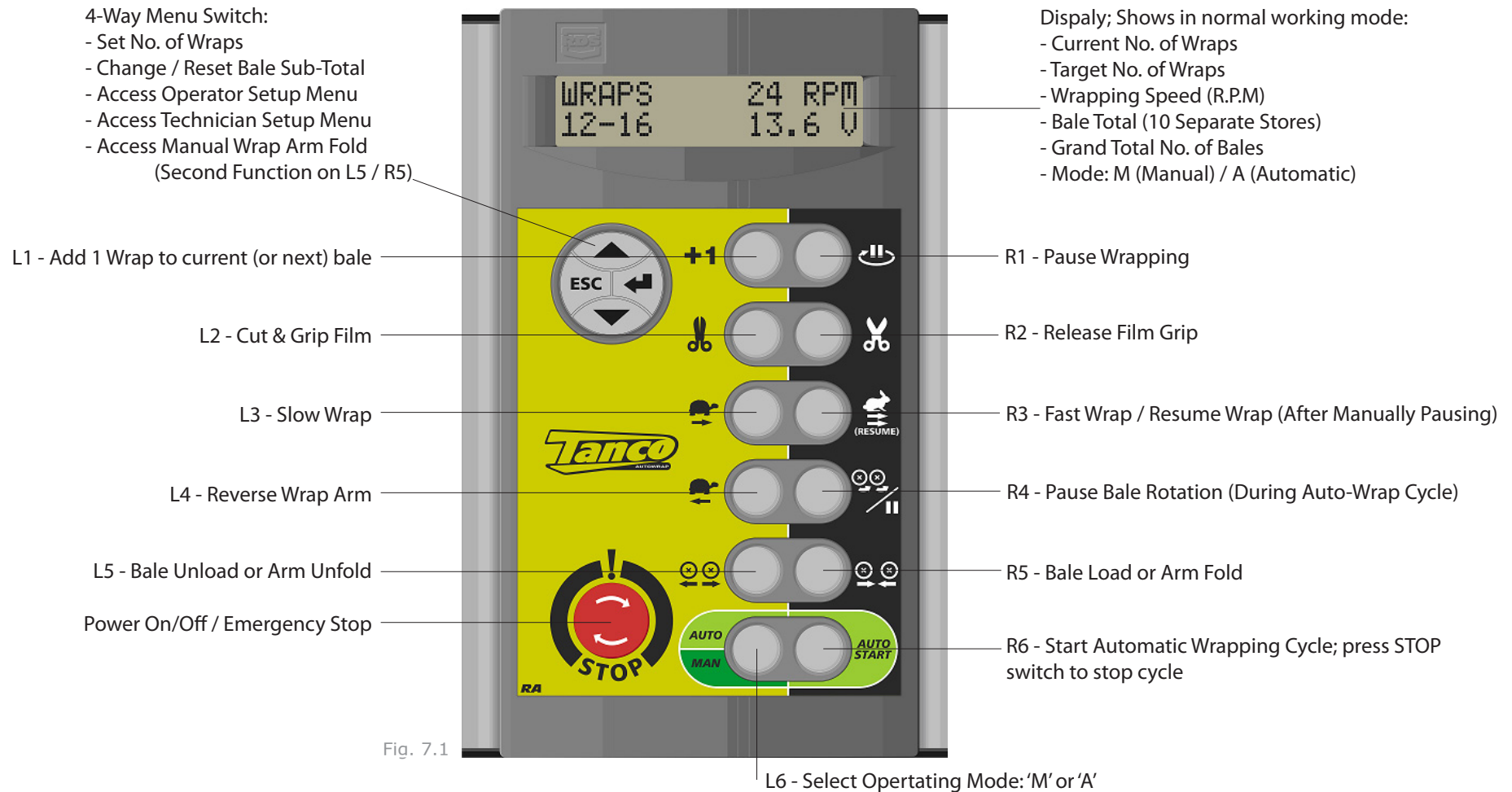

Fig. 7.1

Operation

Operation in Automatic mode

The controller is generally used in automatic mode for 'one touch wrapping'. Note the controller counts in steps of 2, because for each revolution of the wrapping arm two wraps of film are applied.

1. 'A' on the centre of the display indicates that the controller is set in Automatic mode. If not, press (L6) to select.
2. With the rollers in the open position (step 5), bring the machine up to the bale.
3. Press (R5) to move the rollers to the closed position.
4. Press (R6) switch to commence the automatic wrapping cycle. The wrap arm will first unfold to the straight position. It will then complete the target number of wraps, on the last half revolution the wrap arm will return to the folded position, come to a stop after passing the cutter and reverse to the centre.
5. Press (L5) switch to move the rollers to the open position to unload the bale.

Manually Interrupting an Automatic Wrapping Cycle

Press (R1) to bring the wrapper to a controlled stop. Pressing (R3) will continue the Auto-Wrap cycle from where it stopped.

 For safety reasons; if it is necessary to work on the machine (e.g. in the event of a film break or the film running out), then it is strongly recommended that you then switch the controller off via the red stop button and disengage the machine power source. Pressing (R3) after switching the controller back on will resume the auto-wrap cycle from where it stopped. Unless it is an emergency situation, do not bring the machine to a stop by pressing the red stop button as this will impose unnecessary strain on the machine.

Manual options in Automatic mode

With the controller in automatic mode, the following manual functions are possible.

- Slow Wrap (L3): This button will rotate the wrap arm at slow speed (not during an automatic wrapping sequence).
- Fast Wrap (R3): This button will rotate the wrap arm at normal fast speed. This button will also resume an automatic wrapping cycle if interrupted.
- Reverse Wrap Arm (L4): This button will rotate the wrap arm in reverse at slow speed (not during an automatic wrapping sequence).
- Pause Bale Rotation (R5): Holding down this button during an automatic wrapping sequence will stop the bale rotating and so will add more film to a particular part of the bale. Release the button when sufficient additional film has been applied.
- ADD 1 WRAP (L1): Each time you press this button an additional wrap will be put on the current bale if the wrapping sequence is in progress or onto the next bale if the automatic cycle has not yet been started. You can add as many wraps as required.

- Rollers Out or Wrap Arm Unfold (L5)

This button has two functions; its primary function is to operate rollers out to unload the bale. If the programming factor Roller Out is set to 0.0 in the Operator Setup on the controller then this button must be held down for the duration of the unloading operation. If a time is set for Roller Out then one touch of this button will trigger the function to operate for that time. In M manual mode the button must be held down for the duration of the unloading.

This button also manually performs the wrap arm unfold (to the straight position) function. To get it to change to this function hold down the Esc button (left side on 4 position button) for 5 seconds. ARM will flash on the display. To revert back to the primary function of Roller Out just press the Esc button again, ARM disappears from the display. In the automatic wrap sequence this unfolding function is performed automatically.

Note the Wrap Arm Fold and Unfold apply to the 1120 Model only.

- Rollers In or Wrap Arm Fold (R5)

This function operates in a similar fashion to the above Roller Out/Wrap Arm Unfold, just both function operate in the opposite direction.

- Pressing the Auto/Start (R6) button during an automatic wrapping sequence (after 4 or more wraps) will finish the sequence on the next rotation of the arm. The arm folding and cutter functions will operate as normal.

Operation in Manual mode

'M' on the display indicates that the controller is set in manual mode. If not, press (L6) to select.

In manual mode you have total control of every stage of the wrapping cycle.

Controller Outputs

The following are the electric solenoid valves powered for each machine function. The vale numbering corresponds to the numbers on the electric cables to the valves.

Note: Valve 7 (Master Valve) is powered for all functions.

Operation	Powered Solenoids		
Loading	7	5	6*
Wrapping:	7	4	
Unloading:	7	5	8
Reverse:	7	9	
Arm Unfold:	7	9	
Arm Fold:	7	11	
Cutter Open:	7	1	
Cutter Close:	7	2	

* In fast speed

The Display Menu

The Display menu is divided into 3 sections. At the top level are the settings used during the daily work with the machine – i.e. Store totals and No. of Wraps. The Operator Setup section enables the operator to perform adjustments to the machine operation – e.g. time duration and time delay settings during the automatic cycle.

The 'Technician Setup' menu is not normally accessible to the operator without a PIN access code. 'Technician Setup' is not covered by this manual.

Use the 4-way switch to navigate the menu. Each menu screen indicates which keys to press to make the settings. The instrument will default back to the main operating display after 30 seconds if no other key is pressed.

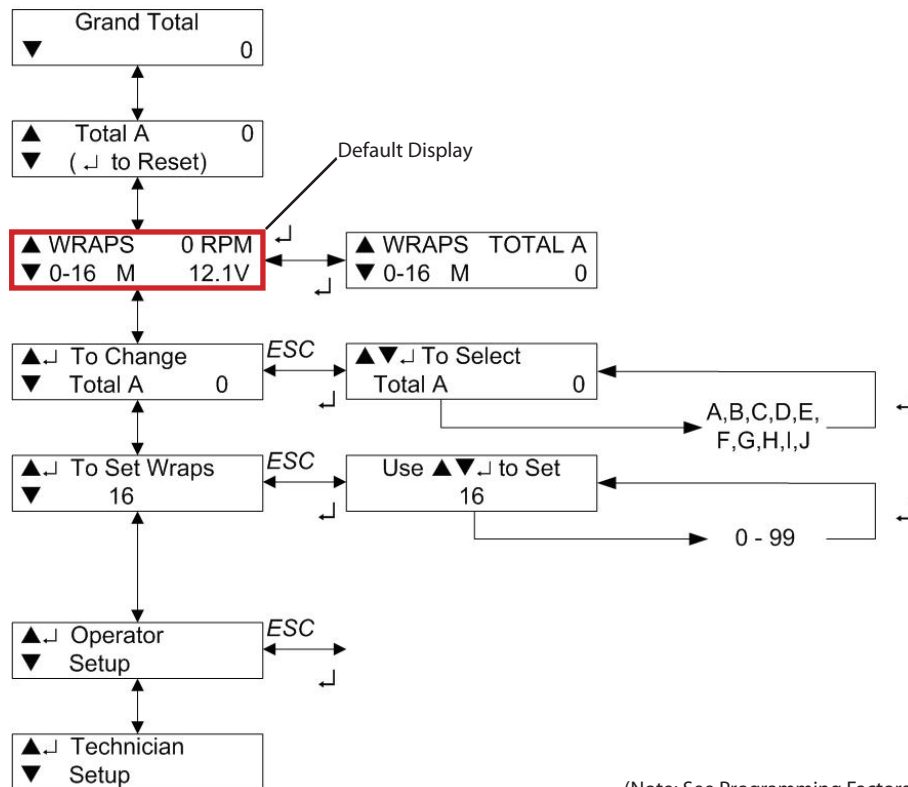

(Note: See Programming Factors)

NOTE: There are additional sequences selectable in the Operator Setup menu but not shown in the table. These sequences are for wrapper models to which this manual does not apply. Please refer to the Operator Setup Menu for further explanation of the Operator Setup functions given in the table above.

Selecting a Store Total

There are 10 individual memory registers labeled 'Store A' to 'Store J' for bale totals. Each time a bale cycle is completed, the currently selected store total and the grand total increments by 1.

The currently selected store is displayed on one of the two screens selectable in the normal operating mode.

The default setting is Store A. To select a particular store, navigate the display menu using the 4-way switch.

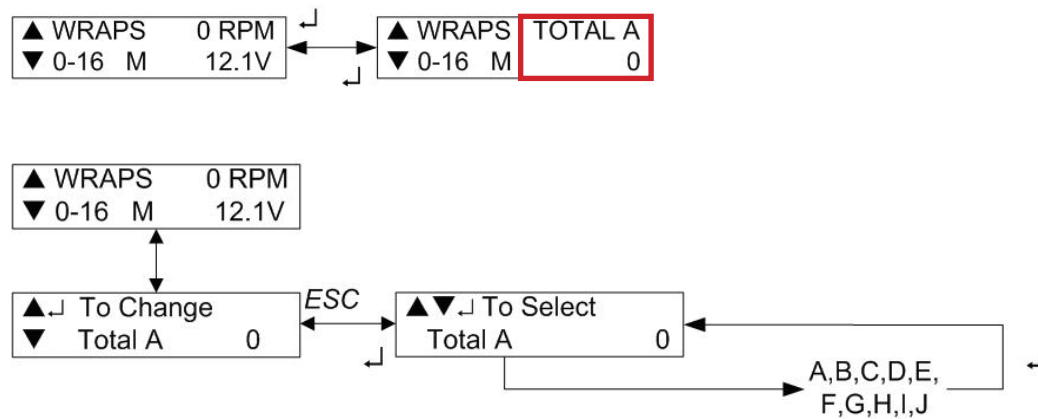

Press the Up/Down arrow keys to select the store, then press the ENTER key to confirm the selection.

Resetting a Store Total to Zero

Stores A to J can be individually reset to zero at any time. The Grand Total store cannot be reset. First select the store to be zeroed, and then navigate the display menu as shown below.

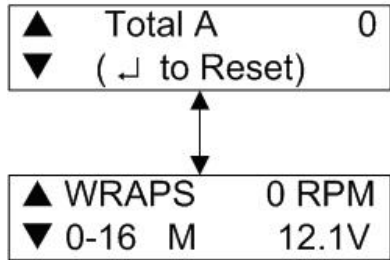

Press the ENTER key to reset.

Setting the Number of Wraps

The default number of wraps is 16. You can set the target number from 0 to 99 by navigating the display menu as shown below.

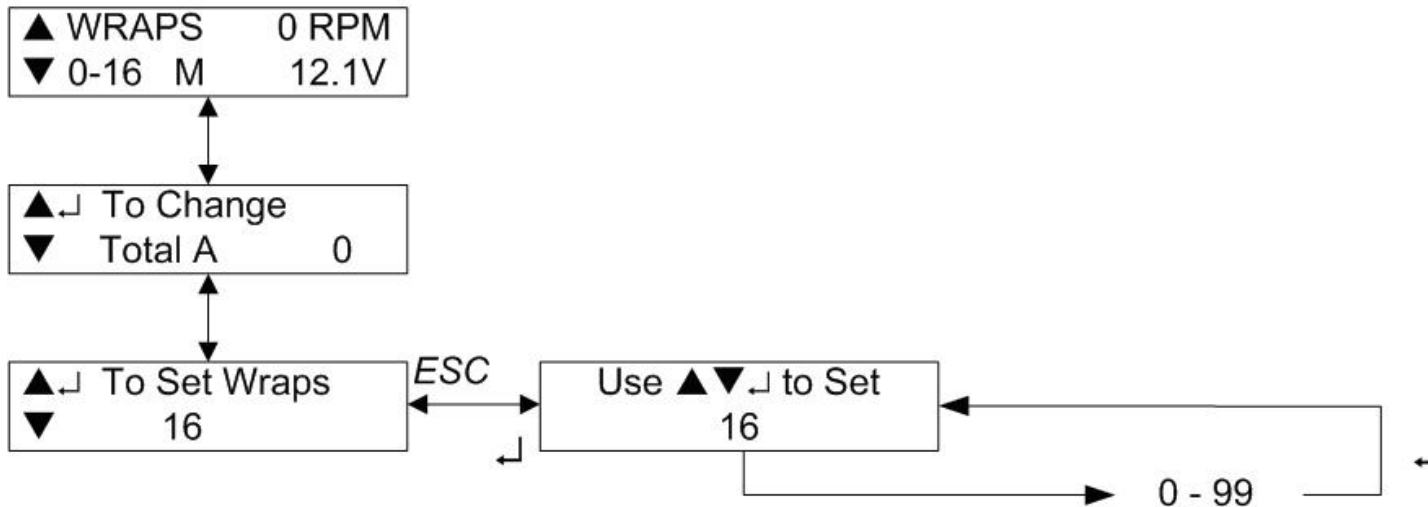

1120 Programmable Factors - Operator Level

Menu No.	Operator Level	Default	Units	Notes
N/A	Target No. of Wraps	16		
4.01	Contrast	2		
4.02	Film Break	OFF		Switches On or Off Film Break Sensor
4.41	Remote Type	RF		Sets Controller For Remote Control Type (Optional Extra)
4.23	Wraps to Release	*1	Pulses	Number Of Wraps To Cutter Releasing Film
4.25	Release delay	0.5	Seconds	Delay From Wrap Arm Passing Sensor To Cutter Opening
4.26	Delay To Slow	1.0	Seconds	Time From Wrap Arm Passing Sensor On Last Turn To Speed Changing From Fast To Slow
4.27	Delay To Stop	1.2	Seconds	Time (Passed Sensor) To Stop The Wrap Arm
4.28	Reverse Time	0.6	Seconds	Time Wrap Arm Reverses At The End Of Wrapping Cycle
4.29	Rotation After	0.0	Seconds	Not used on 1120
4.37	Roller In	0.0	Seconds	Sets Roller In Time For Automatic Loading; If Set To 0.0 Manual Must Be Held Down For Duration Of Loading
4.38	Roller Out	0.0		Sets Roller Out Time For Automatic Unloading. (As Above)
4.35	Language	English		Sets Controller Language

1120 Programmable Factors - Technician Level (Pin 1,2,3,4)

Menu No.	Technician Level	Default	Units	Notes
5.01	Sequence	1300x2		Sets Controller Program For Machine Model
5.15	Slow Start Time	2.5	Seconds	Time Wrap Arm Runs In Slow Speed at Start Of Wrapping
5.16	C&S Open Time	0.4	Seconds	Cutter Opening Time
5.17	C&S Close time 1	3.0	Seconds	Cutter Closing Time During Wrapping
5.18	C&S Close time 2	2.0	Seconds	Cutter Closing Time At End Of Wrapping
5.23	Bale Indexing	Off		Not used on 1120
5.24	Reverse Enabled	YES		Enables / Disables Wrap Arm Reverse Function
5.48	Arm Unfold	2.5	Seconds	Time For Wrap Arm To Unfold to Straight Position At The Beginning Of Wrapping
5.49	Delay to Fold	0.5	Seconds	Time After Wrap Arm Speed Changes to Slow Speed to Wrap Arm Folding (at End of Wrap Cycle)
5.53	1-D Rolls Stop	1.0	Seconds	Rollers Intermittent Stop Time For 1 Film Wrapping
5.58	1-D Rolls Rot.	1.3	Seconds	Rollers Intermittent Rotation Time For 1 Film Wrapping
5.52	Rot. After Wrap	Off		Not used on 1120
5.25	RPM Alarm	35	Seconds	Maximum Wrapping Arm Speed
5.28	Set Default			Sets Controller Back To Its Default Settings

Operator Setup Menu

The default settings for the machine are developed by Tanco for optimal operation of the machine. However, the operator can change certain parameters in the 'Operator Setup' menu to take account of operational conditions.

Operating Instructions

We shall now go through a complete wrapping process, from loading to storage place, and explain the practical use of the Tanco Autowrap 1120.

Fitting Rolls of Film

Remember that the plastic film ends have to be locked in the Cutter/Film holder before starting the wrapping. Take care when doing this.

Bale Height Adjustment

The dispensers should apply the film to the centre of the bale. The 1120 is set up as standard to do this on 1200mm diameter bales with the roller arms fully closed. If larger diameter bales are being wrapped then the arm stop pins should be used to limit the closed height of the rollers, this lowers the height of the bale on the machine. This gives clearance between the top of the bale and the rotating arm and also gets the film applied to the centre of the bale.

Setting the Speed of the Wrapping Arm

The wrapping arm speed is adjusted with a valve (1) located at the rear of chassis adjacent to the oil filter (2). (See 9.1).

Clockwise rotation reduces arm speed, anti clockwise to increase speed. It is recommended that the wrap arm speed is not increased above 30 RPM because above this the wrap arm will "catch" more air, and this air may not be able to evacuate from the bale. The result is bad fodder.

NOTE: Max. allowed wrapping arm speed is 35 revolutions per minute.

REMEMBER!

Increased speed of tractor engine does not increase the wrapping speed, it only increases the oil flow into the system, this may increase the temperature in the hydraulic system.

Overlap - 1120 EH Model

Overlapping on the 1120 model is set for two rolls of 750mm wide film. The wrap arm and roller speeds are synchronised so the roller speed will automatically change with the arm speed to maintain correct overlapping.

How Many Layers of Plastic Film?

When the bale is completely covered with film, read the counter that displays the number of revolutions done by the wrapping arm. Add 1 to this number and multiply by 2 or 3, depending on how many layers of film you want to have.

- * 4 layers - multiply by 2.
- * 6 layers - multiply by 3.

As long as you wrap bales with the same diameter, you can stop at the same number every time. It would be recommended as a minimum to apply 18 wraps to 1.2m diameter bale.

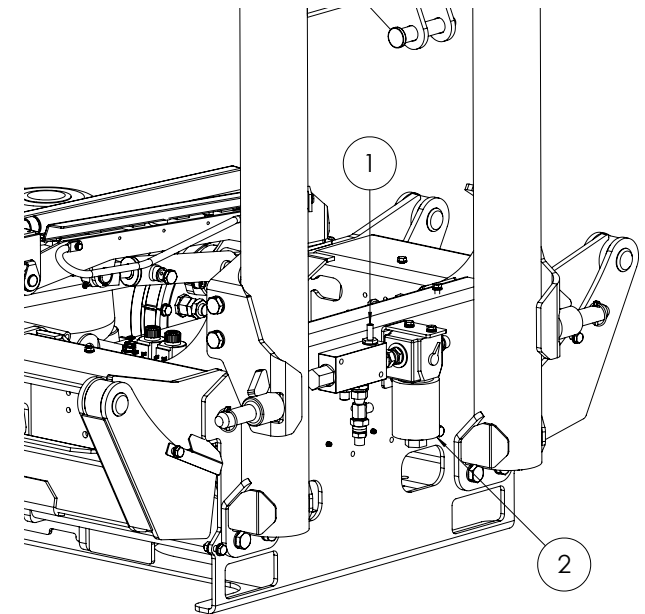

Fig. 9.1

Overlap - 1120 EH

The bale roller speed can be independently adjusted relative to the wrap arm speed. This allows the film overlapping to be manually adjusted and therefore must be set by the operator. To do this, first set the wrap arm speed as detailed in the previous section.

Load a bale and put a wrap of film on to it. With a marker put a line in the centre of the strip of film on the bale. Adjust the roller speed so this line is just covered by the next strip of film applied. 53% is ideal overlapping. Overlapping should be checked when bale size or bale quality changes.

The speed of the wrapping arm on the 1120 model is set by the valve (2) at the rear of the chassis adjacent to the oil filter (1) (clockwise rotation reduces the speed), the roller speed can be adjusted by turning the knob of the valve (3) directly below the wrap arm speed adjustment valve (clockwise rotation increases the speed) (see Fig 9.2).

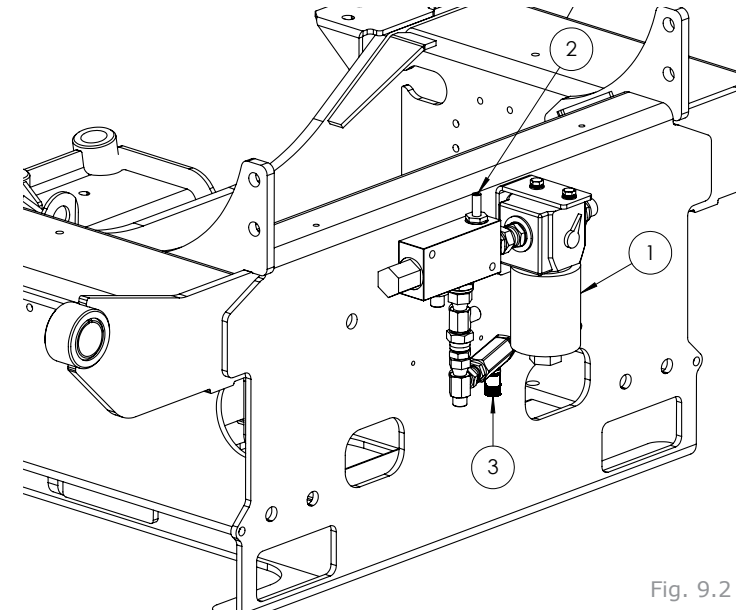

Fig. 9.2

Loading

Set the machine height with the tractor lift arms so there is approximately 300mm clearance between the rollers and the ground. It is very important that the rollers do not hit the ground when loading as this can damage the rollers and overload the roller drive. Open the rollers to the maximum. Drive in under the bale. Close the rollers fully to lift the bale clear of the ground. See Controller Information for setting controller for automatic one touch loading. To ensure that the bale does not creep off the rollers while wrapping it is important that the rollers are inclined towards the tractor, the machine may need to be raised to achieve this.

Start Wrapping

Because of the unique folding design of the 1120 wrapping arm it is easier to operate the wrapping process in automatic A mode rather than in M manual. The comments in brackets below are the programmable factors on the controller that govern the function that is happening.

The folded wrapping arms should be parked in the centre of the chassis before commencing the automatic wrapping sequence.

The film cutter releases the ends of the films (after, Wraps to Release).

Note the controller counts in steps of 2, because for each revolution of the wrapping arm two wraps of film are applied.

On the last revolution of the wrapping sequence the arm steps down to slow speed (after Delay to Slow time past the sensor).

The wrapping arm folds the dispensers together (after Delay to Fold time).

The cutter opens.

The two dispensers rotate together past the opened cutter (for Delay to Stop time).

The cutter closes (for C&S Close Time 2)

The wrapping arm reverses to the centre of the machine (for Reverse Time)

The bale is now ready for unloading.

Unloading

As with loading make sure that the rollers do not touch the ground when unloading.

Storage Place

At the storage place the bales should be placed systematically. Start at the right-hand side, and stack to the left. The machine is lowered, but not all the way down to the ground. The rollers must not hit the ground. Push the "rollers out" button to open the rollers and drop the bale to the ground. Drive the tractor carefully away from the bale. Try to avoid touching the bale with the rollers. Place the next bale to the left of the first one so that the loose film end on the last bale will be locked. To be sure we recommend that you check that the film ends are securely fastened, and eventually fasten them a little bit better when you have stacked the bales.

If the machine is front mounted, the bales can be staked upon each other.

Electro-Hydraulics

Note: There are 3 basics, which must ALWAYS be followed if the machine is to function correctly.

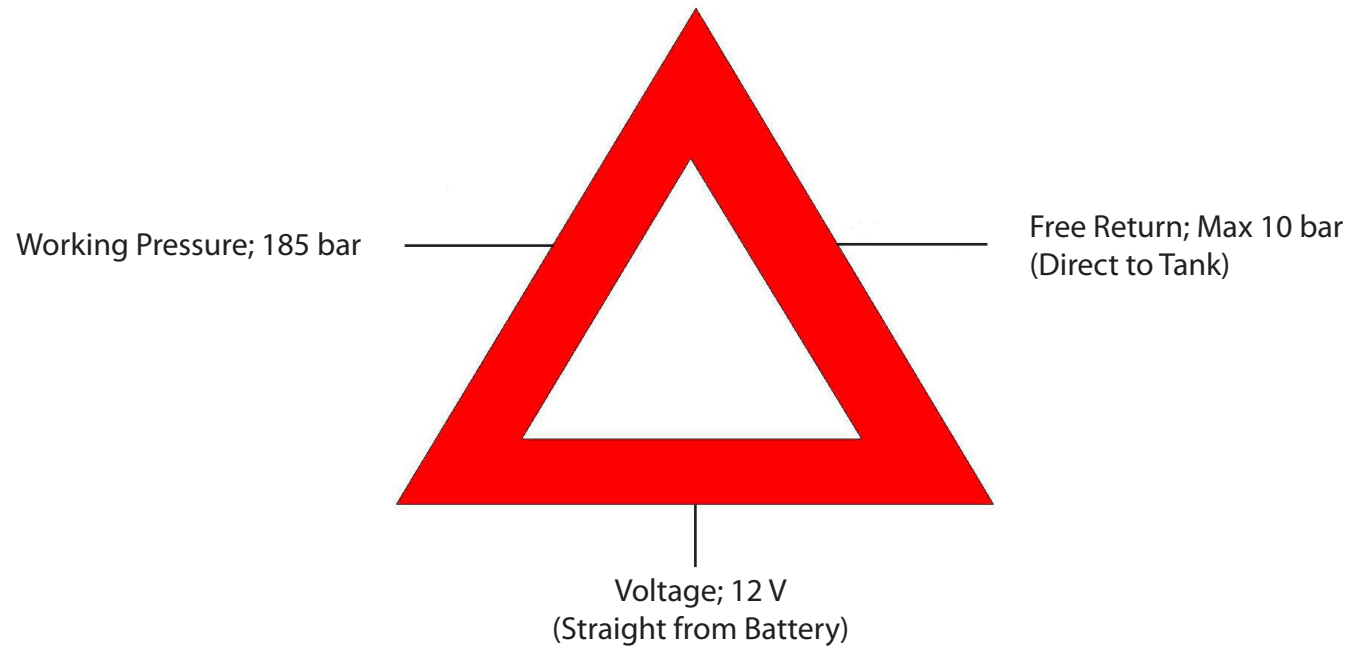

1120 Hydraulic Circuit

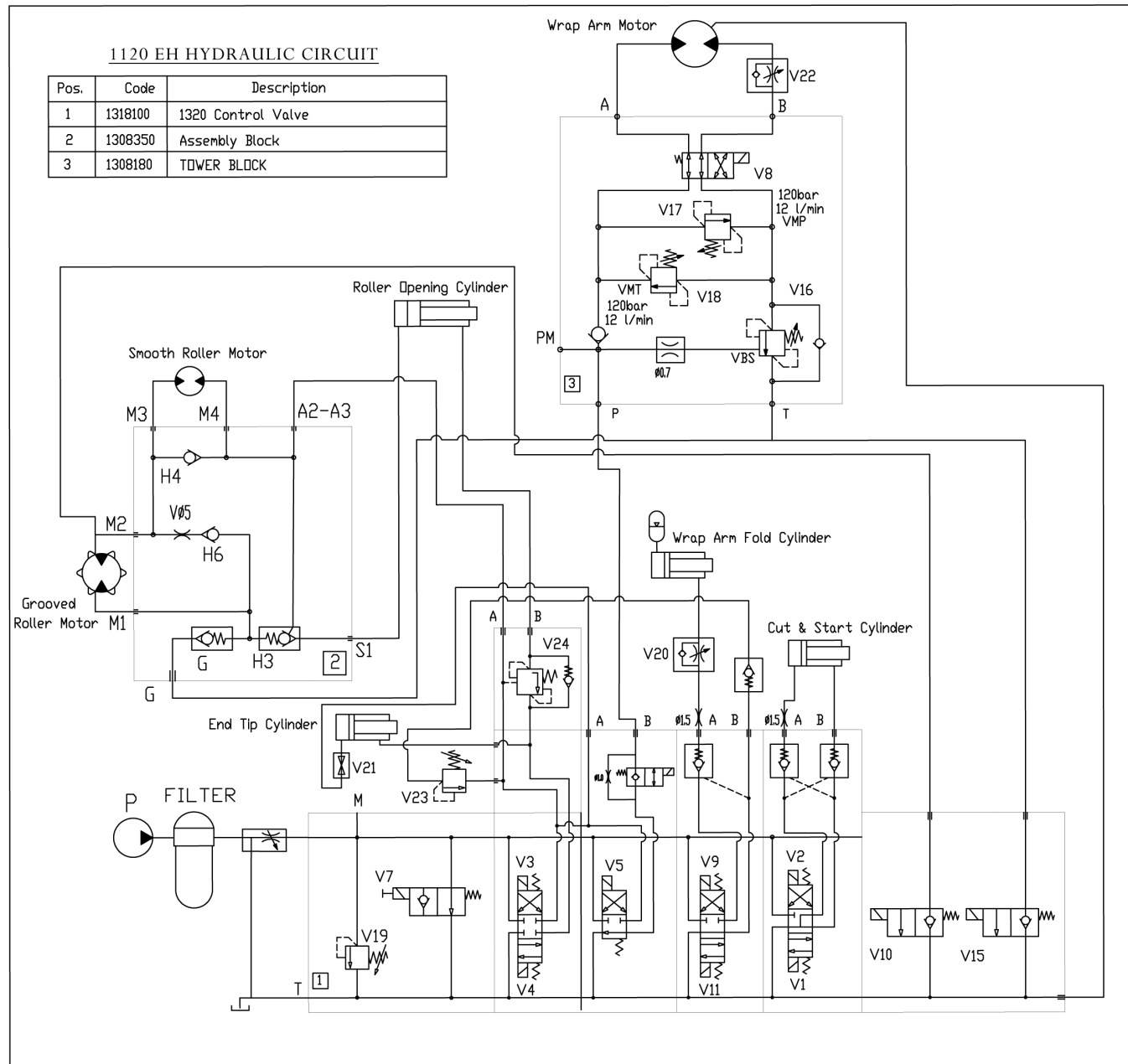

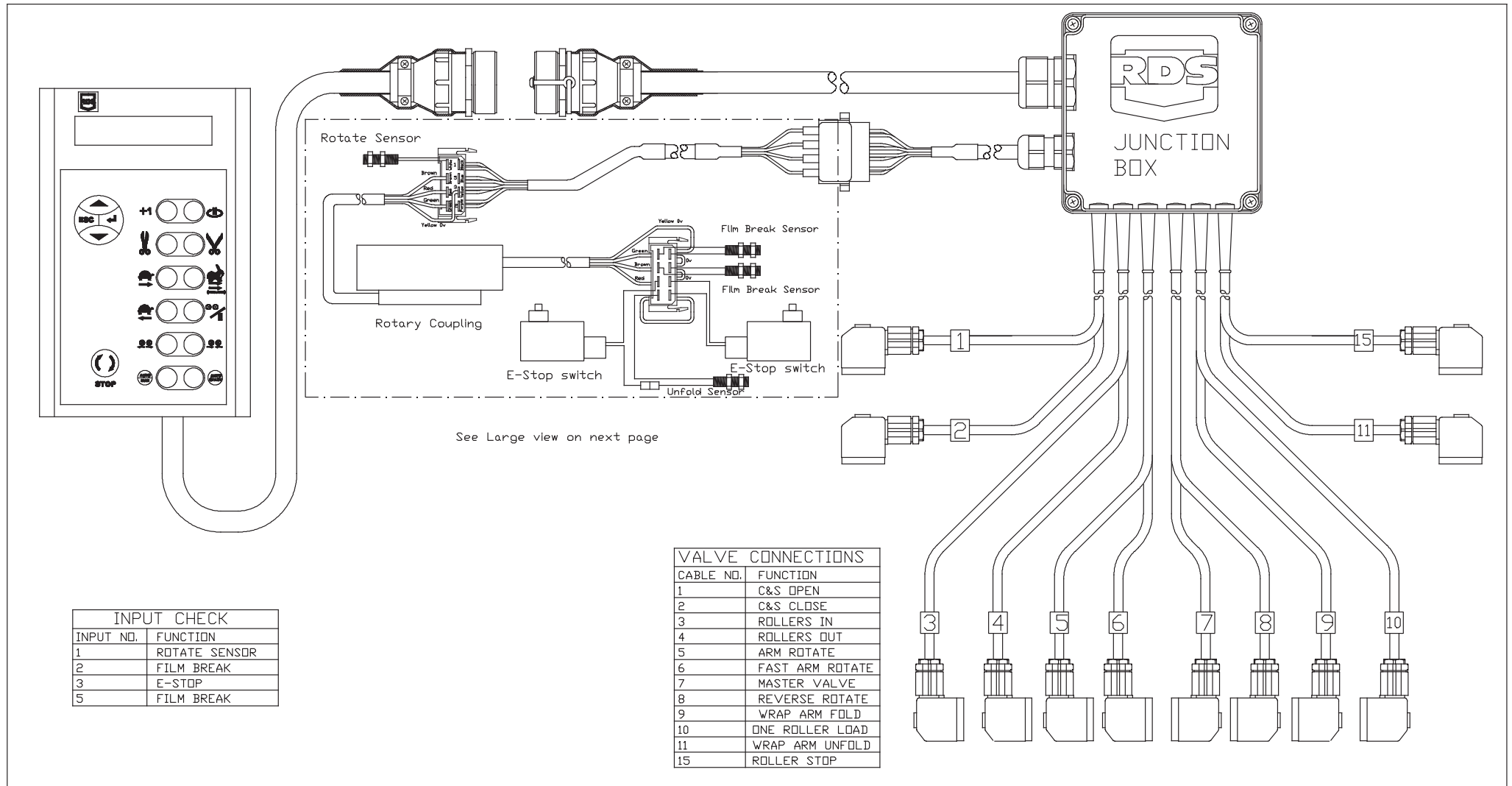

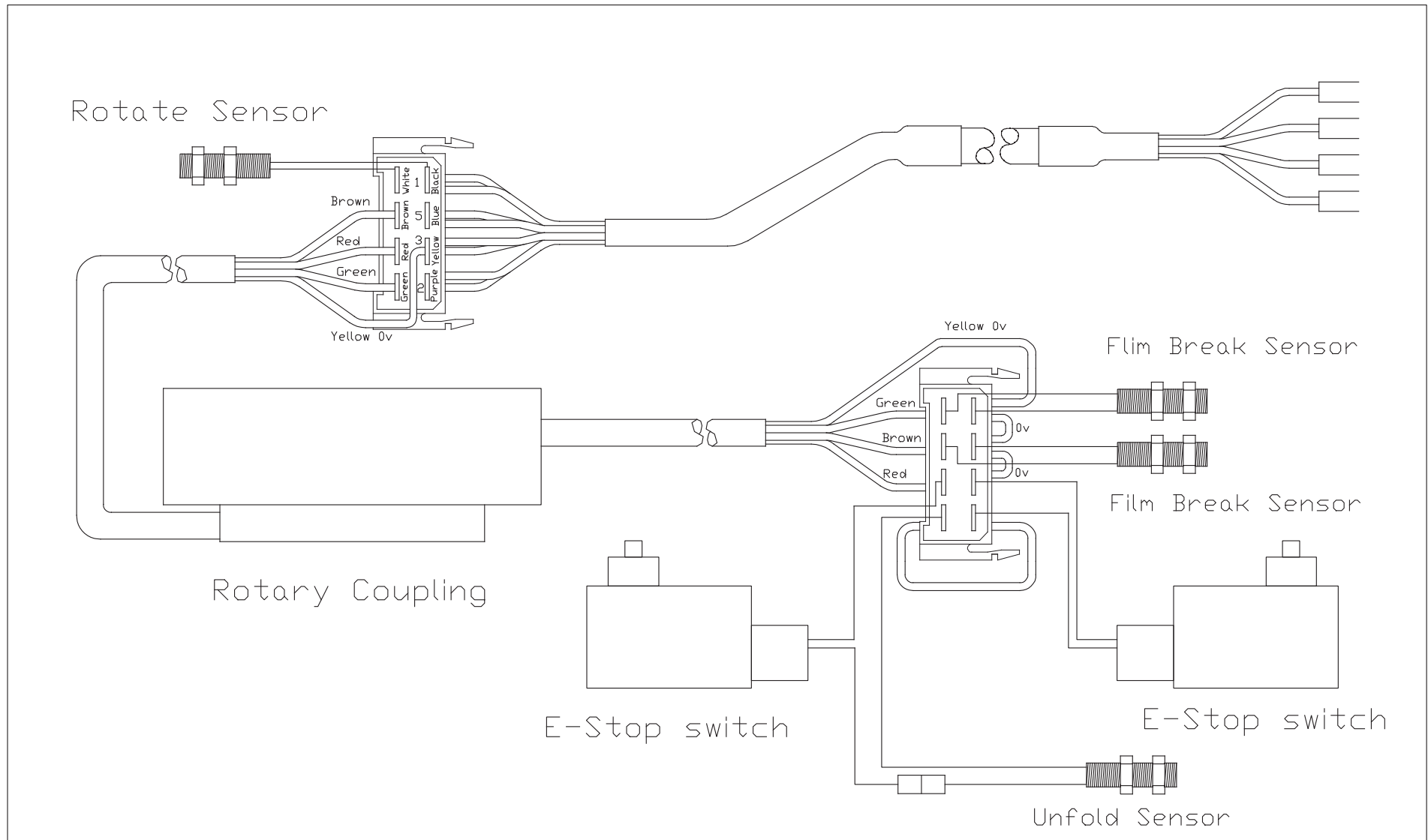

Description Of EH Modles Hydraulics

The 1120 is driven from the hydraulic system of the tractor. The hydraulics of the machine can easily be changed from "Open Center" to "Closed Center" hydraulic system.

The number on the electrical lead to the solenoid corresponds to the valve number. Their functions are as follows:

Valve (1) Cutter Open.

Valve (2) Cutter Close.

These valves open and close the film cutter

To prevent the Cutter creeping open, there is a load holding valve on top of the cutter section of the control valve. There is a 2mm speed control orifice in the bottom port of the cutter section.

Valve (3) Rollers In.

This valve operates rollers in for loading

Valve (4) Rollers Out.

This valve operate rollers out for unloading.

Valve (5) Arm Rotate.

This valve powers the wrap arm and table rollers.

Valve (6) Fast Arm Speed.

At the beginning and end of the wrapping sequence the wrap are goes in to slow speed. This valve is power for fast arm speed. When this vale is not powered the oil to the wrap arm goes the an orifice and so rotates at slow speed.

Valve (7) Master valve.

This valve is powered for every function.

Valve (8) Reversing Valve.

This valve is mounted on the tower valve, it reversed the direction of rotation of the wrap arm.

Valve (9) Wrap arm Fold

This valve folds the wrapping arm from the straight position to the position where both dispensers come together.

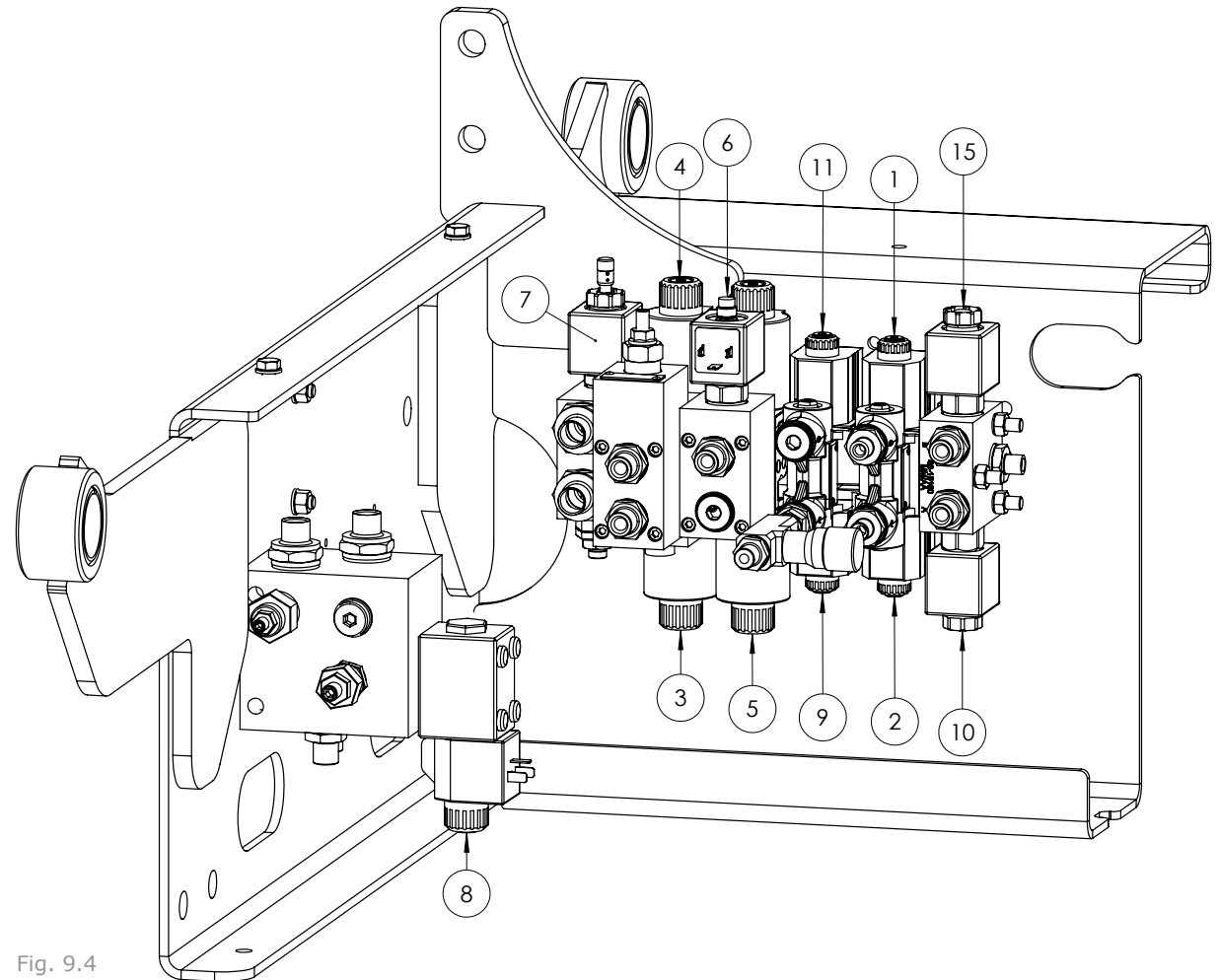

Fig. 9.4

Valve (10) One Roller Load.

This valve is powered during loading, it diverts the oil to tank between the two rollers so that for loading only the drive roller rotates.

Valve (11) Wrap Arm Unfold.

This valve unfolds the wrapping arm to the straight position.

Valve (15) Roller Stop.

This valve stops the rollers turning during an automatic wrapping sequence. It is pulsed on and off to reduce the roller speed when the film break sensors detect that one film has broken. It can be manually operated by pushing button R4 during wrapping.

Valves 16,17,18 are on the tower block

Valve (16) (VBS) Brake valve.

This is a pilot operated (8:1 Ratio) load holding valve. It makes the wrap arm run smoother in hilly conditions and holds the wrap arm in place when parked.

Valve (17)(VMP) Cross Line Relief Valve Forward

This valve limits the max. torque of the wrapping arm. If the inlet pressure exceeds the set value, it relieves the oil across to the outlet side of the motor. It is adjusted so that the pull force on the far end of the arm is approx. 35 KG. If it is set too high acceleration at the beginning of wrapping will be very sharp.

Valve (18)(VMT) Cross Line Relief Valve Reverse

This valve ensures a gradual stop for the wrap arm by limiting the pressure on the outlet side of the motor. If the pressure exceeds the set value, it relieves the oil across to the inlet side of the motor.

Valve(19) Main Relief Valve

The hydraulic system is equipped with a safety relief valve, which is preset to 185 bar. If this pressure is exceeded it opens and allow the oil from the pressure port to the tank port of control valve.

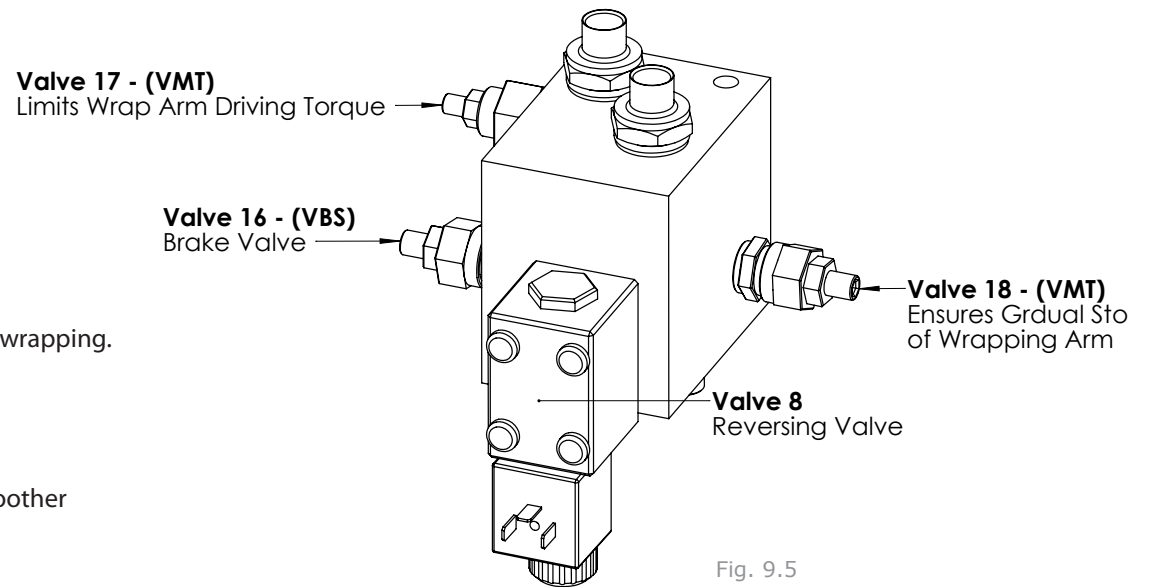

Fig. 9.5



IMPORTANT:

Valves 16 to 19 have been carefully set in the factory. Incorrect adjustment of these may cause damage to the machine. Always ensure that trained personnel only adjust the settings of these valves.

Check Points Prior to Troubleshooting

There are some general check points that have to be examined first if something is wrong with the machine. There are three basic assumptions that have to be fulfilled for the machine to function properly;

1. The oil pressure from tractor should be 180 bar.
2. The return flow of oil has to be as free as possible, max. 10 bar counter pressure.
3. Enough electric power to all functions.

Oil Pressure

In order to check that the oil pressure into the machine is high enough, a gauge may be applied to the oil pressure hose, for example on the quick coupler. If the pressure is less than 180 bar, there will be less power for the functions. The first place you trace this is at the ROLLERS OUT / IN.

Oil Flow

The amount of oil that the tractor delivers should be minimum 15 liters/minute for satisfactory operation of the machine, but it is recommended that it is 25 liters/minute.

Note: (Max. allowed oil amount is 40 liters/minute). Ensure that oil level in tractor's hydraulic system is correct and tractor's oil filter is changed regularly. REMEMBER! Large oil amount will mean that the Valves get hot. (Small Oil Tank will mean insufficient cooling).

Return Pressure

The return pressure can be too high. With high return pressure the machine's functions will get less power. High return pressure means also that you need more power to operate the valves. MAX. ALLOWED RETURN PRESSURE IS 10 BAR. We recommend "free return" directly to the tank.

Electric Power

It is important to check that all functions receive enough electric power. If not, some, or all functions may fail.

- Is the battery voltage high enough?

If the voltage falls below 9 volts the valves will not be able to open.

- Are the cables correctly connected to the battery?

Follow directions in chapter 6.

- Is the connection between battery cable and control unit OK?

Clean off the poles and check the plug.

- Is the connection between remote control unit and machine OK?

Change contacts if any doubt about the condition.

- Is the fuse on the battery cable OK?

PLEASE CONTACT YOUR DEALER IF YOU ARE IN DOUBT ABOUT ANYTHING.

(Remember always to give your dealer the serial number and production year of your machine when contacting dealer and when ordering spare parts).

Procedure of Troubleshooting

If the machine fails to operate correctly it must be determined if the problem is Hydraulic, Mechanical or Electrical.

Solenoid Valves

When checking if the Solenoid valves are receiving electric power, you do this in the following way:

1. Unscrew the nut that holds the solenoid.
2. The solenoid is easy to move without electric power.
3. Push the current function on the remote control. If the solenoid gets power, it will be difficult to move, it "sticks". This is the best and easiest way to check if the solenoid valve is receiving electric power. Another way is to hold a screwdriver up to the magnet. If it "sticks", the solenoid is receiving electric power.

The power supply to the valve can also be measured with a voltmeter, but then the contact must be connected to the solenoid, so it is using power. To have reliable functions, the voltage should not be lower than 11,5 volts, even if the solenoid valve usually works with a little lower voltage.

Only For Solenoid Valves to the Main Functions

If the electric supply is in order and one of the functions fails, the reason can be dirt that tightens or prevents the sliding shaft (spool) from moving.

Try to manoeuvre the function manually, by pressing the point of a screwdriver into the end of the valve housing. At the same time the corresponding switch on the control unit has to be operated to get electric power to the master valve. If the function is working again after this, the dirt may have been pushed out in the oil system and the machine can be operated normally again.



Take care so that the machines moving parts, do not cause damage to persons or objects.

The Machine Does not Function

- Even if the gauge shows enough pressure and there is no reaction in the machine. The reason could be that one, (or both), of the quick-couplers does not open for the oil, in this situation you should change the quick-couplers.

- The counter pressure may be too high.
Max. allowed counter pressure is 10 bar.

Make sure that the open / closed valve is correctly positioned.

Note: Disturbances of this type, a, b or c, are most likely in the first days that the machine is in use.

The Cutter will not Hold the Film

Is the cutter closing fully, if not increase the Cutter Close Duration 2.

If the cutter is creeping open, there may be dirt in the load holding, open and close the cutter a number of times to try to clear this. . If the problem develops over time then it may be due to seal wear in the cutter arms.

The Wrapping Arm will not Rotate

- The bolt that secures the wrapping arm during transport has to be removed so that the wrapping arm can move freely.
- Check valve 1 Screw all the way in and test. Adjust to required power.
- The safety valve, can be leaking, so that the oil is passing by the wrapping arm motor. Dismantle and try out if the sliding shaft can move freely .
- The control valve, may be blocked. Dismantle and check if the valve works normally. Do not use sharp tools.
- Check if the oil motor is working
Ask your dealer for advice BEFORE you make the problems bigger and repairing more difficult
- If the Emergency Stop has been activated. To start the machine the control box must be reset.

The Roller Will not Adjust

- Is the Solenoid valve receiving enough electric power?
When the power source is tapped by several users at ones, the voltage can fall so much that all the functions will cut out, or only the width regulating. Check the power source and measure the voltage.
- Check the Bypass Valve
If this is receiving enough power and has free flow, the problem must lie in the solenoid valve.

Periodic Maintenance

Bearings

All ball-bearings are packed with grease, and do not need any more maintenance.

Pre-Stretchers

If the machine is in daily use, the Gears under the plastic cover on the dispenser should be greased when needed.

Cutters / Film Holders

The cutter / film holder is pre-adjusted from the factory and does not need further adjustments. When replacing spare parts, it is necessary to adjust it. The springs for the U-shaped slot shall be adjusted so that they are almost completely squeezed together when the cutter-arm is all down.

Cleaning

The machine should be cleaned and oiled regularly and at the end of the wrapping season.



When using high pressure washing apparatus, care must be taken with the electrical installation.

Also make sure that water is not sprayed directly into the bearings, etc. Keep the control box protected from rain and water. If necessary use compressed air to dry electrical components.

Hydraulic Cylinders

Make sure that all hydraulic cylinders are closed when storing the machine.

Quick Couplers

Ensure that the quick couplers are kept clean and apply the dust caps after use.

Storage

The machine should be parked on a dry place during the closed season.

Oil Filter

The oil filter must be changed once a year.

Lubrication (See Fig. 11.1)

The table overleaf outlines the recommended lubrication requirements for components on the 1120 model; Note: We recommend that you change the oil in the Tower & Roller motors every 500hrs.

No.	Component	Type	Intervals
1	Width Ram	Grease	10hrs
2	Cut & Tie Ram	Grease	10hrs
3	Arm Folding Ram	Grease	10hrs
4	Wrap Arm Drive*	Oil	50hrs
5	Roller Drive**	Oil	50hrs
6	Dispenser Gears	Oil	50hrs

* Chain & Sprockets

** Sprockets

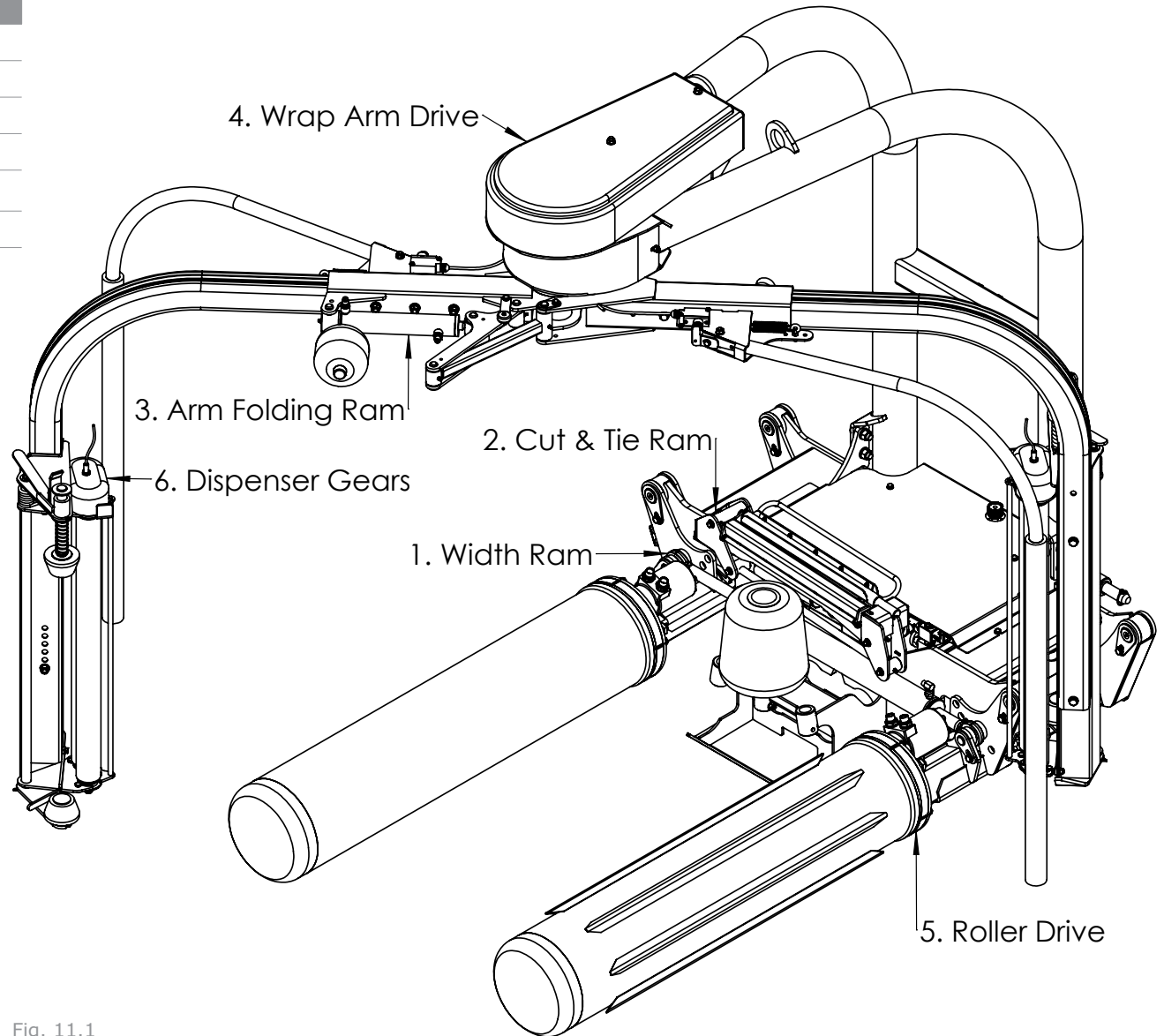

Fig. 11.1

GUARANTEE

Subject to hereunder provided, the sellers undertake to correct either by repair or at their election by replacement any defect of material or workmanship which occurs in any of its goods within twelve months after delivery of such goods to first user, with the exception of contractors or commercial users when warranty period is six months.

In respect of Autowraps the warranty period is for 12 months or 8000 bales, whichever occurs first.

The term goods when used in this document means the article or articles described in invoices as sold by the sellers but does not include equipment or proprietary parts or accessories not manufactured by the sellers. The sellers, however, undertake to pass on so far as they legally can to the first user the benefit of any warranty given to the sellers by the suppliers of such equipment, parts or accessories.

This understanding shall not apply to:-

- (a) Any goods that have been sold by the first user.
- (b) Any goods which have been injured by unfair wear and tear, neglect or improper use.
- (c) Any goods the identification marks of which have been altered or removed.
- (d) Any goods that have not received the basic normal maintenance such as tightening of bolts, nuts, tines, hose connections and fittings and normal lubrication with the recommended lubricant.
- (e) The use of any product on tractors exceeding the recommended horsepower.
- (f) Any goods that have been altered or repaired other than on instruction or with the written approval of the seller or to which any part not manufactured or having written approval by the sellers have been fixed.
- (g) Any second-hand goods or parts thereof.

Any allegedly defective part or parts returned to the seller must be sent carriage paid. No claim for repair or replacement will be entertained unless upon discovery of the alleged defect written notification is sent to the Sellers giving, at the same time, the name of the Buyer from whom the goods were purchased and the date of purchase, together with the full details of the alleged defect and the circumstances involved, also the serial number of the machine etc.

The sellers shall be under no liability to their Buyers and first or subsequent users of their goods or to any other person or persons for loss or damage howsoever arising in respect of either personal injuries or for arising out of, or in any other way connected with or arising from the manufacturer's sale, handling, repair, maintenance, replacement or use of its goods or the failure or malfunction of any of its goods.

Representation and/or warranties made by any persons (including Buyers and employees and other representatives of the Seller) which are inconsistent or conflicting with these conditions are not binding upon the sellers unless given in writing and signed by a director of sales.

CLAIMS

If you wish to make a claim under the guarantee:

1: Immediately, stop using the machine.

2: Consult with your Tanco dealer (supplier). He/She can download a warranty claim form on-line. This should be filled out and e-mailed to distributor and forwarded to relevant contact person in Tanco. Please ensure all relevant information is included on this form

3: Consult with your Tanco dealer (supplier) and have him forward your claim and the damaged item to Tanco.

1120 Spare Parts List (English)

We recommend that when you require spare parts you use only original parts.
When ordering spare parts please follow the following steps;

1. Identify the part you require using the detailed drawings.
2. Once you have identified the part you require reference the item number relating to the part on the item list where you will find the part number and description of the part you require. You will be required to give the complete part no and description when ordering your part(s).
3. When ordering you must give the Serial Number and Model Number of the machine.
4. All orders must go through your local Tanco Dealer, and must be either faxed or e-mailed to Tanco Autowrap.

1120 Ersatzteilliste

Wir empfehlen, nur Originalteile als Ersatzteile zu verwenden.
Befolgen Sie bei der Bestellung von Ersatzteilen bitte die folgenden Schritte:

1. Stellen Sie anhand der detaillierten Zeichnungen fest, welches Teil Sie benötigen.
2. Haben Sie das benötigte Teil identifiziert, geben Sie die Teilnummer auf dem Bestellschein an, mit dem Sie das/die Ersatzteil/e bestellen.
3. Geben Sie bei jeder Bestellung die Serien- und die Modellnummer Ihrer Maschine an.
4. Alle Bestellungen müssen über Ihren Tanco-Händler vor Ort erfolgen und müssen Tanco Autowrap als Fax oder E-Mail erreichen.

Liste des pièces de rechange 1120

Si vous avez besoin de pièces de rechange, nous vous recommandons de n'utiliser que des pièces garanties d'origine.
Pour toute commande de pièces de rechange, veuillez suivre les étapes suivantes :

1. Identifiez la pièce dont vous avez besoin à l'aide des schémas détaillés.
2. Après avoir identifié la pièce dont vous avez besoin, relevez son numéro de référence dans la liste des pièces dans laquelle vous trouverez également la description de la pièce requise. Lors de la commande, vous devez indiquer la référence et la description complètes de la pièce.
3. Lors de la commande, vous devrez mentionner le numéro de série et le numéro de modèle de la machine.
4. Vous devez effectuer toutes les commandes auprès de votre revendeur Tanco local et les faxer ou les envoyer par e-mail à Tanco Autowrap.

		BENENNUNG	DESCRIPTION	DESIGNATION
KAPITEL	SEITE			
CHAPTER	PAGE			
CHAPITRE	PAGE			
1	3		Chassis Assembly	
	4		1.1 1120 Chassis	
	6		1.2 1120 Roller Arms (Left)	
	8		1.3 1120 Roller Arms (Right)	
	10		1.5 1120 End Tip *	
	12		1.6 1120 Ground Roller *	
2	14		Cut & Tie Assembly	
	16		2.1 Base Assembly	
	18		2.2 Pressure Arm Assembly	
	20		2.3 Top Arm Assembly	
3	22		Tower Assembly	
	24		3.1 Tower Frame	
	26		3.2 Tower Motor Assembly	
	28		3.3 1120 Wrap Arm Drive	
	30		3.4 1120 Wrap Arm Drive	
	32		3.5 1120 Wrap Arm Mounting	
	34		3.6 1120 Dispenser Mounting	
	36		3.7 Safety Arm Assembly	
4	38		Dispenser Assembly	
	40		4.1 Dispenser Insert Assembly	
	42		4.2 Dispenser Complete Assembly	
5	44		Expert & Wizard Controller	
	46		5.1 Expert Controller	

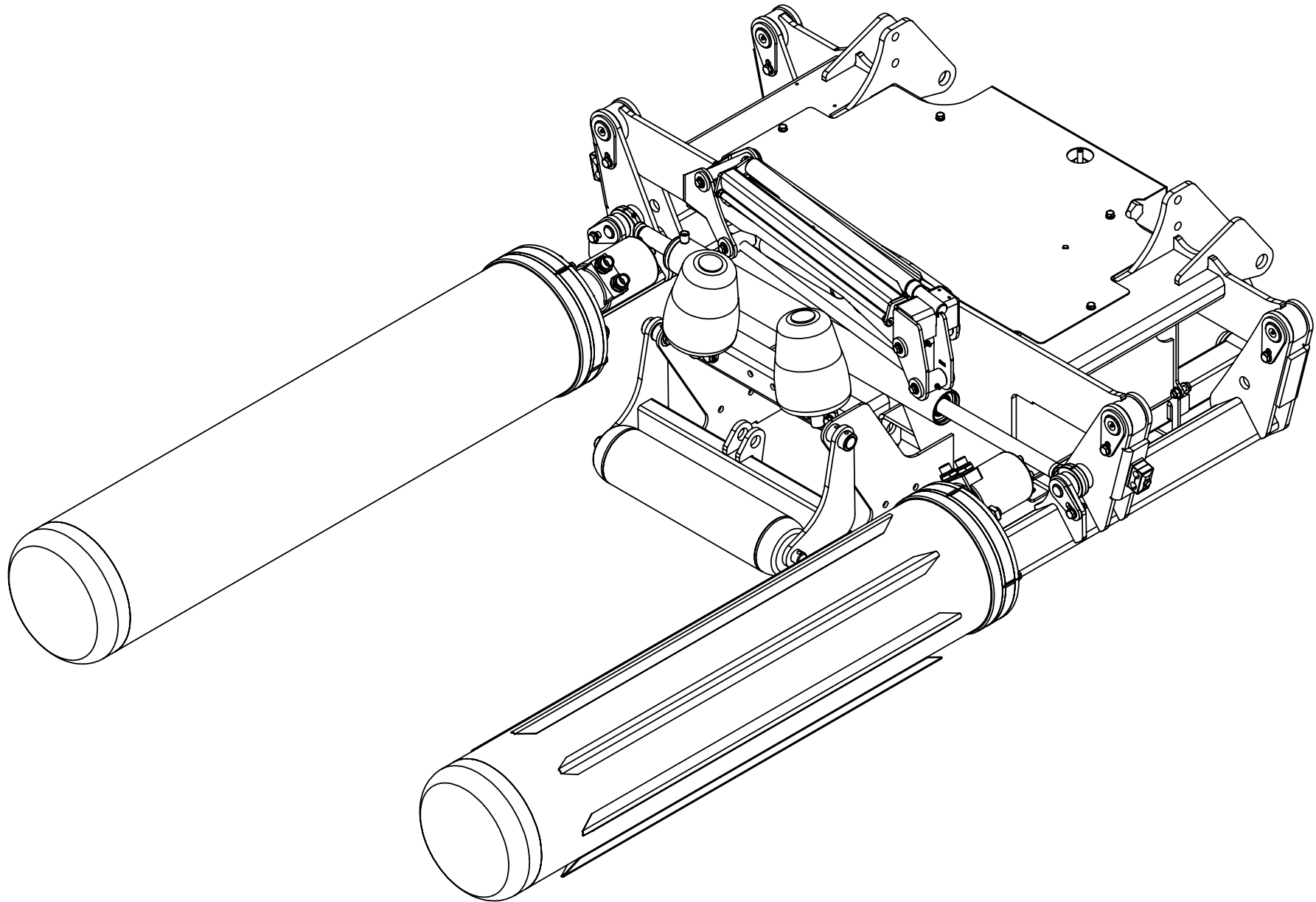

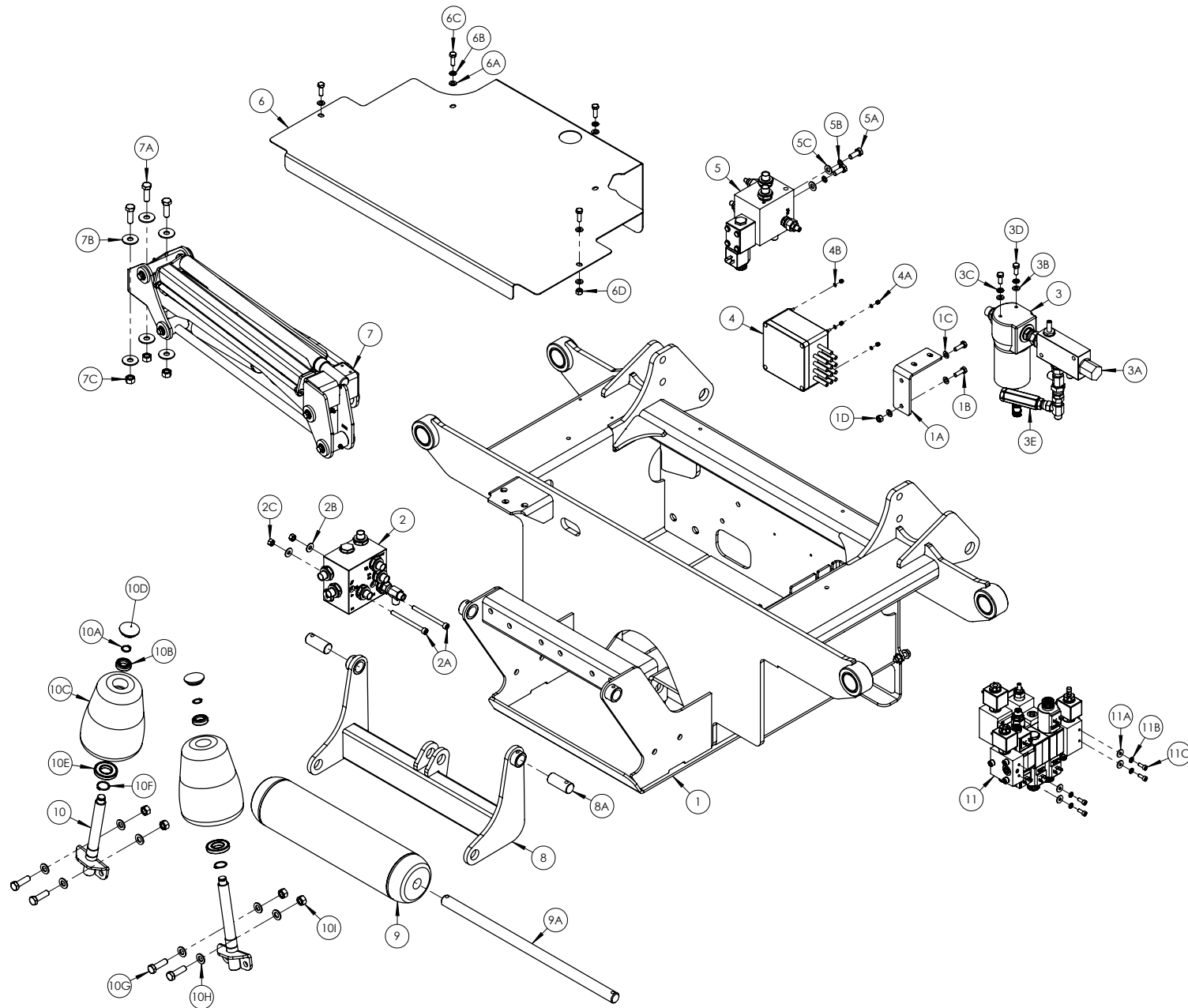

POS. NR. POS. NR. POS. NO.	TEILE NR. PART NR. PIECE NO.	STUCK QUANTITY QUANTITEE	BENENNUNG	DESCRIPTION	DESIGNATION	TECHNISCHE ANGABEN TECHNICAL DATA DONNEES TECHNIQUES
1	1311100	1		Chassis		
1A	1315106	1		Bracket		
1B	Z26-040B	2		Hex Bolt		M8 x 25mm
1C	Z10-02-08	3		Flat Washer		M8
1D	Z23-08	1		Locknut		M8
2	1308350	1		Assembly Block		
2A	Z13-6-08x100	2		Allen Head Bolt		M8 x 100mm
2B	Z11-02-081	2		Mud Washer		M8
2C	Z23-08	2		Locknut		M8
3	1308070	1		Oil Filter		
3A	Z01-03-10-A7W	1		Flow Regulator		1/2"
3B	Z10-02-08	2		Flat Washer		M8
3C	Z12-02-08	2		Spring Washer		M8
3D	Z26-040B	2		Hex Bolt		M8 x 25mm
4	1009001	1		Control Kit (Junction Box)		
4A	Z23-04	4		Locknut		M4
4B	Z10-02-04	4		Flat Washer		M4
5	1308180	1		Tower Block		
5A	Z26-0611S	2		Hex Set		M10 x 25mm
5B	Z12-02-08!	2		Spring Washer		M8
5C	Z10-02-10	2		Flat Washer		M10
6	1100120	1		Valve Cover		
6A	Z10-02-08	6		Flat Washer		M8
6B	Z12-02-08	2		Spring Washer		M8
6C	Z26-040B	4		Hex Set		M8 x 25mm
6D	Z23-08	2		Locknut		M8
7	1316100	1		Cut & Start Assembly		
7A	Z26-083S	3		Hex Set		M12 x 35mm
7B	Z11-02-121	6		Mud Washer		M12
7C	Z23-10	3		Locknut		M12
8	1100150	1		End Tip Frame		
8A	1100154	2		Cir Clip		
9	1100160	2		End Tip Roller		
9A	1100157	1		Roller Pin		
10	1403050	1		Bale Roller		
10A	34240713	2		Circlip		
10B	34320515	1		Bearing		
10C	34340106	2		Roller		
10D	Z32-15F	2		Plastic Cap		1 1/4"
10E	Bearing 25mm x 52mm	2		Bearing		25 x 52mm
10F	Z28-525	2		Circlip		
10G	Z26-084S	4		Hex Set		M12 x 40mm
11	1318050	1		Control Valve		

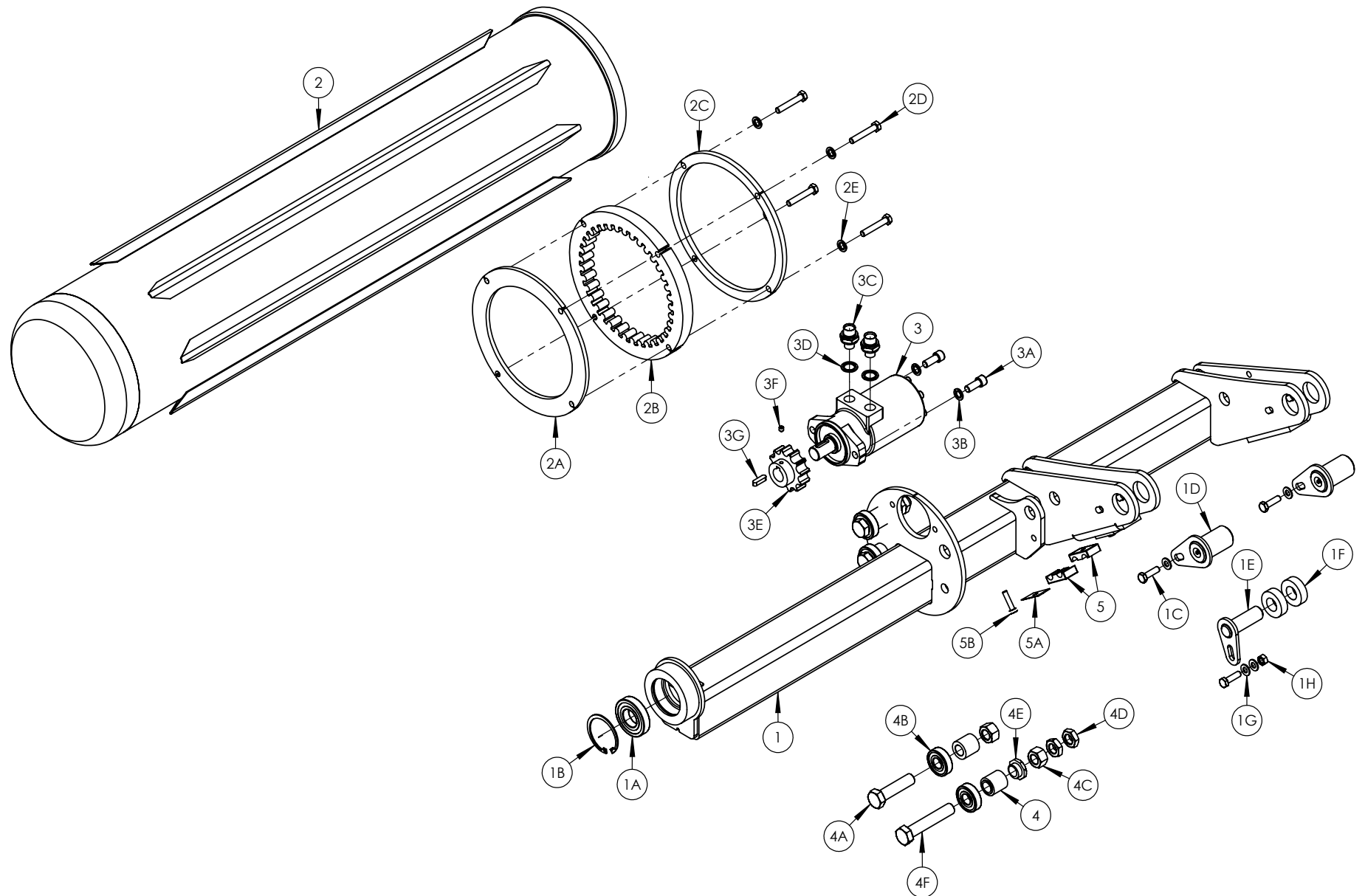

POS. NR.	TEILE NR.	STUCK	BENENNUNG	DESCRIPTION	DESIGNATION	TECHNISCHE ANGABEN
POS. NR.	PART NR.	QUANTITY				TECHNICAL DATA
POS. NO.	PIECE NO.	QUANTITEE				DONNEES TECHNIQUES
1	1112100	1		Roller Arm Frame Left		
1A	34240100	1		Cir Clip		
1B	34321521	1		Ball Bearing		
1C	Z26-063S	2		Pipe Clamp		15mm
1D	z01-24-28	1		Double Clamp Top		18mm
1E	Z26-042S	1		Hex Set		M8 x 35mm
2	34911048	1		Smooth Roller		
2A	34360519	1		Ring Roller Middle		
2B	34810044	1		Roller Sprocket		
2C	34360523	1		Ring Roller Shield		
2D	Z12-02-10	4		Spring Washer		M10
2E	Z26-067B	4		Hex Bolt		M10 x 60mm
3	1308802	1		Roller Drive Motor		
3A	Z13-6-12X30	2		Allen Head Bolt		M12 x 30mm
3B	Z12-02-12	2		Spring Washer		M12
3C	Z01-04-03	2		Dowty Washer		1/2"
3D	Z01-06-06-08	2		MM Adaptor		3/8" x 1/2" BSP
3E	34810042	1		Sprocket		12T (3/4")
3F	Z28-008	1		Grub Screw		M8 x 10mm
3G	34270111	1		Key Steel		8 x 7 x 30mm
4	34105718	4		Boss Bearing		
4A	Z26-1691B	2		Hex Bolt		M20 x 110mm
4B	34321529	4		Bearing		361204 R SKF
4C	34351006	2		Eccentric Boss		
4D	Z23-20	4		Locknut		M20
4E	34232901	4		Half Nut		M20
4F	Z26-167B	2		Hex Bolt		M20 X 80mm
5	1315102	2		Pivot Pin		
5A	Z26-063S	2		Hex Set		M10 x 35mm
5B	Z10-02-10	4		Flat Washer		M10
5C	Z23-10	2		Locknut		M10
6	1318170	1		Width Cylinder		
6A	1315104	1		Cylinder Pin		
6B	1315105	2		Width Ram Spacer		
6C	Z26-063S	1		Hex Set		M10 x 35mm
6D	Z10-02-10	2		Flat Washer		M10
6E	Z23-10	1		Locknut		M10
7	34911048	1		Smooth Roller		8 x 24mm x 19 Link
8	1315112	1		Alloy Chain		
8A	1315115	1		Chain Deflector		
8B	Z10-02-10	1		Flat Washer		M10
8C	Z26-063S	2		Hex Set		M10 x 35mm
8D	Z23-10	2		Locknut		M10



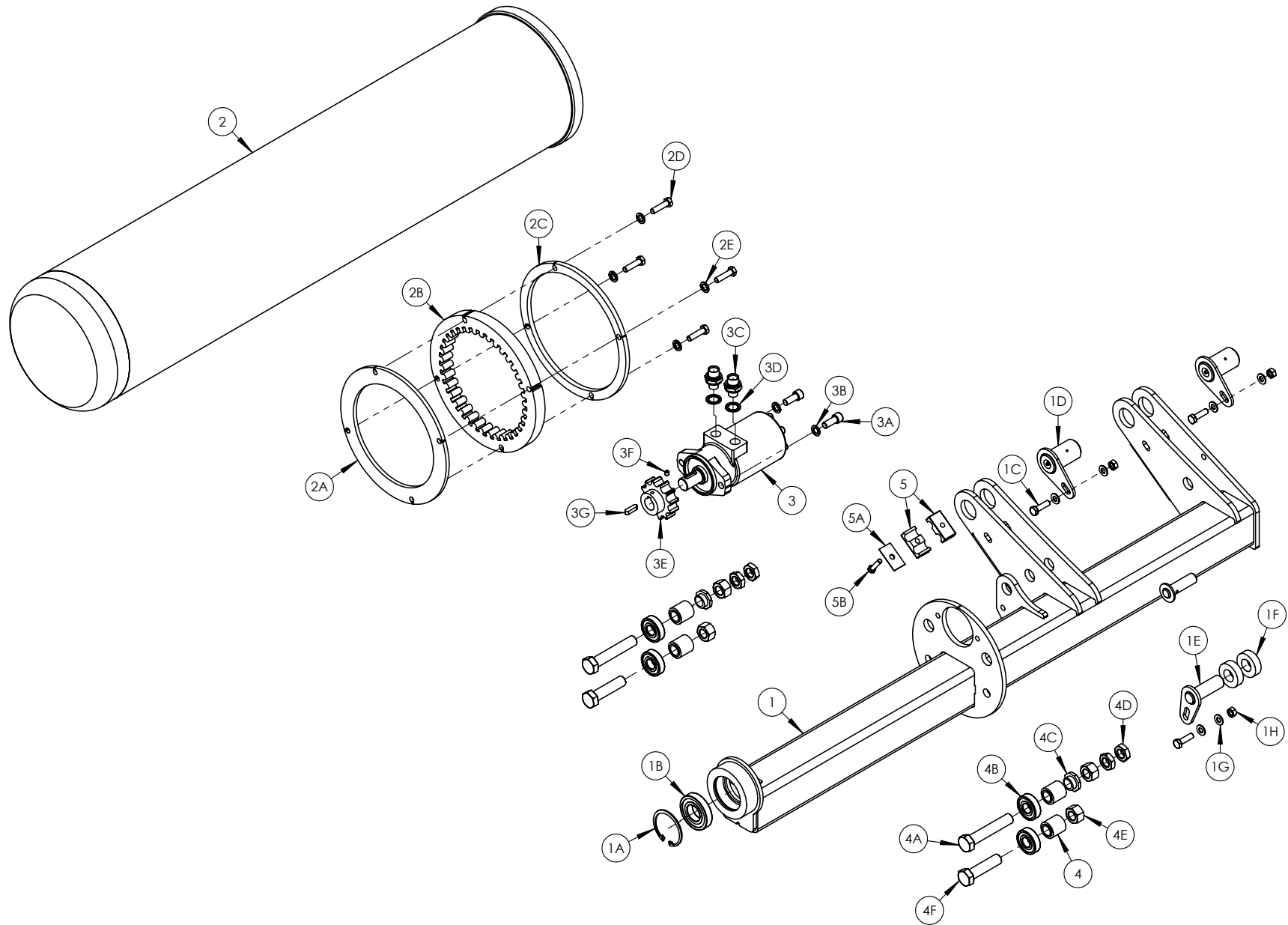

POS. NR.	TEILE NR.	STUCK	BENENNUNG	DESCRIPTION	DESIGNATION	TECHNISCHE ANGABEN
POS. NR.	PART NR.	QUANTITY				TECHNICAL DATA
POS. NO.	PIECE NO.	QUANTITEE				DONNEES TECHNIQUES
1	1112200	1		Roller Arm Frame Right		
1A	34240100	1		Cir Clip		
1B	34321521	1		Ball Bearing		
1C	Z26-063S	2		Pipe Clamp		15mm
1D	z01-24-28	1		Double Clamp Top		18mm
1E	Z26-042S	1		Hex Set		M8 x 35mm
2	34911049	1		Gripped Roller		
2A	34360519	1		Ring Roller Middle		
2B	34810044	1		Roller Sprocket		
2C	34360523	1		Ring Roller Shield		
2D	Z12-02-10	4		Spring Washer		M10
2E	Z26-067B	4		Hex Bolt		M10 x 60mm
3	1308802	1		Roller Drive Motor		
3A	Z13-6-12X30	2		Allen Head Bolt		M12 x 30mm
3B	Z12-02-12	2		Spring Washer		M12
3C	Z01-04-03	2		Dowty Washer		1/2"
3D	Z01-06-06-08	2		MM Adaptor		3/8" x 1/2" BSP
3E	34810042	1		Sprocket		12T (3/4")
3F	Z28-008	1		Grub Screw		M8 x 10mm
3G	34270111	1		Key Steel		8 x 7 x 30mm
4	34105718	4		Boss Bearing		
4A	Z26-1691B	2		Hex Bolt		M20 x 110mm
4B	34321529	4		Bearing		361204 R SKF
4C	34351006	2		Eccentric Boss		
4D	Z23-20	4		Locknut		M20
4E	34232901	4		Half Nut		M20
4F	Z26-167B	2		Hex Bolt		M20 X 80mm
5	1315102	2		Pivot Pin		
5A	Z26-063S	2		Hex Set		M10 x 35mm
5B	Z10-02-10	4		Flat Washer		M10
5C	Z23-10	2		Locknut		M10
6	1318170	1		Width Cylinder		
6A	1315104	1		Cylinder Pin		
6B	1315105	2		Width Ram Spacer		
6C	Z26-063S	1		Hex Set		M10 x 35mm
6D	Z10-02-10	2		Flat Washer		M10
6E	Z23-10	1		Locknut		M10
7	34911048	1		Smooth Roller		8 x 24mm x 19 Link
8	1315112	1		Alloy Chain		
8A	1315115	1		Chain Deflector		
8B	Z10-02-10	1		Flat Washer		M10
8C	Z26-063S	2		Hex Set		M10 x 35mm
8D	Z23-10	2		Locknut		M10

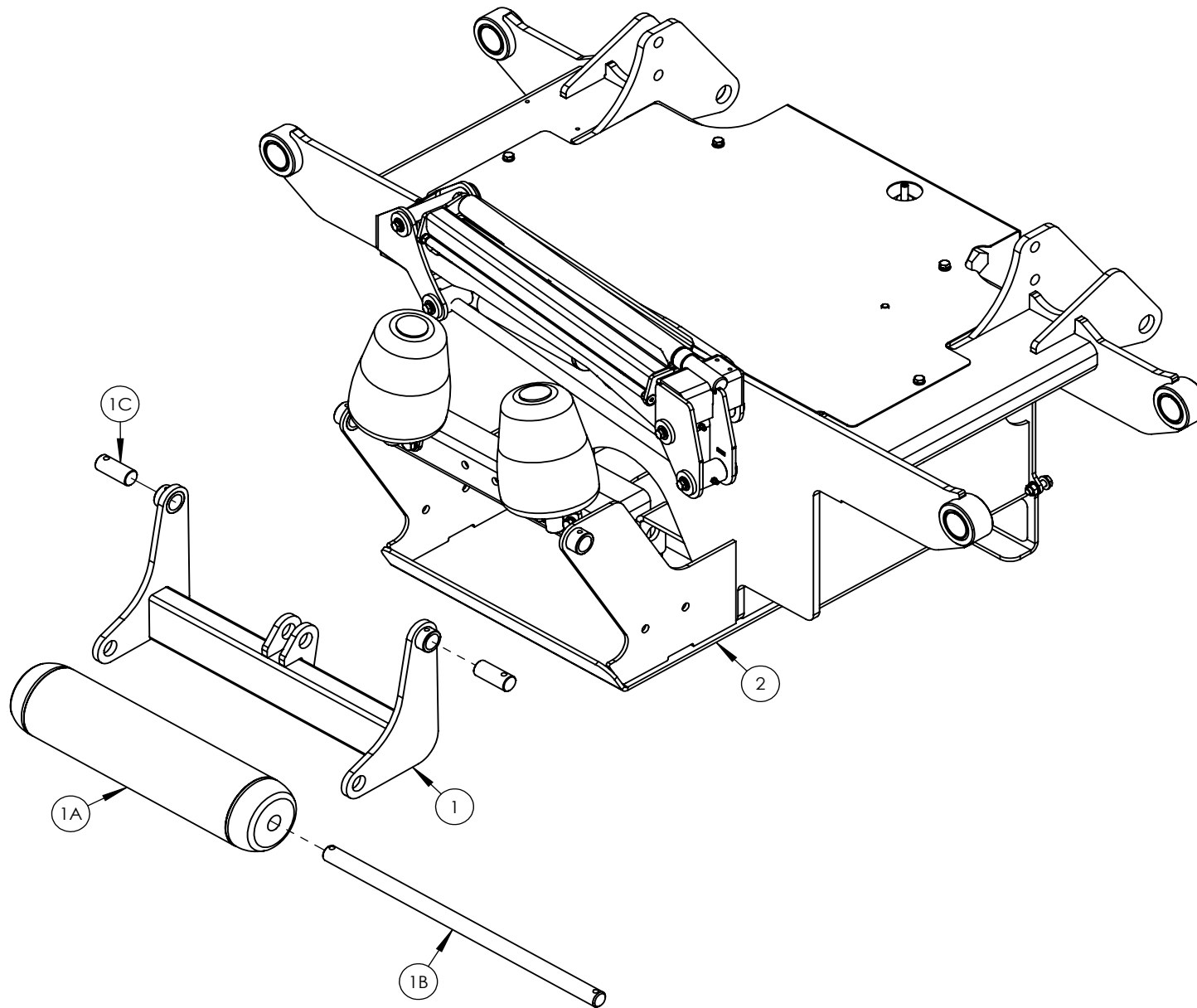

POS. NR.	TEILE NR.	STUCK	BENENNUNG	DESCRIPTION	DESIGNATION	TECHNISCHE ANGABEN
POS. NR.	PART NR.	QUANTITY				TECHNICAL DATA
POS. NO.	PIECE NO.	QUANTITEE				DONNEES TECHNIQUES
1	1100150	1		Pusher Frame		
1A	1100160	1		End Tip Roller		
1B	1100157	1		Roller Pin		
1C	1100154	1		Cylinder Pin		
2	1100100	1		Chassis Frame		

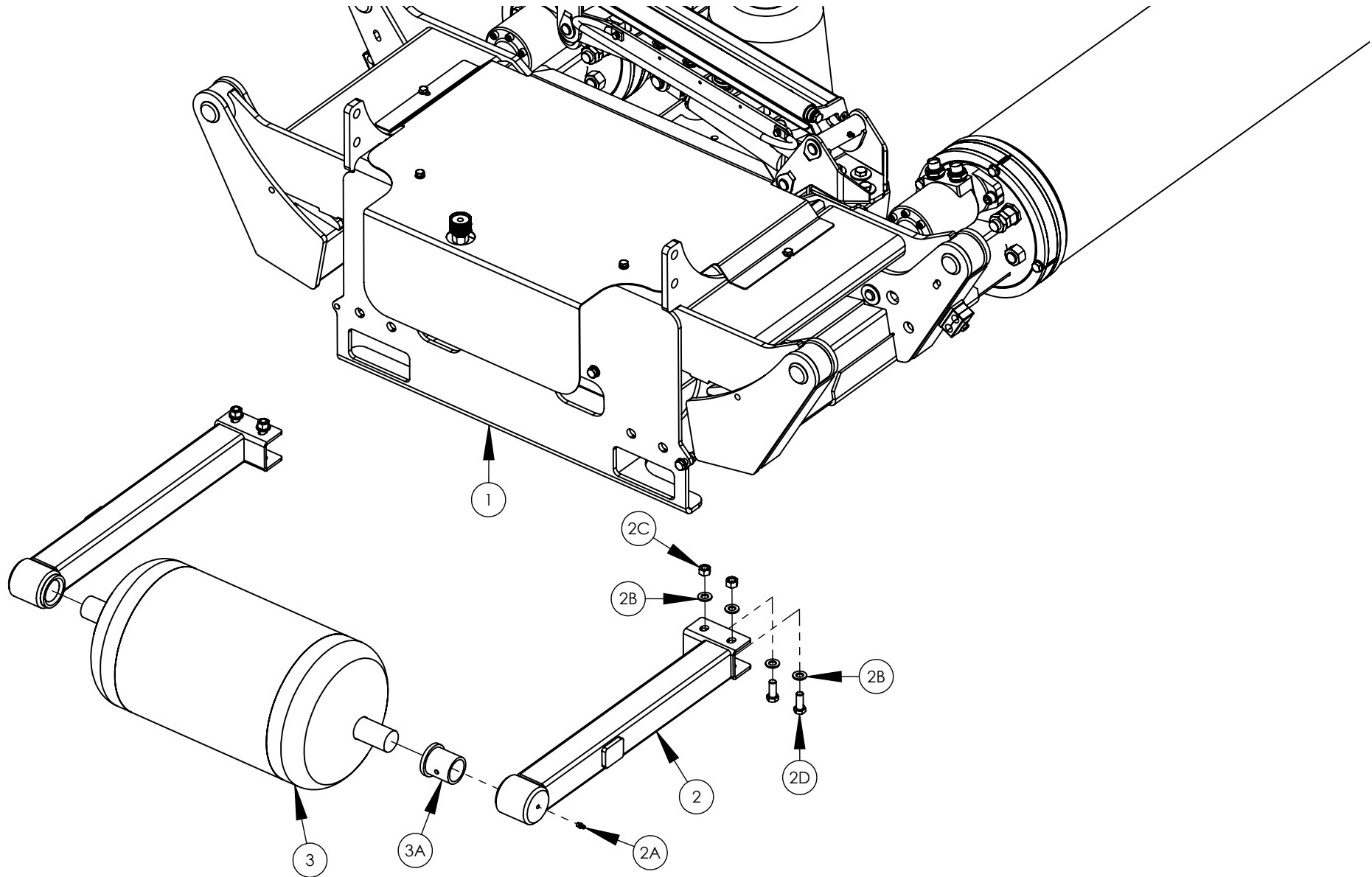

POS. NR.	TEILE NR.	STUCK	BENENNUNG	DESCRIPTION	DESIGNATION	TECHNISCHE ANGABEN
POS. NR.	PART NR.	QUANTITY				TECHNICAL DATA
POS. NO.	PIECE NO.	QUANTITEE				DONNEES TECHNIQUES
1	1311100	1		Chassis		
2	1311065	2		Roller Mounting Bracket		
2A	34060800	2		Grease Nipple		M8
2B	Z10-02-12	8		Flat Washer		M12
2C	Z23-12	4		Locknut		M12
2D	Z26-082S	4		Hex Set		M12 x 30mm
3	1501585	1		Ground Roller		
3A	34360503	2		Roller Bush		

Tanco Autowrap - 1120

Ersatzteilliste / Spare Parts Manual / Liste des pièces de rechange



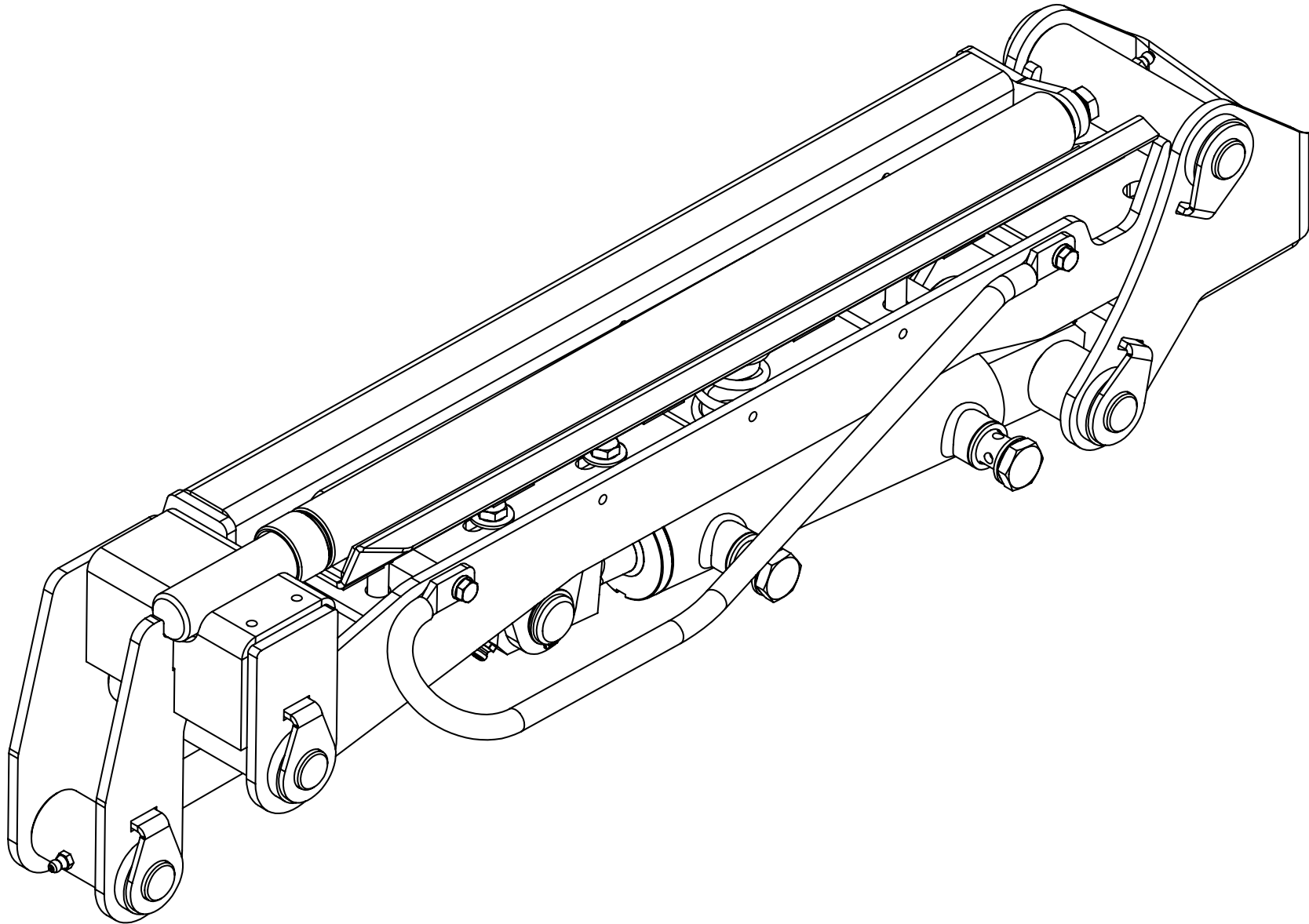

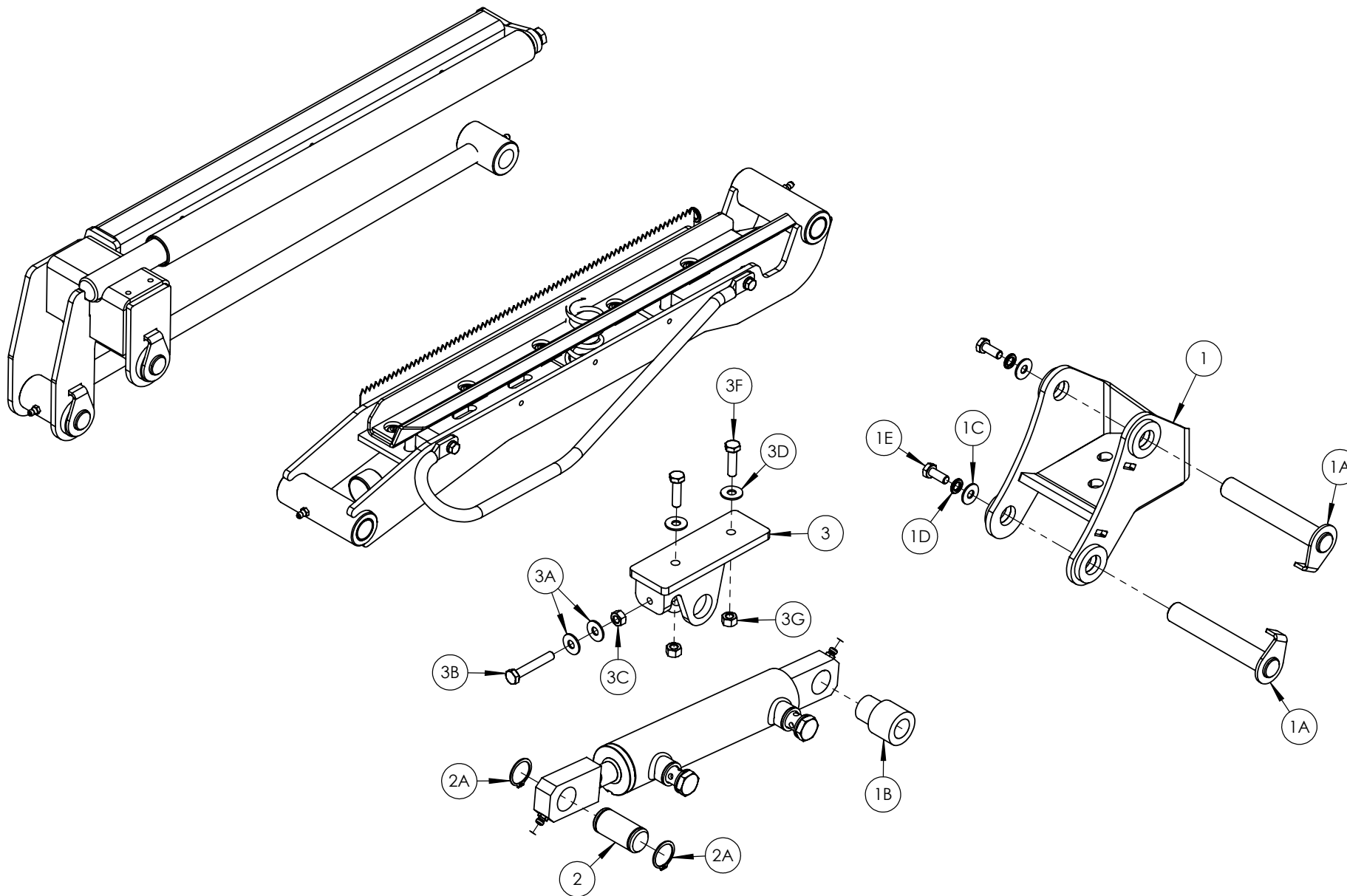

POS. NR. POS. NR. POS. NO.	TEILE NR. PART NR. PIECE NO.	STUCK QUANTITY QUANTITEE	BENENNUNG	DESCRIPTION	DESIGNATION	TECHNISCHE ANGABEN TECHNICAL DATA DONNEES TECHNIQUES
1	1316010	1		Cut & Tie Base		
1A	1406080	2		Pivot Pin (Long)		
1B	1406035	1		Spacer		
1C	Z11-02-081	2		Mud Washer		M8
1D	Z12-02-08	2		Spring Washer		M8
1E	Z26-039S	2		Hex Set		M8 x 20mm
2	1308151	1		Cylinder		
2A	34060800	2		Grease Nipple		M8 x 1.25
2B	34105631	1		Cylinder Pin		
2C	Z28-525	2		Circlip		M25 Ext.
3	34920525	1		Cylinder Adjuster		
3A	Z11-02-081	2		Mud Washer		M8
3B	Z26-045S	1		Hex Set		M8 x 50mm
3C	Z18-08	1		Plain Hex Nut		M8
3D	Z11-02-081	2		Mud Washer		M8
3E	Z26-041S	2		Hex Set		M8 x 30mm
3F	Z23-08	2		Hex Nut		M8

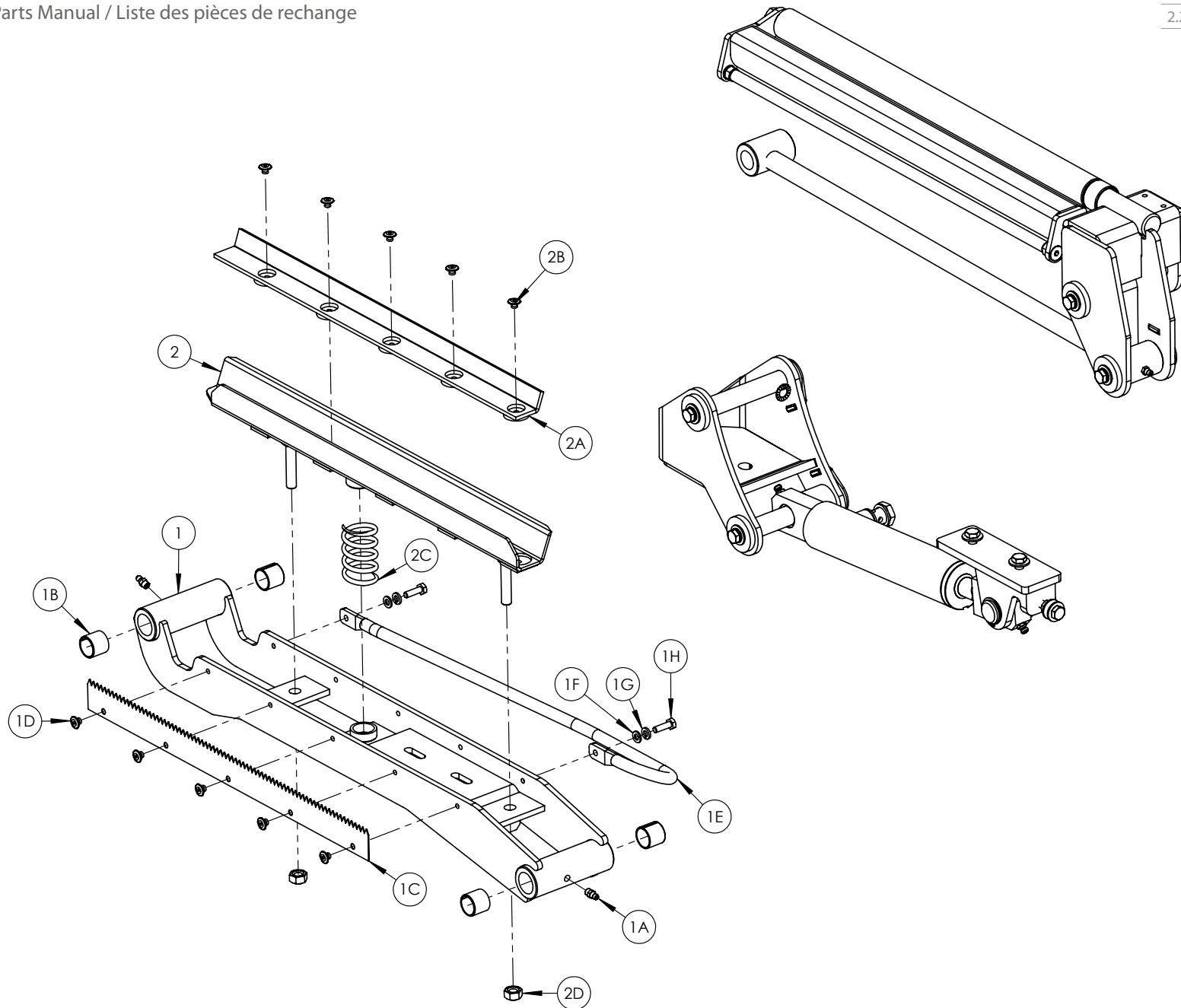

POS. NR.	TEILE NR.	STUCK	BENENNUNG	DESCRIPTION	DESIGNATION	TECHNISCHE ANGABEN
POS. NR.	PART NR.	QUANTITY				TECHNICAL DATA
POS. NO.	PIECE NO.	QUANTITEE				DONNEES TECHNIQUES
1	1406112	1		Lift Arm		
1A	34060800	2		Grease Nipple		M8 x 1.25
1B	1406074	1		Blade		
1C	Z03-25-05	5		Pop Rivet		4.8 x 16mm
1D	1406075	1		Film Gathering Bar		
1E	Z10-02-06	2		Flat Washer		M6
1F	Z12-02-06	2		Spring Washer		M6
1G	Z26-020S	2		Hex Set		M6 x 20mm
2	1406101	1		Pressure Plate		
2A	1406706	1		Rubber Strip		
2B	Z03-25-05	5		Pop Rivet		4.8 x 16mm
2C	1406078	1		Pressure Spring		
2D	Z23-10	2		Locknut		M10

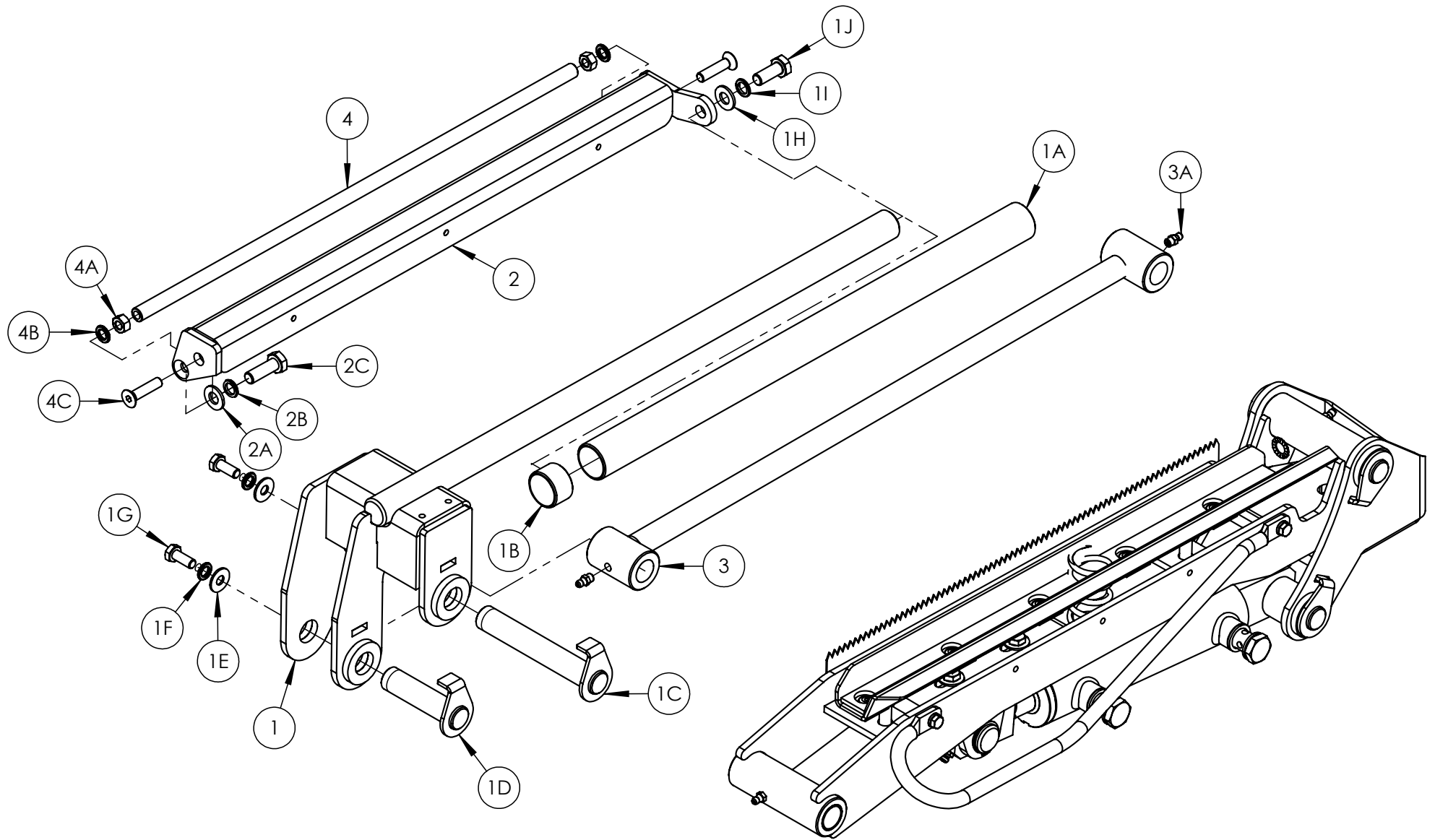

POS. NR. POS. NR. POS. NO.	TEILE NR. PART NR. PIECE NO.	STUCK QUANTITY QUANTITEE	BENENNUNG	DESCRIPTION	DESIGNATION	TECHNISCHE ANGABEN TECHNICAL DATA DONNEES TECHNIQUES
1	1406113	1		Pull Down Arm		
1A	1406077	1		Knurled Roller		
1B	1406085	1		Pivot Pin (Short)		
1C	1406080	1		Pivot Pin (Long)		
1D	Z11-02-081	2		Mud Washer		M8
1E	Z12-02-08	2		Spring Washer		M8
1F	Z26-039S	2		Hex Set		M8 x 20mm
1G	Z10-02-10	1		Flat Washer		M10
1H	Z12-02-10	1		Spring Washer		M10
1I	Z26-0611S	1		Hex Set		M10 x 25mm
2	1406065	1		Top Arm		
2A	Z10-02-08	2		Flat Washer		M8
2B	Z12-02-08	2		Spring Washer		M8
2C	Z18-08	1		Plain Hex Nut		M8
2D	Z26-041S	1		Hex Set		M8 x 30mm
3	1406102	1		Connecting Arm		
3A	34060800	2		Grease Nipple		M8 x 1.25
4	1406068	1		Film Roller		
4A	Z18-08	2		Plain Hex Nut		M8
4B	Z12-02-08	2		Spring Washer		M8
4C	Z13-5-08X35	2		Countersunk Allen Head Set		M8 x 35mm

Tanco Autowrap - 1120

Ersatzteilliste / Spare Parts Manual / Liste des pièces de rechange



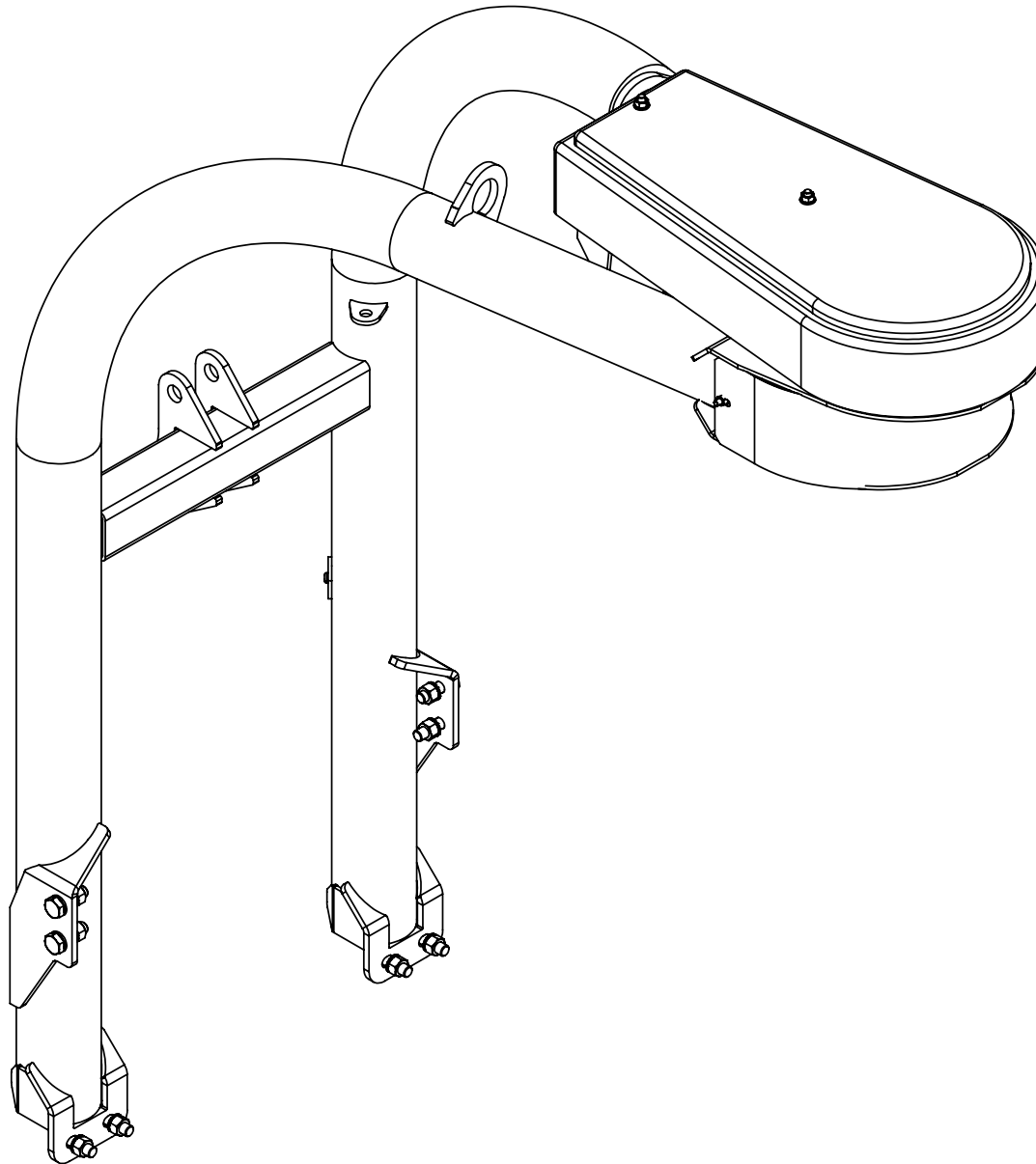

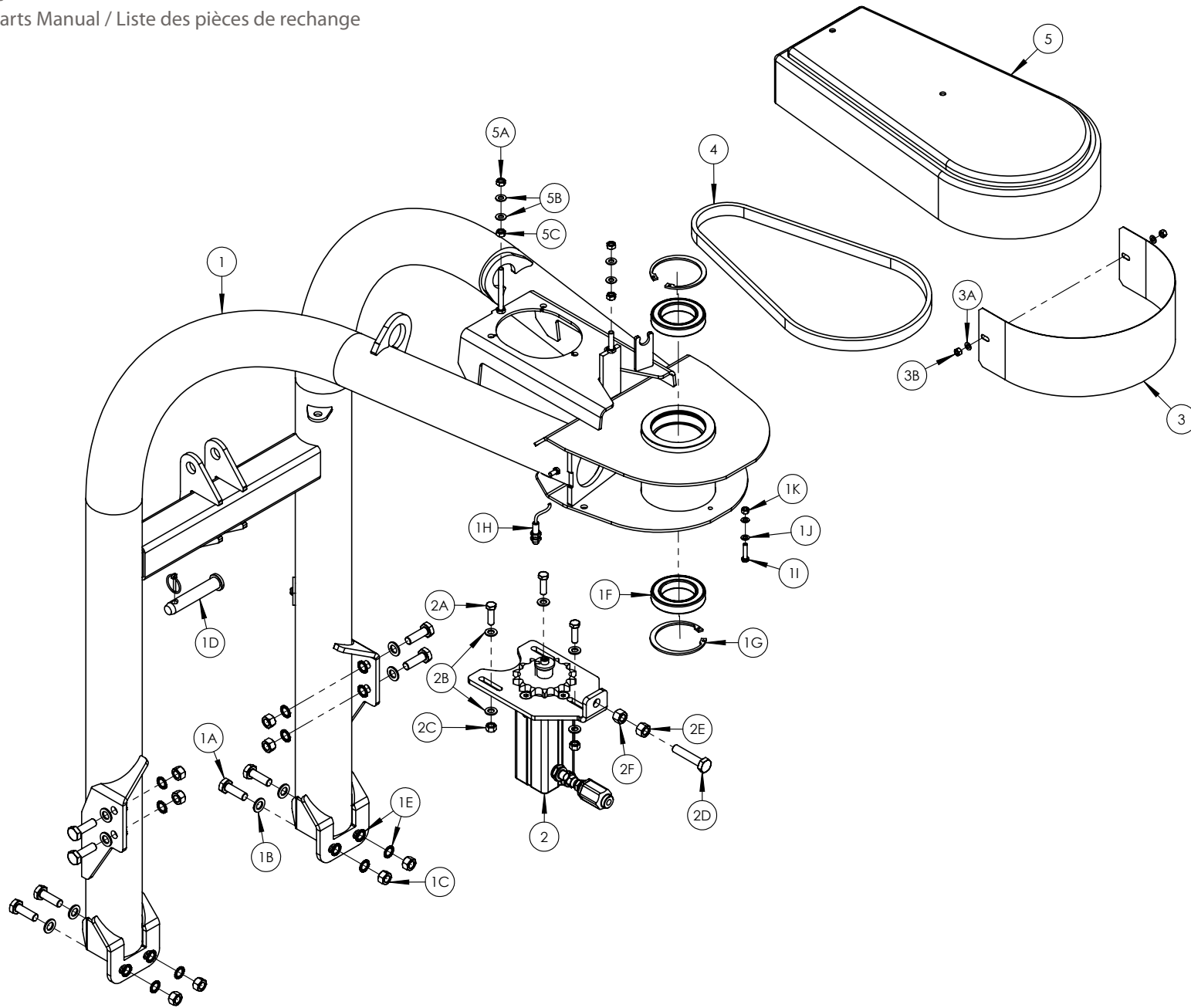

POS. NR. POS. NR. POS. NO.	TEILE NR. PART NR. PIECE NO.	STUCK QUANTITY QUANTITEE	BENENNUNG	DESCRIPTION	DESIGNATION	TECHNISCHE ANGABEN TECHNICAL DATA DONNEES TECHNIQUES
1	1113100	1		Tower Frame		
1A	Z31B-064	8		Hex Set		M16 x 45mm
1B	Z10-02-16	8		Flat Washer		M16
1C	Z20-10	8		Locknut		M16
1D	34105635	1		Top Link Pin		
1E	Serrated Lock Washer 1 _ DIN	16		Serrated Lock Washer		17mm
1F	1404052	2		Bearing		6014 2RS
1G	1404051	2		Circlip		Int. 110mm
1H	1309203	1		RDS Sensor		
1I	Z26-042S	1		Hex Set		M8 x 35mm
1J	Z10-02-08	2		Flat Washer		M6
1K	Z23-08	1		Locknut		M6
2	Z01-02-RF200	1		Tower Motor		
2A	Z26-084S	3		Hex Set		M12 x 35mm
2B	Z10-02-12	6		Flat Washer		M12
2C	Z23-12	3		Locknut		M12
2D	Z26-12915	1		Hex Set		M16 x 80
2E	Z18-16	1		Plain Hex Nut		M16
2F	Z23-16	1		Locknut		M16
3	1404076	1		Tower Front Cover		
3A	Z10-02-08	2		Flat Washer		M8
3B	Z23-08	2		Locknut		M8 x 20mm
4	Z09-AW9	1		1" BS Chain (56 Links)		1" 56 Links
5	1404450	1		Chain Cover		
5A	Z23-10	2		Locknut		M10
5B	Z10-02-10	4		Flat Washer		M10
5C	Z18-10	2		Plain Hex Nut		M10

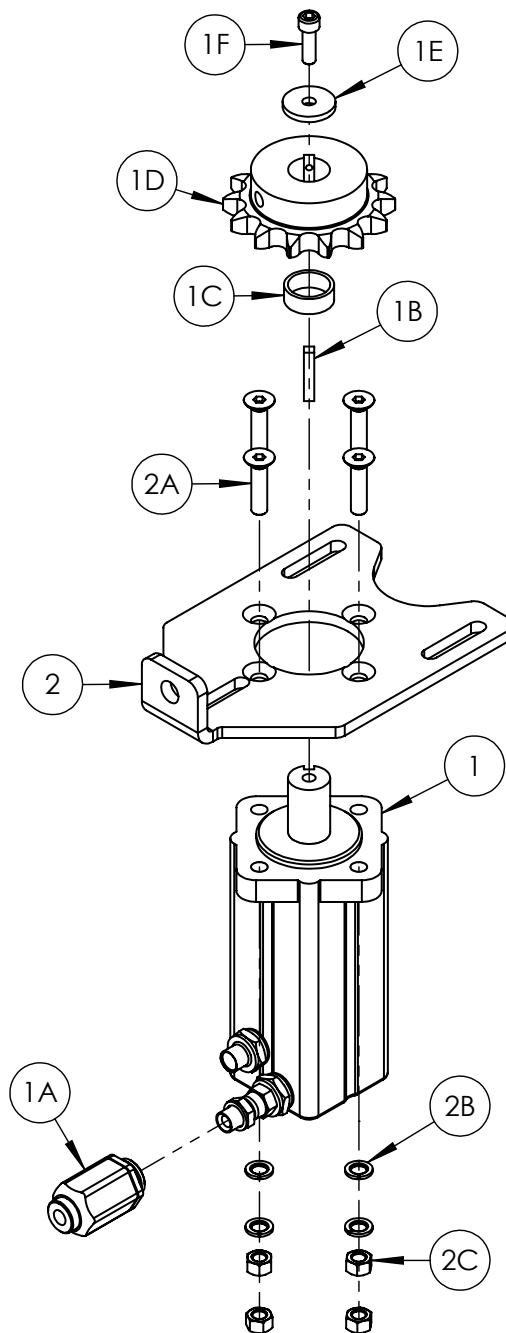

POS. NR.	TEILE NR.	STUCK	BENENNUNG	DESCRIPTION	DESIGNATION	TECHNISCHE ANGABEN
POS. NR.	PART NR.	QUANTITY				TECHNICAL DATA
POS. NO.	PIECE NO.	QUANTITEE				DONNEES TECHNIQUES
1	Z01-02-RF200	1		Tower Motor		
1A	Z01-03-1046	1		Speed Control Valve		3/8"
1B	WD64-053			Key Steel		5/16" x 5/16" x 45mm
1C	1503172	1		Motor Spacer		
1D	1315301	1		Sprocket		1" x 14T
1E	WD623-071	1		Collar		
1F	Z13-4-32	1		UNC Socket Cap Screw		1 1/4" x 3/8"
2	1503247	1		Motor Mounting Plate		
2A	Z13-5-12X50	4		Countersunk Allen Head Set		M12 x 50mm
2B	Z12-02-12	4		Spring Washer		M12
2C	Z23-12	4		Locknut		M12

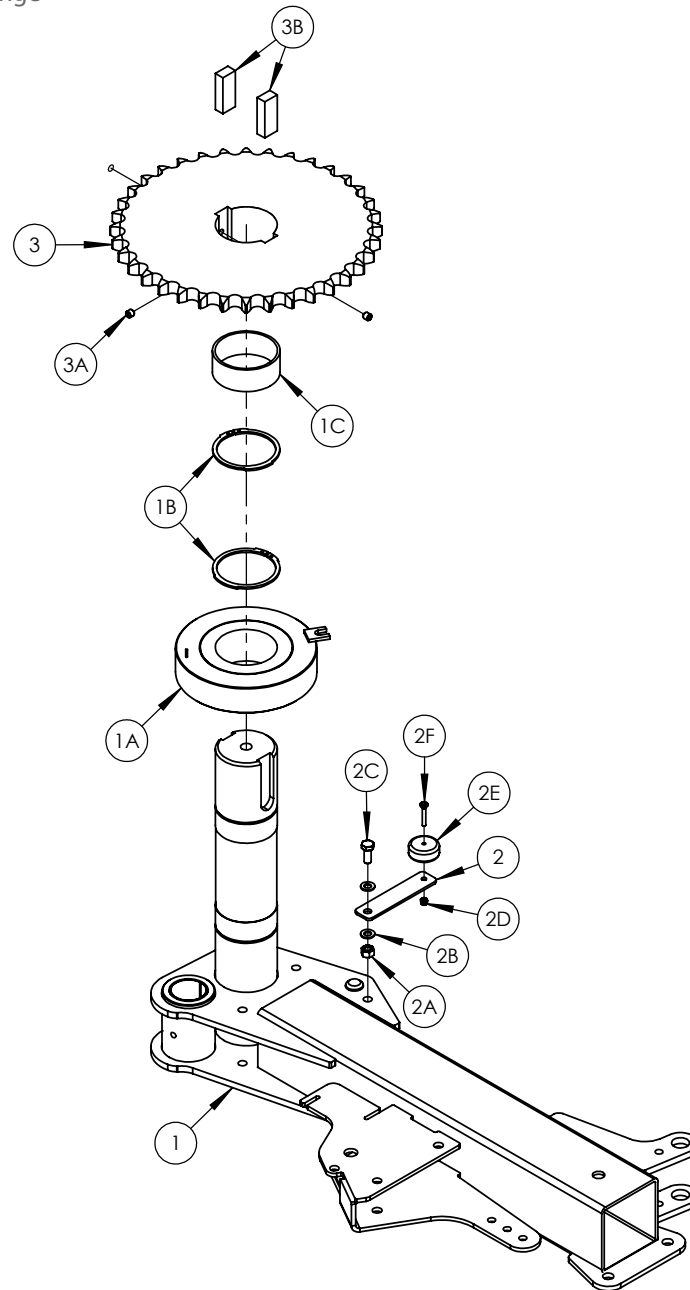

POS. NR. POS. NR. POS. NO.	TEILE NR. PART NR. PIECE NO.	STUCK QUANTITY QUANTITEE	BENENNUNG	DESCRIPTION	DESIGNATION	TECHNISCHE ANGABEN TECHNICAL DATA DONNEES TECHNIQUES
1	1114100	1		Main Wrap Arm Mounting		
1A	1319100	1		Slew Ring		
1B	1404053	2		Circlip		Ext. 67mm
1C	1403075	1		Spacer		
2	1315109	1		Magnet Bracket		
2A	Z23-08	1		Locknut		M8 x 20mm
2B	Z10-02-08	2		Flat Washer		8mm
2C	Z26-039S	1		Hex Set		M8 x 20mm
2D	Z23-04	1		Locknut		M4
2E	1309201	1		RDS Magnet		
2F	Z13-5-04X30	1		Countersunk Allen Head Set		M4 x 30mm
3	1404010	1		Sprocket		1" x 36T
3A	Z18-008	3		Grub Screw		M8 x 10mm
3B	1404024	2		Key Steel		20 x 12 x 50mm

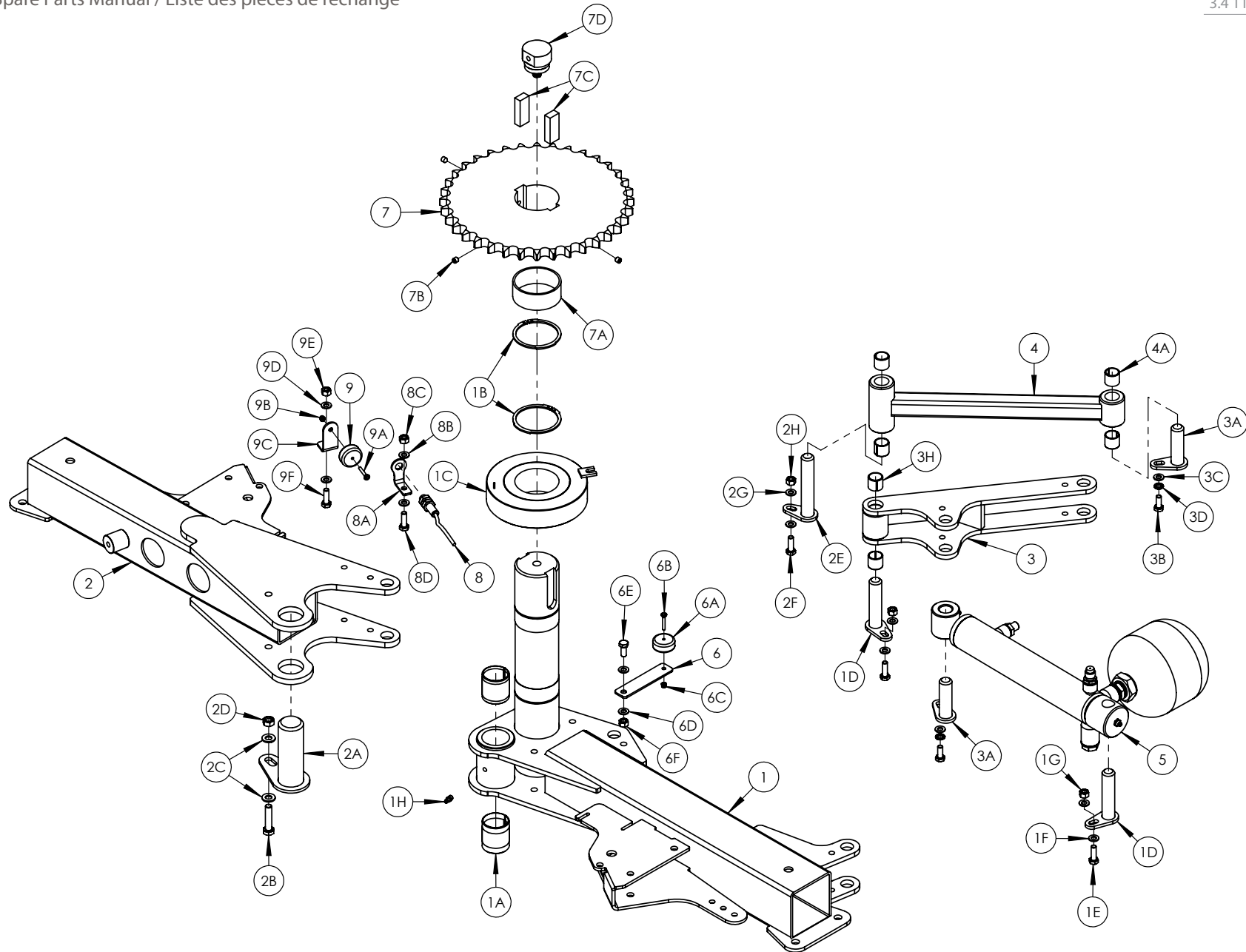

POS. NR.	TEILE NR.	STUCK	BENENNUNG	DESCRIPTION	DESIGNATION	TECHNISCHE ANGABEN
POS. NR.	PART NR.	QUANTITY				TECHNICAL DATA
POS. NO.	PIECE NO.	QUANTITEE				DONNEES TECHNIQUES
1	1114100	1		Main Wrap Arm Mounting		
1A	Z03-20-27	1		DX Bush		40mm ID x 40mm
1B	1404053	2		Circlip		Ext. 67mm
1C	1319100	1		Slew Ring		
1D	1315405	1		Cylinder Pin		
1E	Z26-040B	1		Hex Bolt		M8 x 25mm
1F	Z10-02-08	2		Flat Washer		M8
1G	Z23-08	1		Locknut		M8
1H	34060800	1		Grease Nipple		M8 x 1.25
2	1114200	1		Slave Wrap Arm Mounting		
2A	1315409	1		Pivot Pin		
2B	Hex Bolt GradeAB BSI	1		Hex Bolt		M10 x 30mm
2C	1303004	2		Flat Washer		M10
2D	Z23-10	1		Locknut		M10
2E	1315403	1		Lnkage Pin		
2F	Z26-040B	1		Hex Bolt		M8 x 25mm
2G	Z10-02-08	2		Flat Washer		M8
2H	Z23-08	1		Locknut		M8
3	1314400	1		Fixed Linkage Assembly		
3A	1315407	1		Cylinder Pin		
3B	Z26-039S	1		Hex Bolt		M8 x 20mm
3C	Z10-02-08	1		Flat Washer		M8
3D	Z12-02-08	1		Spring Washer		M8
3E	Z26-040B	1		Hex Bolt		M8 x 25mm
3F	Z10-02-08	1		Flat Washer		M8
3G	Z23-08	1		Locknut		M8
3H	z03-20-32	1		DX Bush		20mm ID x 20mm
4	1314300	1		Linkage Assembly		
4A	Z03-20-32	2		DX Bush		20mm ID x 20mm
4B	34060800	1		Grease Nipple		M8 x 1.25
5	1318171	1		Folding Cylinder		
6	1315109	1		Magnet Bracket		
6A	1309201	1		RDS Magnet		
6B	Z13-5-04X30	1		Countersunk Allen Head Set		M4 x 30mm
6C	Z23-04	1		Locknut		M4
6D	Z10-02-08	2		Flat Washer		8mm
6E	Z26-039S	1		Hex Set		M8 x 20mm
6F	Z23-08	1		Locknut		M8 x 20mm
7	1404010	1		Sprocket		1" x 36T
7A	1403075	1		Spacer		
7B	Z18-008	3		Grub Screw		M8 x 10mm
7C	1404024	2		Key Steel		20 x 12 x 50mm
7D	1318176	1		Rotary Coupling		
8	Sensor	1		Sensor Assembly		
8A	1315116	1		Sensor Bracket		
8B	Z10-02-08	2		Flat Washer		M8
8C	Z23-08	1		Locknut		M8
8D	Z26-040B	1		Hex Bolt		M8 x 25mm
9	1309201	1		Magnet		
9A	Z13-5-04X30	1		Countersunk Allen Head Set		M4 x 30mm
9B	Z23-04	1		Locknut		M4
9C	1315117	1		Magnet Bracket		
9D	Z10-02-08	2		Flat Washer		M8
9E	Z23-08	1		Locknut		M8
9F	Z26-040B	1		Hex Bolt		M8 x 25mm

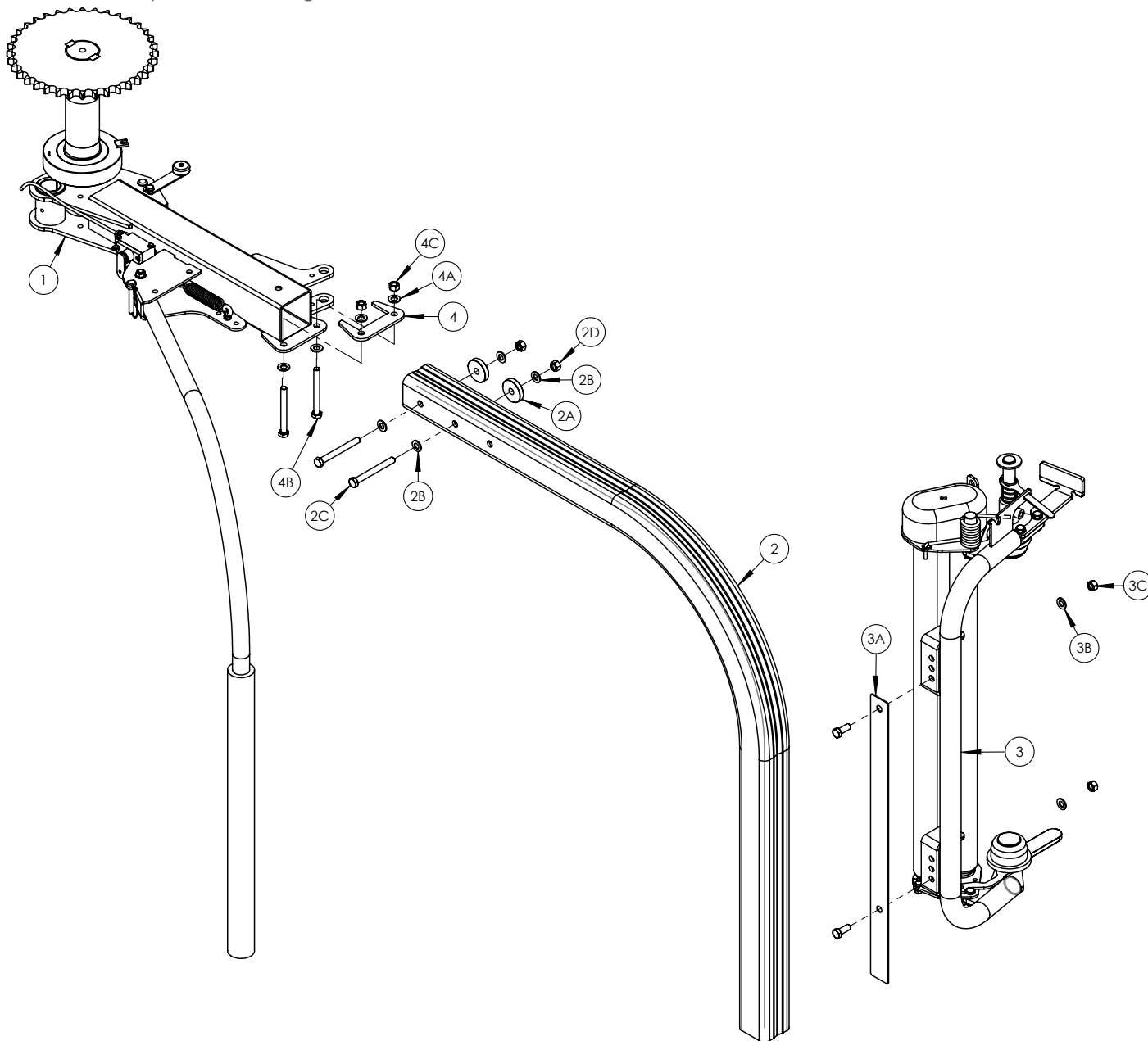

POS. NR.	TEILE NR.	STUCK	BENENNUNG	DESCRIPTION	DESIGNATION	TECHNISCHE ANGABEN
POS. NR.	PART NR.	QUANTITY				TECHNICAL DATA
POS. NO.	PIECE NO.	QUANTITEE				DONNEES TECHNIQUES
1	1114100	1		Main Rotating Arm		
1A	Z26-082S	1		Hex Set		M12 x 30mm
2	1404009	2		Wrap Arm		
2A	1314013	2		Washer		50mm OD x M12 ID
2B	Z10-02-12	4		Flat Washer		M12
2C	Z26-093B	2		Hex Set		M12 x 110mm
2D	Z23-12	2		Locknut		M12
3	1314610	1		Standard Dispenser Assembly		
3A	1405015	1		Dispenser Mounting Bracket		
3B	Z10-02-12	6		Flat Washer		M10
3C	Z23-12	3		Locknut		M12
4	1314015	1		Clamping Plate		
4A	Z10-02-12	4		Flat Washer		M12
4B	Z26-093B	2		Hex Set		M12 x 110mm
4C	Z23-12	2		Locknut		M12

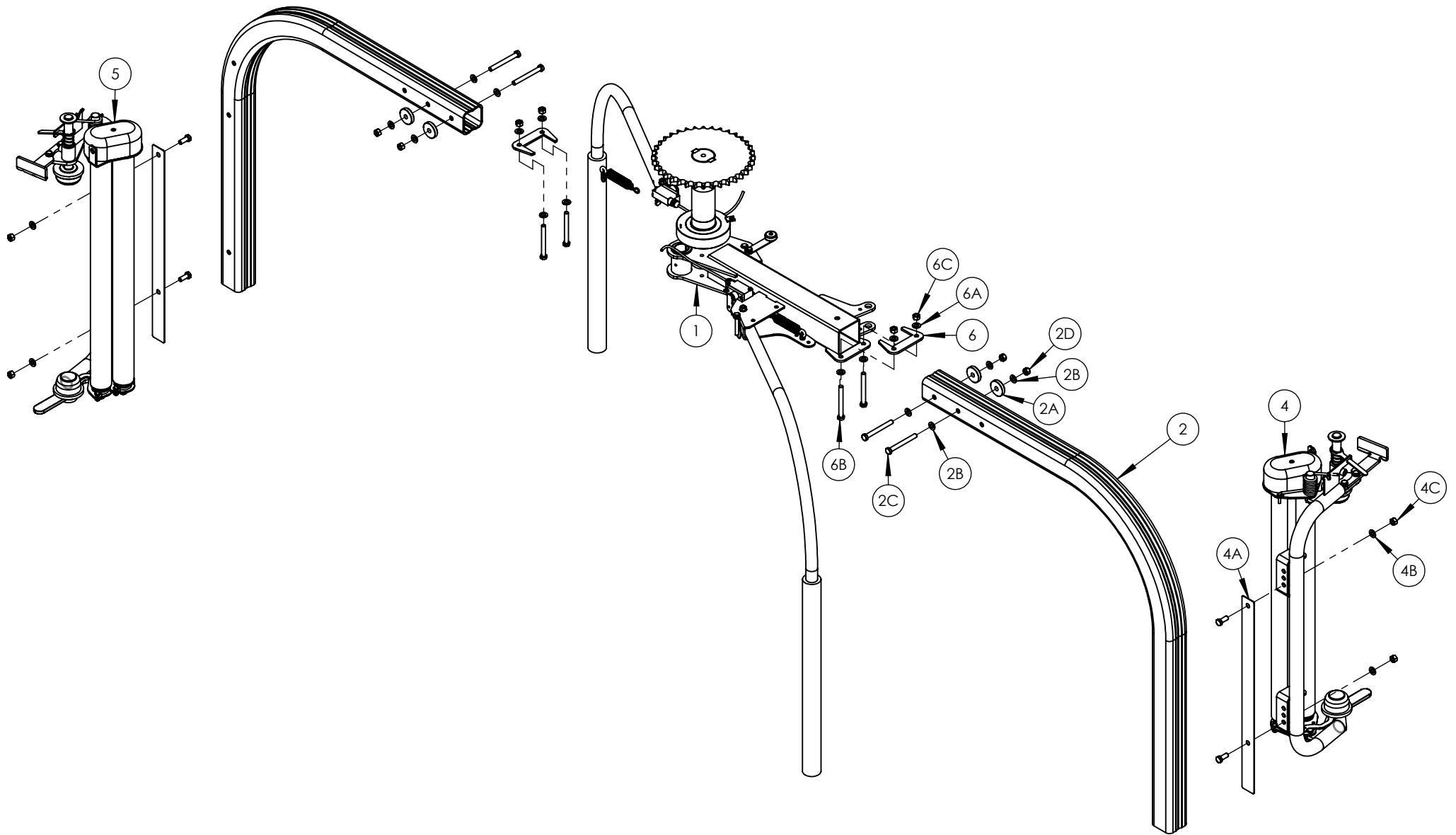

POS. NR. POS. NR. POS. NO.	TEILE NR. PART NR. PIECE NO.	STUCK QUANTITY QUANTITEE	BENENNUNG	DESCRIPTION	DESIGNATION	TECHNISCHE ANGABEN TECHNICAL DATA DONNEES TECHNIQUES
1	1114100	1		Main Rotating Arm		
1A	Z26-082S	1		Hex Set		M12 x 30mm
2	1404009	2		Wrap Arm		
2A	1314013	2		Washer		50mm OD x M12 ID
2B	Z10-02-12	4		Flat Washer		M12
2C	Z26-093B	2		Hex Set		M12 x 110mm
2D	Z23-12	2		Locknut		M12
3	1314200	1		Slave Rotating Arm		
3A	Z10-28	1		Rubber Buffer		50 x 30mm
4	1314610	1		Standard Dispenser Assembly		
4A	1405015	1		Dispenser Mounting Bracket		
4B	Z10-02-12	6		Flat Washer		M10
4C	Z23-12	3		Locknut		M12
5	1314510	1		Slave Dispenser Assembly		
6	1314015	1		Clamping Plate		
6A	Z10-02-12	4		Flat Washer		M12
6B	Z26-093B	2		Hex Set		M12 x 110mm
6C	Z23-12	2		Locknut		M12

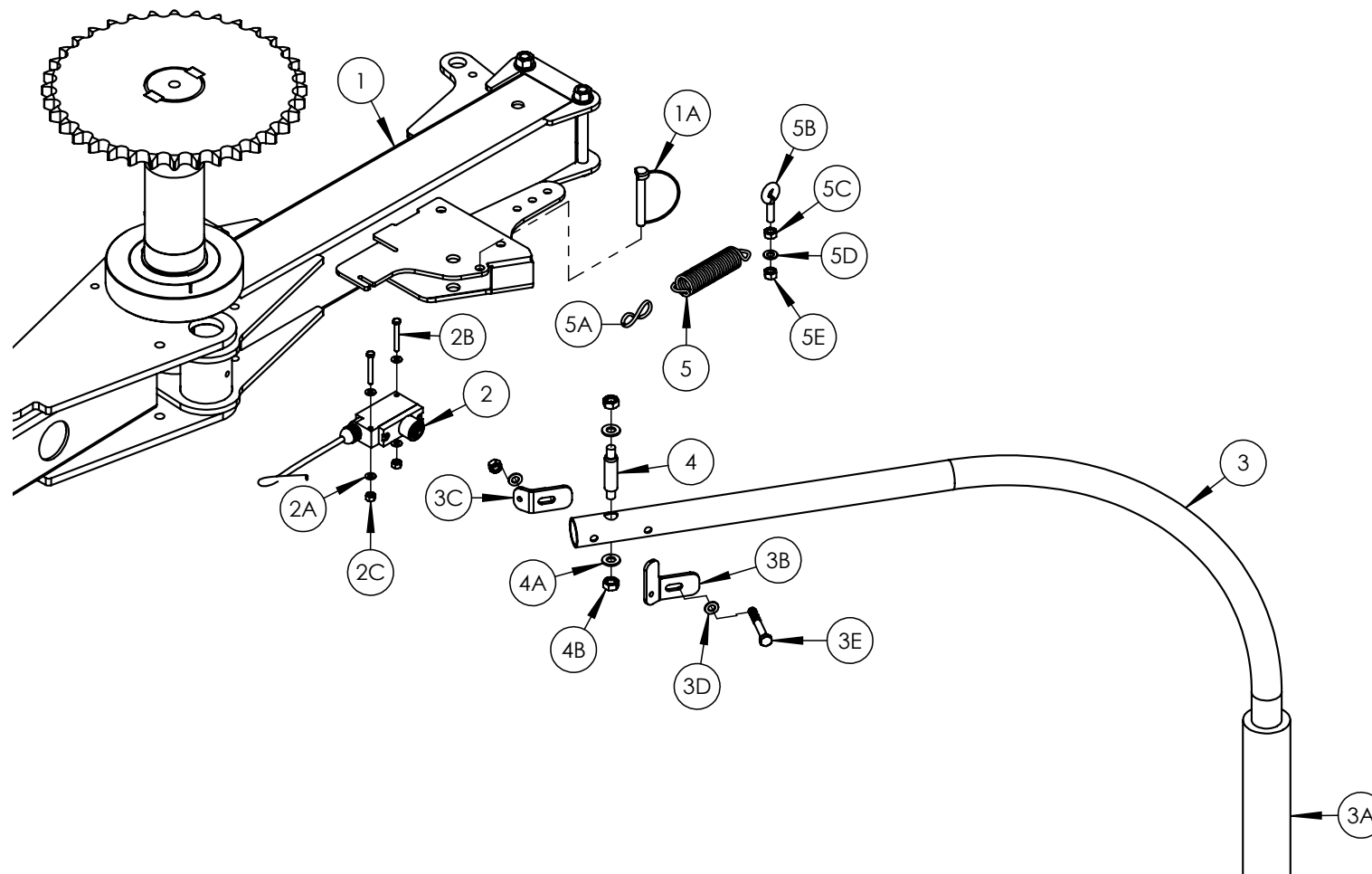

POS. NR. POS. NR. POS. NO.	TEILE NR. PART NR. PIECE NO.	STUCK QUANTITY QUANTITEE	BENENNUNG	DESCRIPTION	DESIGNATION	TECHNISCHE ANGABEN TECHNICAL DATA DONNEES TECHNIQUES
1	1114100	1		Main Rotating Arm		
1A	Z03-22-07	1		Curved Linch Pin		3/8"
2	34950179	1		Safety Switch		
2A	Z10-02-05	4		Flat Washer		M5
2B	Z26-0173S	2		Hex Set		M5 X 40mm
2C	Z23-05	2		Locknut		M5
3	1115010	1		Emergency Stop Arm		
3A	1115011	1		Emergency Stop Arm Cover		
3B	1404013	1		Switch Activator		
3C	34670152	1		Emergency Stop Arm Bracket		
3D	Z10-02-08	2		Flat Washer		M8
3E	Z26-047B	1		Hex Bolt		M8 x 60mm
3F	Z23-08	1		Locknut		M8
4	34105651	1		Pivot Bolt		M10
4A	Z10-02-10	2		Flat Washer		M10
4B	Z23-10	2		Locknut		M10
5	34430300	1		Spring		
5A	34660111	1		S Hook		
5B	34119043	1		Eye Bolt		M8 x 25mm
5C	Z18-08	1		Hex Nut		M8
5D	Z10-02-08	1		Flat Washer		M8
5E	Z23-08	1		Locknut		M8

Tanco Autowrap - 1120

Ersatzteilliste / Spare Parts Manual / Liste des pièces de rechange



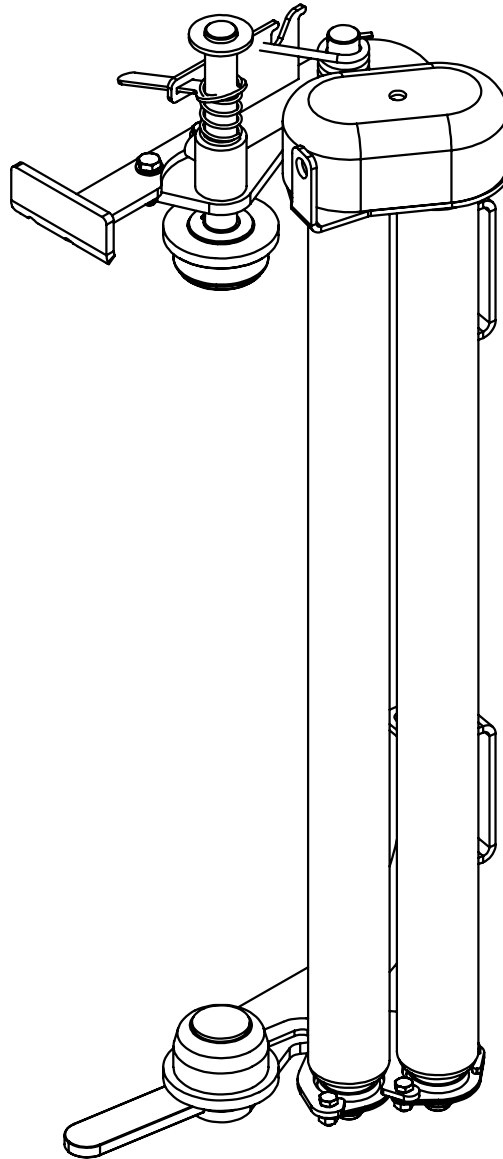

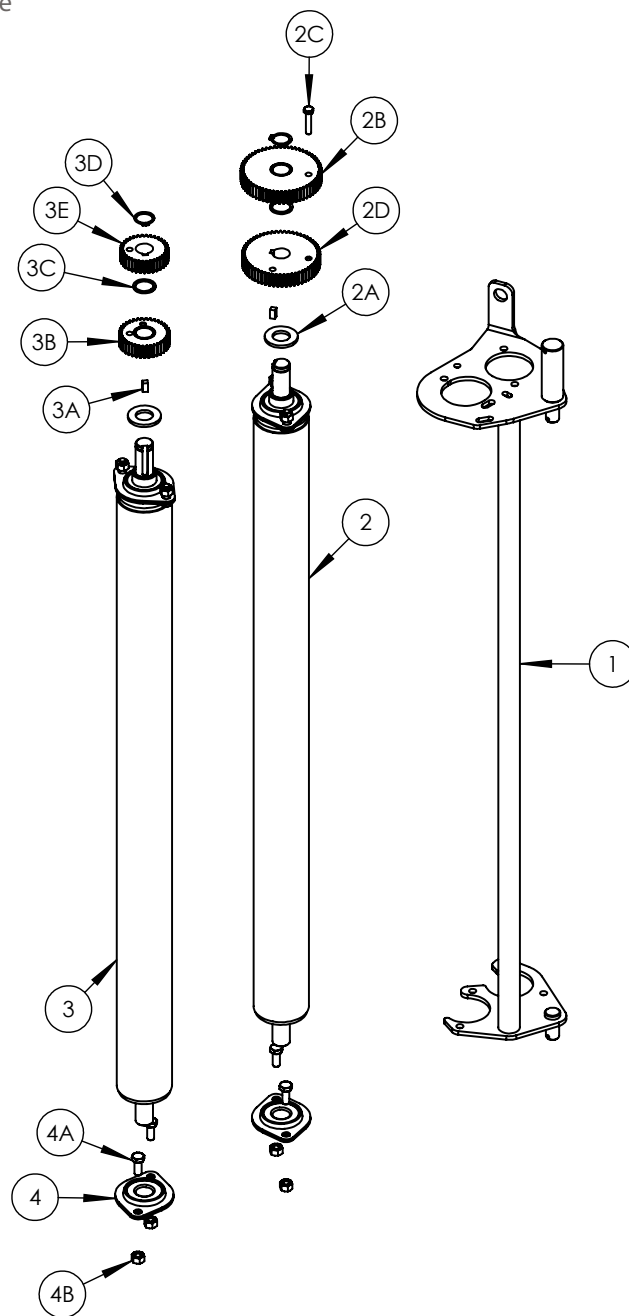

POS. NR. POS. NR. POS. NO.	TEILE NR. PART NR. PIECE NO.	STUCK QUANTITY QUANTITEE	BENENNUNG	DESCRIPTION	DESIGNATION	TECHNISCHE ANGABEN TECHNICAL DATA DONNEES TECHNIQUES
1	1115150	1		RA Roller Mounting Frame		
2	1305120	1		Inner Roller		
2A	Z10-02-20	2		Flat Washer		M20
2B	1305101	1		Gear		60T
2C	Z26-022B	1		Hex Bolt		M6 x 30mm
2D	1305103	1		Gear		58T
3	1305121	1		Outer Roller		
3A	1305123	2		Key Steel		6 x 6mm (12mm Long)
3B	1305104	1		Gear		37 T
3C	1305115	2		Copper Washer		M21
3D	Z28-520	2		Cir Clip		A20
3E	1305102	1		Gear		35T
4	1305122	4		Bearing		SLFL 20A
4A	Z26-039S	8		Hex Set		M8 x 20mm
4B	Z23-08	8		Locknut		M8

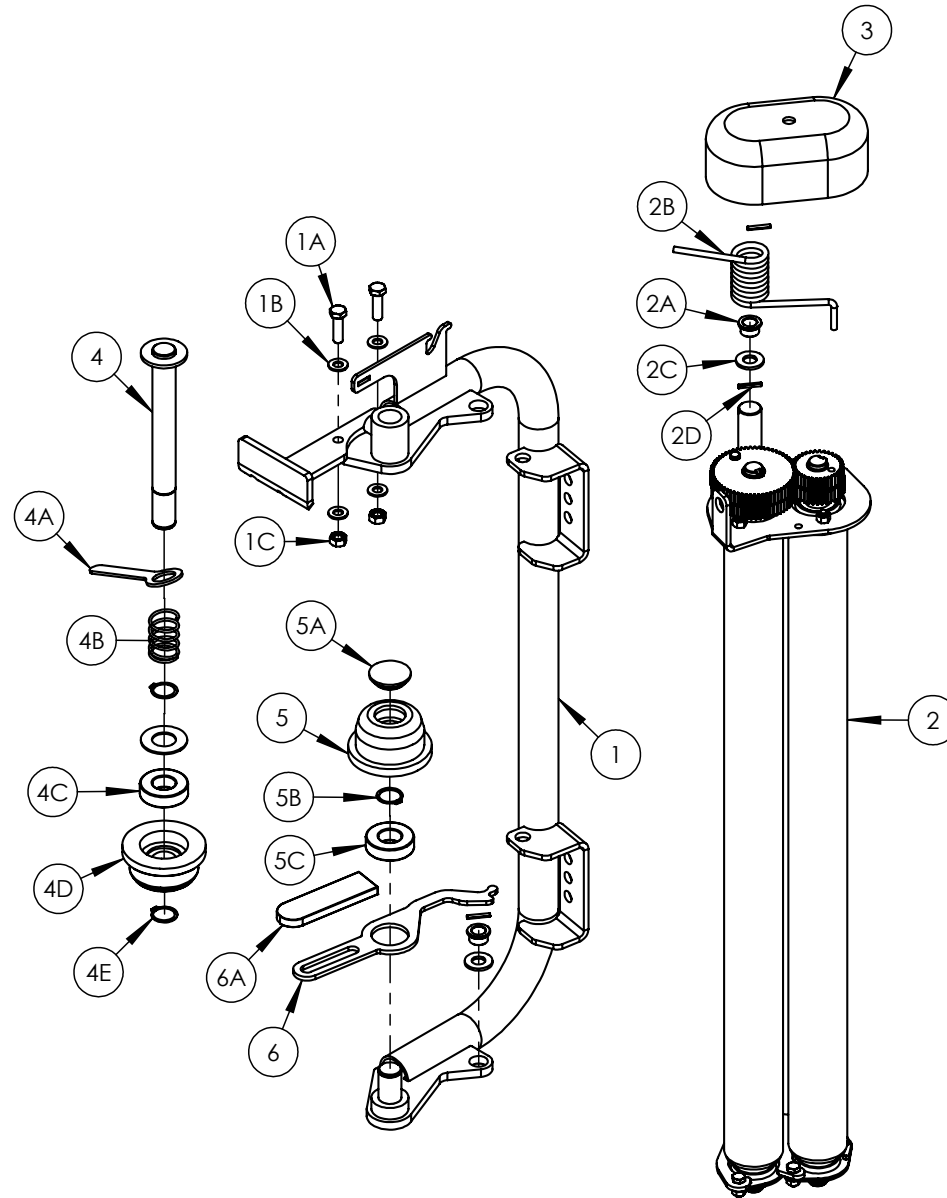

POS. NR. POS. NR. POS. NO.	TEILE NR. PART NR. PIECE NO.	STUCK QUANTITY QUANTITEE	BENENNUNG	DESCRIPTION	DESIGNATION	TECHNISCHE ANGABEN TECHNICAL DATA DONNEES TECHNIQUES
1	1115100	1		Standard Dispenser Frame		
1A	Z26-063S	2		Hex Bolt		M10 x 35mm
1B	Z10-02-10	4		Flat Washer		M10
1C	Z23-10	2		Lock Nut		M10
2	1115200	1		Insert Assembly		70/55%
2A	1115111	2				
2B	1115109	1		Torsion Spring		
2C	Z10-02-14	2		Flat Washer		14mm
2D	Z03-21-06			Roll Pin		M4 x 25mm
3	1305125	1		Gear Cover		
4	1115113	1		Top Shaft		
4A	1115117	1		Top Latch		
4B	1115116	1		Compression Spring		
4C	Z06-AWRB	1		Bearing		6205-ZZ LDK
4D	1115110	1		Nylon Cone		
4E	Z28-525	1		Circlip		Ext. M25
5	1405006	1		Bottom Nylon Cone		
5A	Z32-15F	1		Plastic Cap		1 1/4"
5B	Z28-525	1		Circlip		Ext. M25
5C	Z06-AWRB	1		Bearing		6205-ZZ LDK
6	1115107	1		Dispenser Bottom Latch		
6A	Z32-165	1		Plastic Latch Handle		

Tanco Autowrap - 1120

Ersatzteilliste / Spare Parts Manual / Liste des pièces de rechange



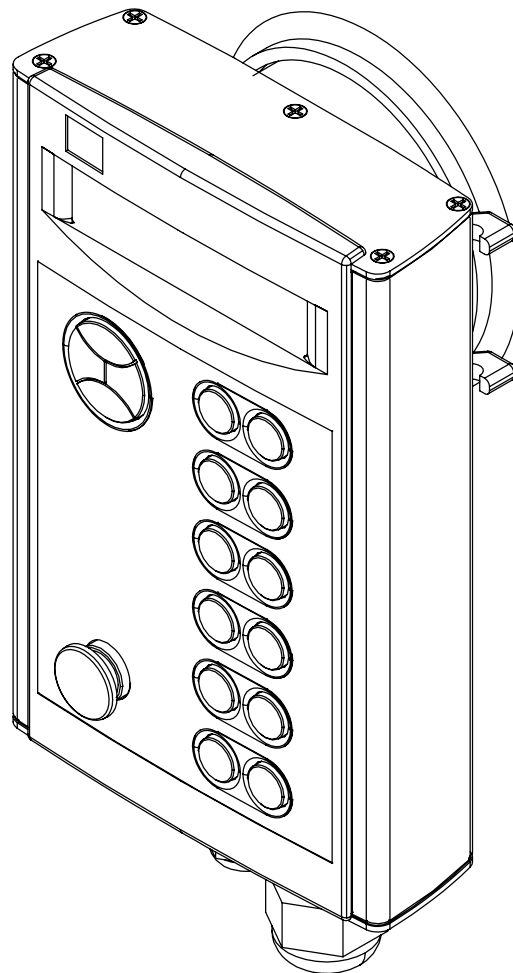

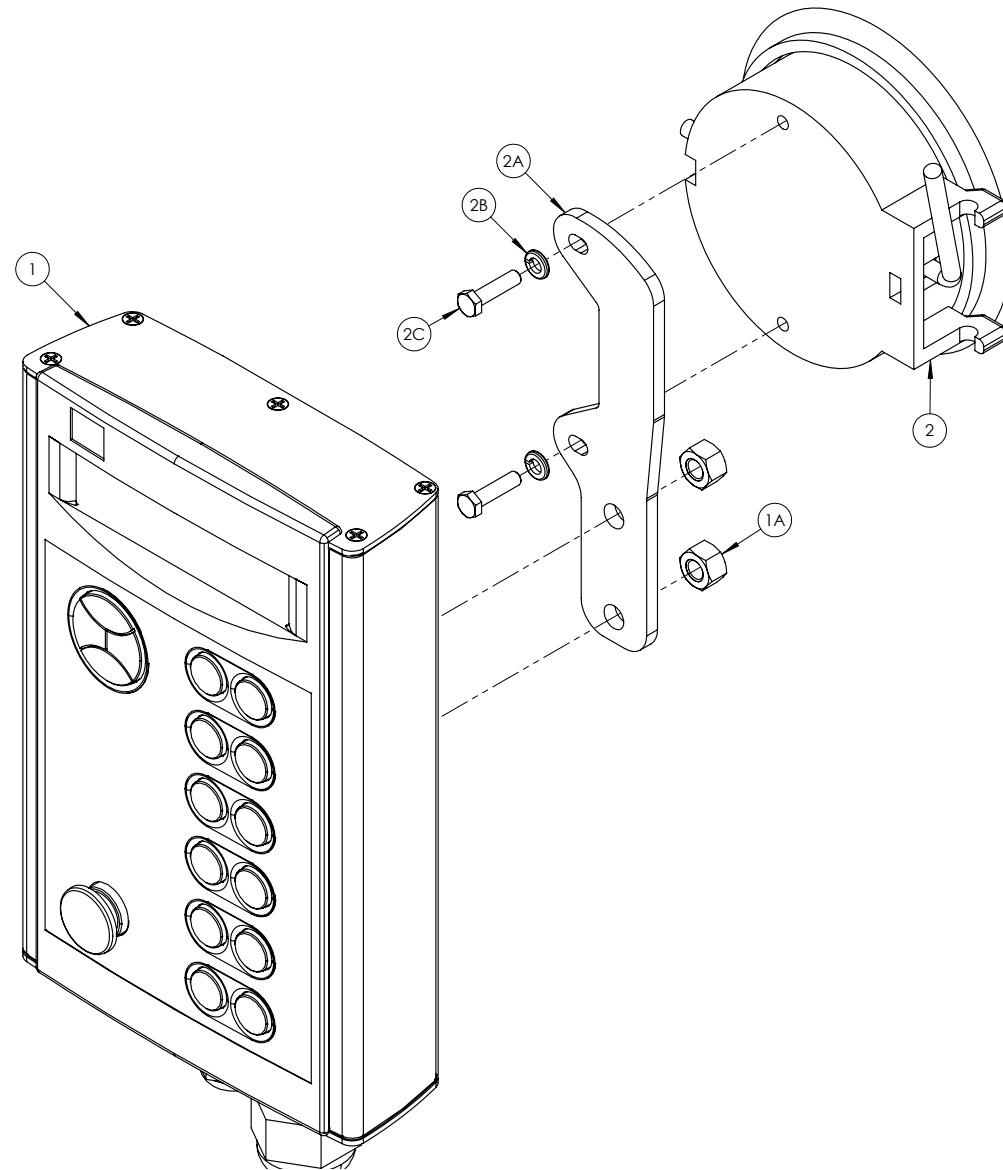

POS. NR.	TEILE NR.	STUCK	BENENNUNG	DESCRIPTION	DESIGNATION	TECHNISCHE ANGABEN
POS. NR.	PART NR.	QUANTITY				TECHNICAL DATA
POS. NO.	PIECE NO.	QUANTITEE				DONNEES TECHNIQUES
1	1309006*	1		RA Expert Control Unit		
1A	Z23-08	2		Locknut		M8
2	1309012	1		Suction Cup		
2A	1309011	1		Mounting Bracket		
2B	Z12-02-05	2		Spring Washer		M5
2C	Z26-017S	2		Hex Set	Vis de régl. Hex	M5 x 20mm