

1400 VARIWRAP OPERATOR MANUAL

V.01_EN

INNOVATION IN AGRICULTURAL MACHINERY

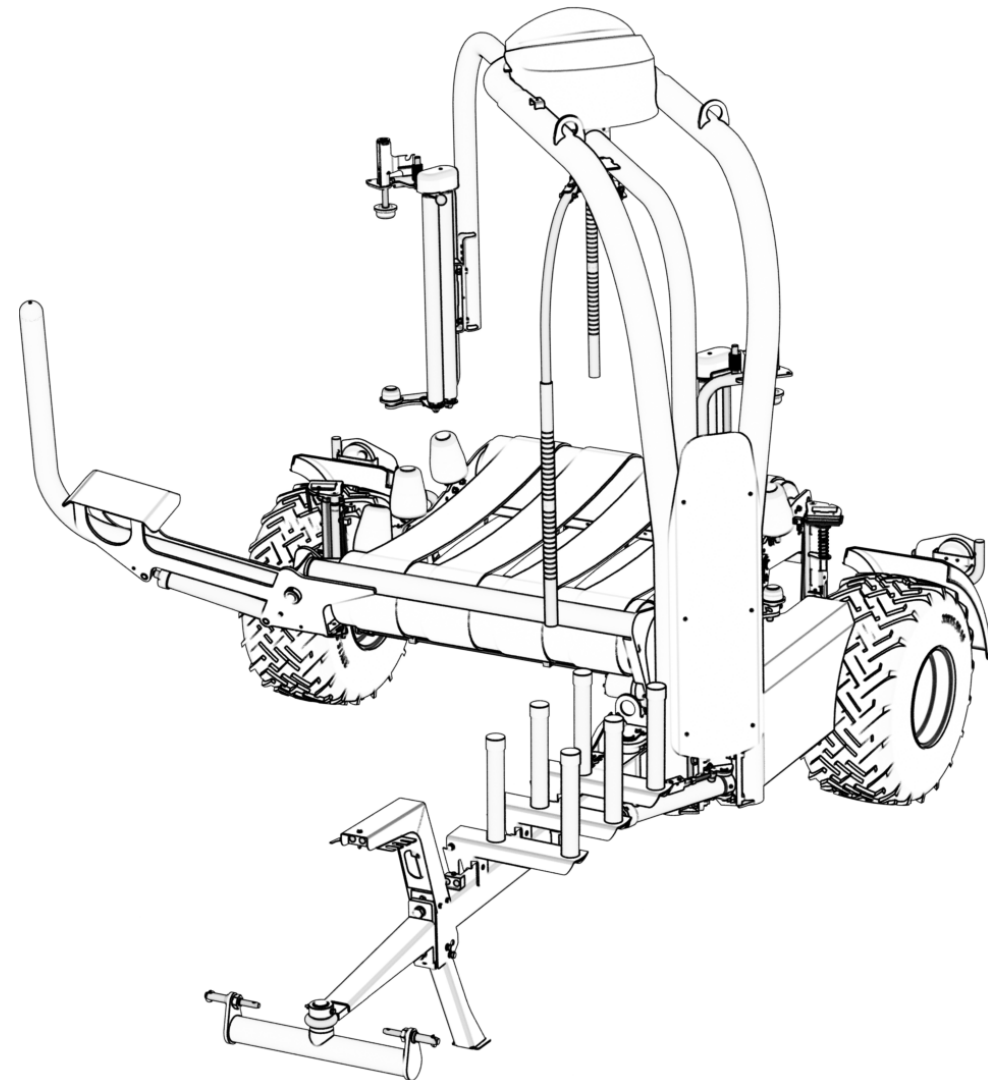

CONTACT

Address

Tanco Autowrap Ltd.
Royal Oak Road,
Bagenaltown
Co. Carlow
Ireland

Phone & Online

Phone: + 353 59 972 1336
Email: info@itanco.com
Website: www.itanco.com
Support: tanco.zendesk.com



INTRODUCTION

1400 VARIWRAP

Tanco Autowrap Ltd congratulates you on your choice of the TANCO AUTOWRAP 1400 bale wrapping machine. We are certain you will be satisfied with the machine, and that you will have the pleasure of your investment for many years. The TANCO AUTOWRAP 1400 is an efficient, high capacity bale wrapping machine. Its low centre of gravity and unique split table design ensures that power consumption is kept to a minimum without compromising output; this is a patented system. This machine is hydraulically driven by the tractor's hydraulic system and is controlled from the tractor cab by an automatic control unit. The machine is trailed directly behind the tractor for transport and offset to the right for working in the field. It loads the bale on the wrapping table in the same direction as it is discharged from the baler. The wrapped bale can be either dropped conventionally to the ground or with the fitting of an optional 'End Tip Ramp' the bale can be dropped on its end.

TANCO AUTOWRAP 1400 is designed to wrap bales of grass, hay or straw, with nominal diameter of 1.1 - 1.5m, and weights up to (1400kg). The machine was developed and has been improved since it's beginning in 2008, and is now a very reliable and safe machine with high security built in. This manual is meant to explain how TANCO AUTOWRAP 1400 is setup, attached to tractor, used and how it works, and shall together with the spare part's list be a reference for maintenance and troubleshooting. So take good care of this book; it is a part of the machine. Read carefully through this manual, and especially the safety instructions, before starting the machine. Follow the instructions thoroughly, if problems should occur, check the troubleshooting guide to try to establish the problem. Ask your dealer for advice before you attempt anything that may make the problem worse.

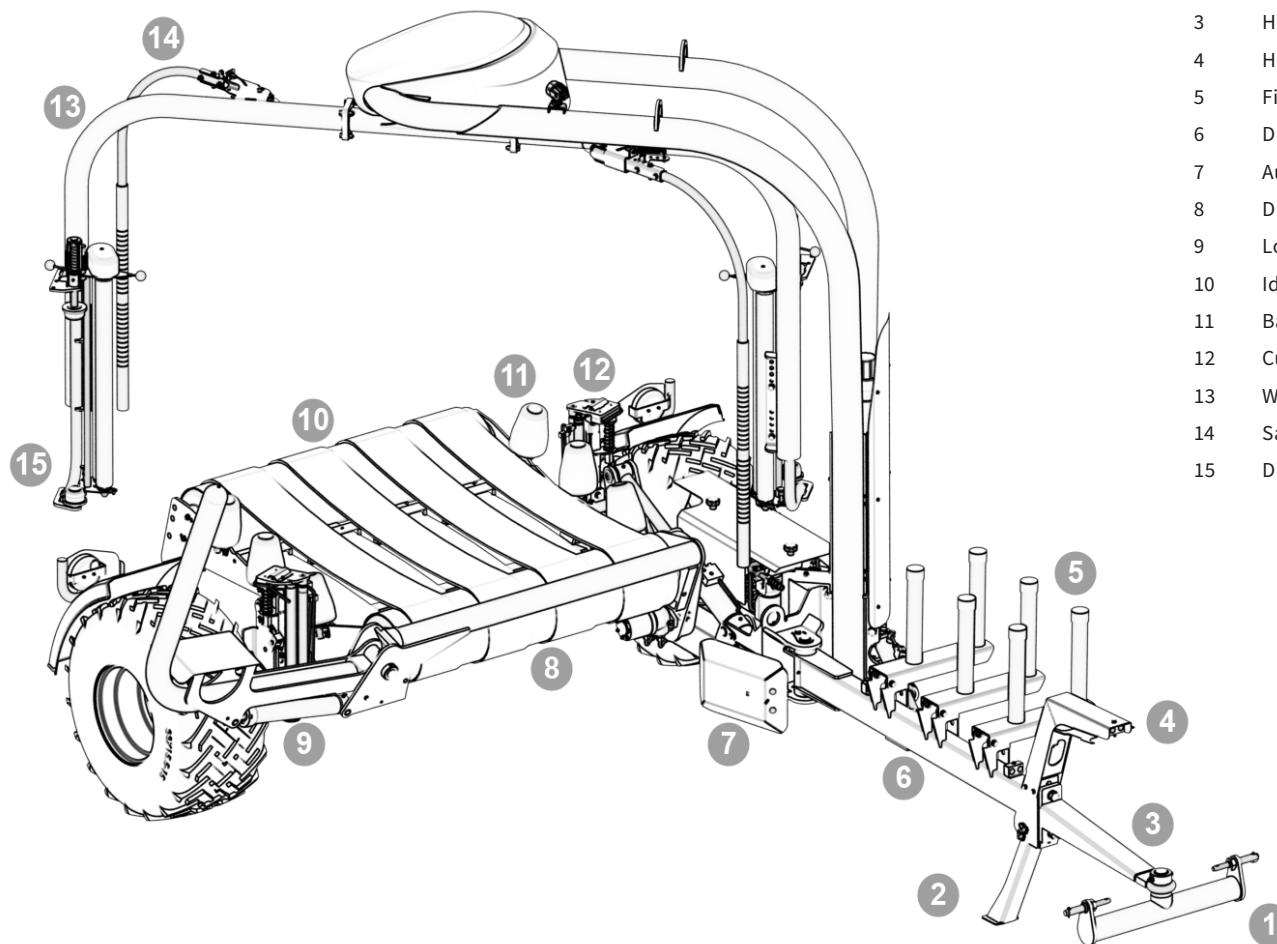

- 1 Lower Linkage Bracket
- 2 Drawbar Parking Leg
- 3 Hitch
- 4 Hose & Cable Guide
- 5 Film Roll Holder
- 6 Drawbar
- 7 Auto Load Actuator
- 8 Drive Roller
- 9 Load Arm
- 10 Idler Roller
- 11 Bale Guide Roller
- 12 Cut & Tie
- 13 Wrapping Arm
- 14 Safety Arm
- 15 Dispenser

ITANCO.COM

TABLE OF CONTENTS

SECTION 1		SAFETY DECALS
SECTION 2		TECHNICAL SPECIFICATIONS
SECTION 3		SAFETY PRECAUTIONS
SECTION 4		BALE WRAPPING
SECTION 5		MACHINE SETUP
SECTION 6		CONTROLLER INFORMATION
SECTION 7		OPERATIONAL INSTRUCTIONS & FEATURES
SECTION 8		ELECTRO-HYDRAULICS
SECTION 9		TROUBLESHOOTING & MAINTENANCE
SECTION 10		GUARANTEE / DECLARATION OF CONFORMITY

01 SAFETY DECALS

Areas which cannot be protected by devices are clearly marked by safety decals. It is important that all users of the this machine fully understand and follow these decal. If for any reason a decal

is missing or is damaged please contact you TANCO dealer for replacements.

Decal Locations
Safety Decals Explained

DECAL LOCATIONS

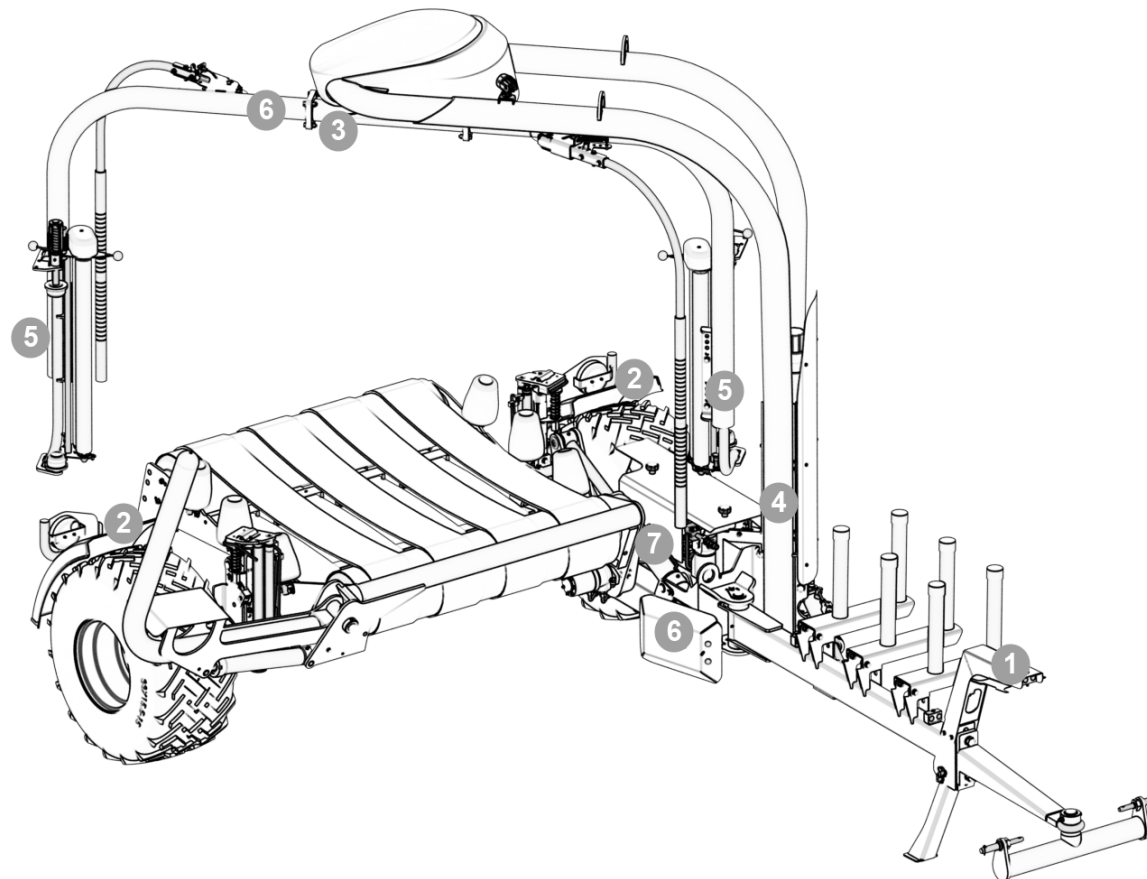

SAFETY DECALS EXPLAINED

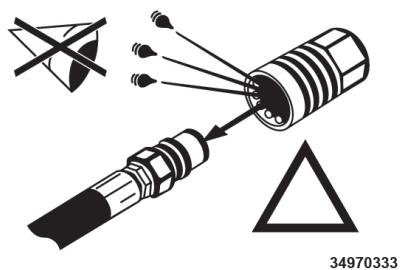

- 1 Warning, all hoses are constantly under pressure.

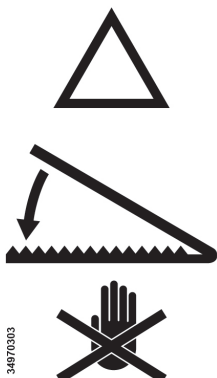

- 2 Danger keep hands clear of sharp blades.



- 3 Ensure wrapping arms do not exceed 30 RPM.

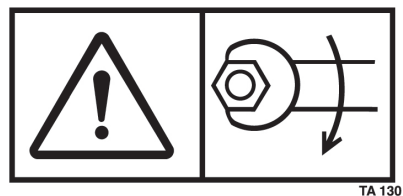

- 4 Ensure all nuts & bolts have been tightened prior to operating the machine.

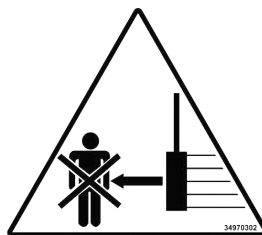

- 5 Danger from rotating Prestretcher



- 6 Danger stay at a safe distance whilst machine is in operation.

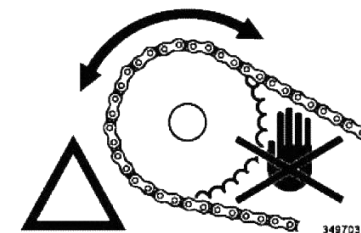

- 7 Do not open or remove Safety Guards while the machine is connected to the tractor.

02 TECHNICAL SPECIFICATIONS

Tanco Autowrap Ltd. reserves the right to modify the construction and/or technical specifications without warning and without rights to changes on already delivered products.

TECHNICAL SPECIFICATIONS

Height	2900mm
Width	2730mm
Length (min.)	3940mm
Weight	1,320kg
Wrapping Arm Speed (max)	30 R.P.M.
Maximum Bale Diameter	1500mm
Maximum Bale Weight	1400 kg
Pre-Stretchers	750mm (70%)
Hydraulic Connection	1pcs Single Working + Free Return
Oil Pressure	180 bar
Oil Amount (Max / Min)	60 lts/min / 30 lts/min
Maximum Counter Pressure	10 bar
Electrical Connection	12 V DC
Options	Load Sensing End Tip

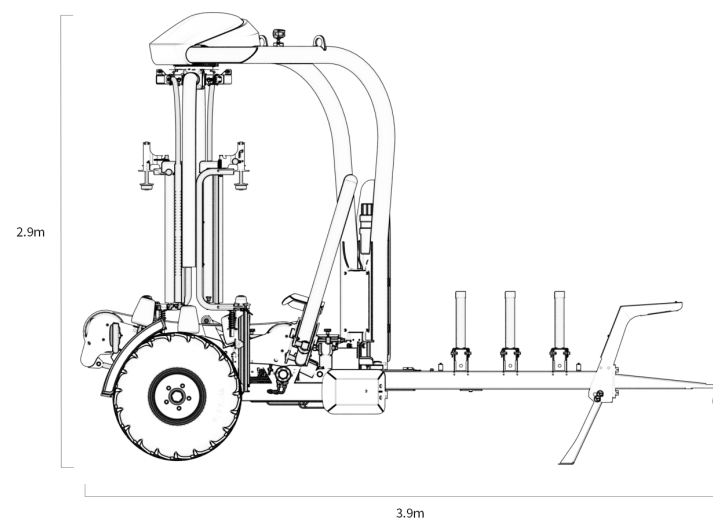
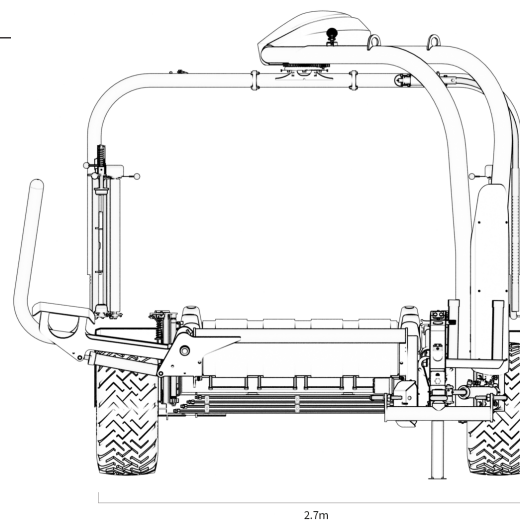

03 SAFETY PRECAUTIONS

Tanco Autowrap Ltd does not take responsibility for damages that may occur to machine, persons or other equipment, because of the machine NOT being used as described in this manual, or because of the safety precautions NOT being followed.

Emergency Stop
Safety Equipment
Become Familiar with the Operations of the Machine
Adjustments / Maintenance
Dangerous Areas
Impact of the Wrapping Arm
Squeeze Danger Between the Main Frame & Wrapping Arm
Squeeze Danger Between the Stationary Arm & Wrapping Arm
Impact of Bale Squeeze Arm
Impact Danger when Machine is being changed from Transport to Working Position at the Drawbar
Squeeze Danger Caused by Plastic Automation
Transporting
Autoload Function

SAFETY PRECAUTIONS

Emergency Stop

The Tanco Autowrap 1400 is equipped with a so-called emergency stop on the wrapping arm. This device stops all functions momentarily, but is per definition not an emergency stop, because it does not shut down the inputs. But it has the same function, so we have decided to call it an emergency stop in this manual.

Safety Equipment

Before using the machine, make sure that all guards and covers are securely fitted. The machine must not be operated if a function does not work as described later in this manual.

Become Familiar with the Operations of the Machine

If you are unsure how to operate the machine properly, either use of or maintenance to your Tanco Autowrap, please contact your Tanco Autowrap dealer.

Adjustments / Maintenance

Turn off the tractor and discharge the oil pressure before performing any adjustment or maintenance on the machine. Remember that a well maintained machine is a safe machine.

IMPORTANT!

Always make sure nobody is in the hazard area of the wrapping arm when the machine is in-use. The machine must not be operated by persons who do not know enough about how to safely operate the machine, or by persons under the age of 16 years. Dangerous Areas Tanco Autowrap Ltd. has given the safety to the operator the highest priority, but it is still impossible to secure oneself of every danger area on the machine. Therefore we have highlighted below some of the dangers that can occur when using the 1400 Tanco Autowrap Bale Wrapper.

Impact of the Wrapping Arm

During the wrapping process the arm rotates with a speed of 30-35 revolutions per minute around the bale. On the arm is mounted a Film dispenser unit with a plastic roll. Impact with this can cause serious injuries so the area in the path wrapping arm should not be entered during wrapping. If one enters the working area of the wrapping arm. To reduce this danger we have mounted an emergency stop device on the wrapping arm; this stops all movement when something comes in the way of it. It is very important that this protection always works and

that it should not under any circumstances be disconnected.

Squeeze Danger Between the Main Frame & Wrapping Arm

As explained earlier, we have a wrapping arm with a Dispenser and a plastic roll. During every revolution the wrapping arm passes the main frame. Here there may occur a squeeze danger if a person stands too close to the main frame when the wrapping arm passes. The distance between the main frame and the wrapping arm is not large enough to give place for a person. Between the pre-stretcher and the bottom frame there can also be a squeeze danger.

Squeeze Danger Between the Wrapping Arm and Main Frame and Chassis

The wrapping arms pass over the chassis and by the tower during each revolution of the wrapping process. The most dangerous area is where the wrapping arms approach the tower as the direction of rotation of the wrapping arm make it difficult to escape. There is a serious squeeze danger in this area. Keep out of this area when the machine is running.

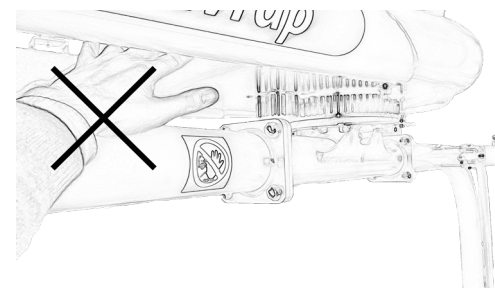

SAFETY PRECAUTIONS

Impact of Bale Squeeze Arm

During the bale loading process the bale squeeze arm moves both vertically and horizontally, beware of the danger and keep clear of this area whilst the machine is running. The pad that activated the Autoload function (automatically starting loading) is located on the chassis in the loading area. Ensure that the controller is powered off when working in this area as pressing on this pad can activate the Autoload function.

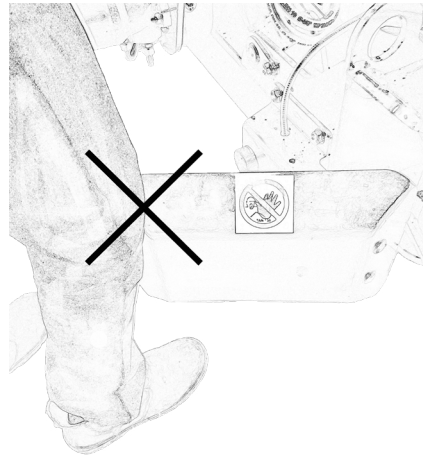

Impact Danger when Machine is being changed from Transport to Working Position at the Drawbar

When the machine is being changed from transport to the working position it rotates out to the right and when it is being put back into transport it rotates back to the left, beware of the danger and keep clear of this area whilst the machine is running; especially if the squeeze arm is in the open position.

Squeeze Danger Caused by Plastic Automation

At the end of the wrapping process the plastic is cut and held tight until the start of the next wrapping process. The 1400 has two telescopic cut and hold mechanisms. There is a danger of impact when these are opening and a squeeze danger when they are closing. There is a sharp blade near the lower gripper pad, keep hands away from this. The controller should be powered off when the film rolls are being changed, then the film end should be put into the slit in the cut and hold top plate to hold it for the first bale, the gripper need not be opened.

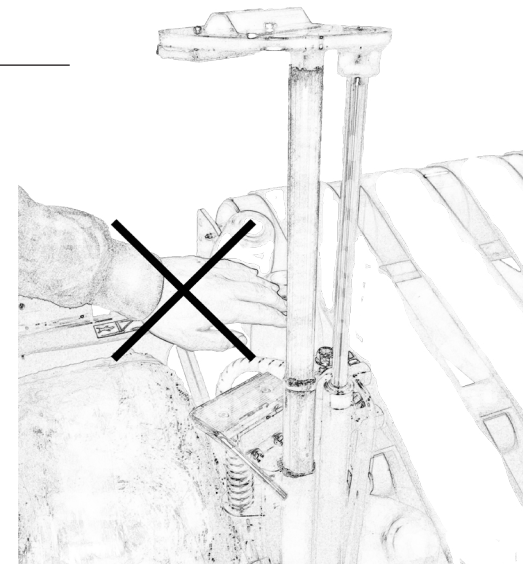

IMPORTANT!

Connecting heavy working implements often has an overall negative effect on the tractor's driving and braking capacity.

Transporting

When transporting on a public road there are certain safety measures that must be taken:

1. Ensure the machine is in the transport position.
2. Ensure the squeeze arm is fully closed.
3. Ensure that the wrapping arm is not parked overhanging the sides of the machine.
4. Ensure that the lights are connected and functioning correctly
5. It is recommended that the film rolls be taken off the dispensers for road transport and put on the film carriers on the drawbar. This reduces stress on the machine and reduces the danger of the rolls being accidentally falling off on the public road.
6. The machine is wide (2660mm) even in transport position, be aware of this especially on narrow roads.

04 BALE WRAPPING

BALE WRAPPING PRINCIPLES

The advantages of round bale silage are many, and include fewer feed units, a flexible harvesting system, large capacity and the possibility of selling feed units.

In principle, the same fermentation processes occur whether the fodder is placed in a silo or pressed into bales and packed in plastic, i.e. lactic acid fermentation in anaerobic conditions. The oxygen in the bale must be exhausted before fermentation begins. The grass should be dried to approximately 30-40% solid content. The solid content can be determined by twisting the grass by hand.

If drops of liquid are forced out of the grass, the solid content is less than 25%. Low solid content (wet grass) can lead to increased butyric acid fermentation if preservatives are not added to the grass. If the solid content is too high, (over 50%), normal fermentation will not take place and there will be enough oxygen in the bale to produce mould fungus.

The Baler
Difficult Bales
Types of Plastic
Storage Location
Stacking / Protection
For Best Wrapping Results.

BALE WRAPPING

The Baler

It is vital that the baler produces compact, well-formed bales, as misshapen bales can be difficult to wrap. Wrapping will also often take longer, thereby increasing the amount of plastic used.

Difficult Bales

Misshapen bale may not rotate correctly during wrapping and extra wraps may be required to fully cover the bale with the required number of layers of film. Observe the bale as it is being wrapped and if more wraps are required this can be done by pressing the +1 button on the controller.

If the bale to be wrapped is conical you must ensure that the sharp end is pointed at the tractor. It will then be easier to get the bale to lie correctly during packing. It is easy for such a bale to “turn” forward in the direction in which it is pointing, and therefore lie against the support rollers. If the bale is lying on a slope it must be picked up from the lower side. A hydraulic top link will again be advantageous.

Types of Plastic

A good type of plastic with good adhesive properties, and which is recommended for bale wrapping, must be used. The thickness of the plastic foil should be at least 25 μ . (25/1,000 mm). In order that the plastic tightens sufficiently around the bale, it is stretched before being wrapped, so it is somewhat thinner when it is put on the bale. With short-term storage (up to eight weeks) it is recommended that bales have a minimum of four layers of plastic at the thinnest points, with at least 52-53% overlap. For long-term storage, or when the grass is wet when it is wrapped, the bale should have 90-100 μ plastic (six layers) and the same amount of overlap. If thinner plastic is used, more layers should be applied. If it is very hot the plastic will be stretched further, and more layers should be applied. It is better to have slightly too much than too little plastic on the bale. From experience, light colored plastic produces slightly lower temperatures within the bale, and tends to improve feed quality.

Storage Location

Care should be taken in finding a suitable location for the storage of bales. The storage location should preferably be prepared before the bales are laid out. An elevation close to well-drained roads is recommended. If the wrapped bales are simply placed on stubble there

is a danger of the plastic being pierced. A tarpaulin or a thin layer of sand should therefore be laid where the bales are to be stored over the winter.

Bales should be stored in the shade as far as possible. This reduces the danger of air leakage in the bales. A bale which is stored in sunlight and which therefore undergoes greater swings in temperature “pumps in” a great deal of air in comparison to a bale stored in the shade. According to “Teknik for Lantbruket” [Technology for Agriculture] in Sweden, a bale stored in the shade has only 40% of the air leakage of a bale which is stored in sunlight.

Stacking / Protection

If bales are hard and well formed, they can be stacked vertically, but loose and misshapen bales with low solid content should not be stacked higher than one layer, as this could easily cause deformity and the danger of runoff will be increased.

Bales can also be stored on their sides. The layer of plastic is thicker here, providing greater protection against piercing.

Bales should be covered with a tarpaulin or a fine-mesh net to protect against birds and small rodents. If the plastic is pierced, it must be sealed with weatherproof, hard-wearing tape, preferably under the outermost layer of plastic. Ensure that the hole is adequately sealed.

For Best Wrapping Results...

1. Harvest the grass early.
2. Ensure the grass is dried out to 30-40% solid content. If there is a danger of rain, bale and wrap the grass anyway.
3. Take care not to mix any earth in with the grass.
4. Use a baler that produces even, firm bales. Bales 1.2mtrs in width and with a diameter of 1.2-1.5mtrs are preferred sizes.
5. Wrap the bales as soon after baling as possible; never more than two hours afterwards.
6. Use good plastic, it is recommended to apply six layers of plastic. This removes the need to use preservatives.
7. Store bales in the shade to reduce the danger of air leakage.

05 MACHINE SETUP

MOUNTING OF THE MACHINE

Be careful! There is a danger of being crushed when working implements are fitted and connected. Carry out the fitting procedures slowly and carefully, and use separate and approved

lifting equipment to make the work easier. Note the section on safety precautions and pay attention to the various safety decals displayed on different parts of the bale wrapper.

Attaching to the Tractor
Control Box
Hydraulic Connection
LS Hydraulics
Mounting of Plastic Film
Adjusting the Height of the Dispenser
Tanco Dual Stretch Dispenser

MACHINE SETUP

Attaching to the Tractor

The 1400 can be either connected to the tractor lower links using Linkage Attachment or by removing this it can be attached to the tractor hitch using the Hitch Eye. If the lower link bracket is used the Hitch Eye should be attached in the lowest position; this will allow greater movement.

If attached to the tractor hitch it is recommended that the machine is attached to the Clevis Hitch rather than the Pick-Up Hitch. This gives more clearance between the Drawbar and the tractor's back wheels. The Drawbar does not run directly behind the tractor. In transport the Drawbar runs nearer the left wheel so the minimum turning circle to the left is reduced. In the working position this is the case for turning to the right. When the machine is attached to the tractor the Drawbar Leg must be folded up to the Drawbar by removing the Drawbar Pin; swing the Drawbar Leg upwards and fit the Drawbar Leg Pin to Position B.

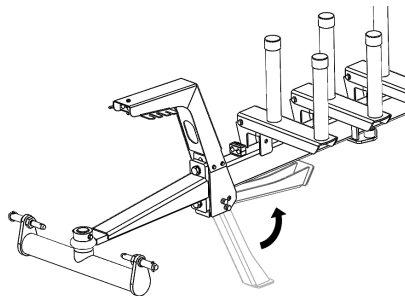

When attached to the tractor the machine should sit level, at this the squeeze arm will have 10cm approximate clearance with the ground when in the fully lowered position. Set linkage height to achieve this.

Adjust the linkage stabilizers to limit the lateral movement.

IMPORTANT!

If attached to the hitch change the hitch eye mounting position to set the correct height. Ensure the Hitch Eye Fixing Bolts are securely tightened.

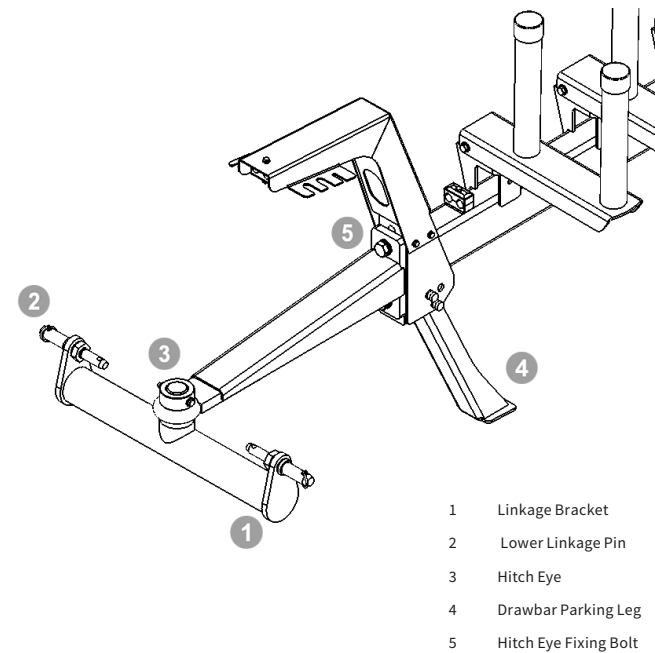

- 1 Linkage Bracket
- 2 Lower Linkage Pin
- 3 Hitch Eye
- 4 Drawbar Parking Leg
- 5 Hitch Eye Fixing Bolt

MACHINE SETUP

Control Unit

The 1400V control unit activates the automatic functions of the machine and also enables manual operation of these function. This unit should be mounted in the tractor cab within reach and where it can be conveniently viewed by the operator. A suction pad is supplied with the controller, this should be used for mounting (usually to the side window of the cab).

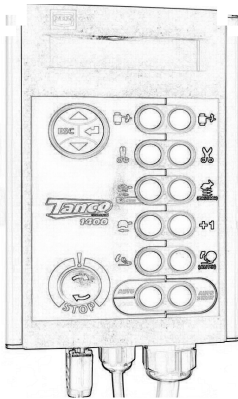

Electrical Connection

The controller system requires a 12v electrical supply with a current capability of 15Amps. There is a power cable to the junction box on the machine with a 3-pin euro plug which can be connected to the 3 pin Euro socket found in the cab of most modern tractors. If the tractor does not have a 3-pin euro socket then one should be fitted with the power cables going straight to the battery (Brown+, Blue-). The power cable from the controller is then connected to the socket on the junction box cable. The controller is protected from electrical overload with two 15amp fuses in an enclosure on the power cable. The controller is connected to the communication cable from the machine with a 37-pin connector. Take care when connecting this cable and ensure that the cables are not under strain and will not be damaged by sharp edges or the movement of the machine.

The controller is not waterproof so it should be protected from rain and stored indoors when not in use.

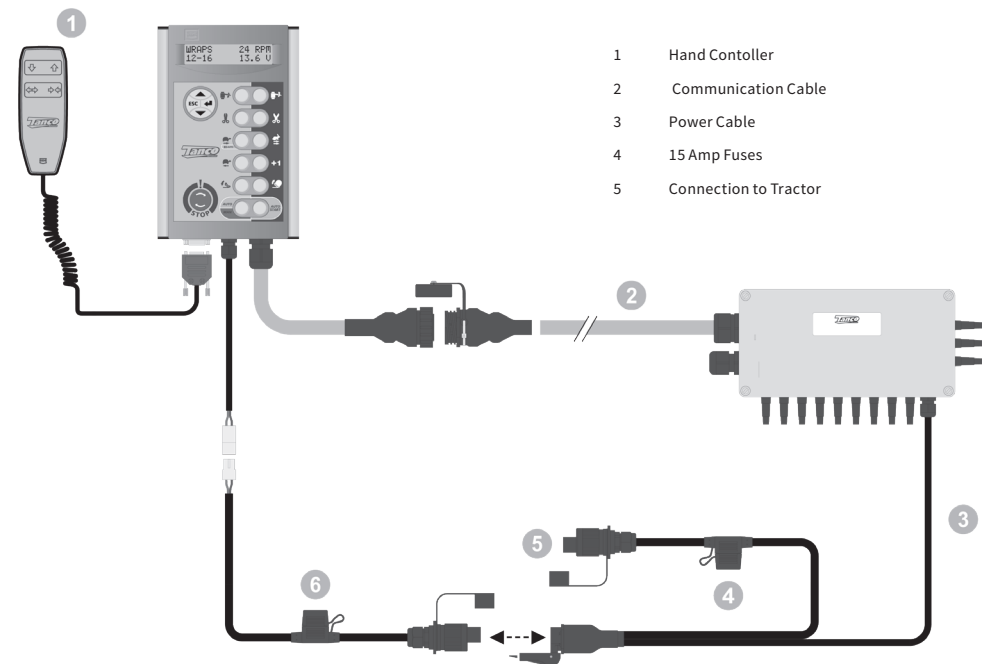

- 1 Hand Controller
- 2 Communication Cable
- 3 Power Cable
- 4 15 Amp Fuses
- 5 Connection to Tractor

MACHINE SETUP

Hydraulic Connection

The 1400V requires two hydraulic connections to the tractor, a pressure feed and a low-pressure return. The feed hose has a RED cap and the return has a Blue cap, both are fitted with ½" Male Quick Release Couplings. For operation on Load Sensing Hydraulic systems a third hose with a 3/8" coupling must be fitted. To get the 1400V to operate to its optimum the tractors' oil pressure must be at least 180 Bar and the oil flow rate should be 30 - 50 liters per minute. The return pressure should not exceed 10 Bar so it is recommended to use a free return point on the tractor. Consult your dealer if in any doubt with the tractors hydraulics.

Open, Closed Centre and LS Hydraulic Settings

The 1400 hydraulic system can be set up for tractors with Open, Closed Center and Load Sensing Hydraulics

Open Centre Hydraulics

Most tractors have a hydraulic system that gives a continuous output which flows through the valve on the machine and back to the tractor when no function is operating (Open center). The TANCO AUTOWRAP 1400V is set-up for open centre on leaving the factory.

Close Centre Hydraulics

Some tractors (John Deere) have a hydraulic system that require the valve on the machine to allow no flow when no function is operating (Closed Center). The 1400 hydraulic system is configured for Closed Centre hydraulics by setting the Closed Centre setting in the Technical Setup of the controller to ON.

Load Sensing Hydraulics

Many modern tractors have highly efficient Load Sensing hydraulics systems. With this the tractor only delivers the volume of oil required by the machine. To configure the 1400V valve for LS hydraulics an addition pipe is fitted to the LS ① port on the control valve. This pipe is connected to the LS signal port on the tractor so oils is sent to the machine when required.

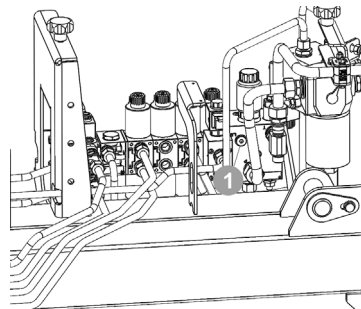

Also for LS V19 is fully closed. To change back to Open Centre, Open valve V19 ② and disconnect the LS signal pipe.

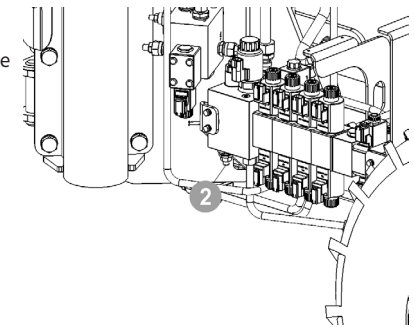

Check List

Before using the machine, it is recommended to follow this check list:

1. Always discharge the oil-pressure before connection or disconnection of the hydraulic hoses. (By operating the hydraulic control lever on the tractor).
2. Make sure to connect the hoses correctly: Red Cap= Pressure Feed, Blue Cap = Low Pressure Return.
3. Make sure the hoses and cables are routed correctly so they are not in danger damage with the movement of the tractor and machine.
4. Start the tractor and try out the functions. A bale is not required for this test. Take additional care if you are not familiar with the operation of the machine.
5. Check all connections, hoses and couplings. If there is any oil-leakage, it should be rectified immediately.

Your Tanco 1400V Bale Wrapper has been tested in practical operation in approximately 2 hours at the factory so if connected correctly it should run with little adjustment.

If any problems should occur, it is most likely that the failure is in the quick-couplers on the tractors pressure and return-connections.

Make sure that both the male and female-couplers opens properly for the oil flow, check these carefully. The best thing to do is to exchange the quick-coupling on the return side and arrange a "free return".

Your Tanco Autowrap Bale Wrapper has been tested in practical operation in approximately 2 hours at the factory.

MACHINE SETUP

Emergency Stop

This machine is equipped with safety guards on the Wrapping Arms, and its operation must be tested before work itself is started.

The Emergency Stop is to prevent the Wrapping Arm from damaging people and objects, when the machine is started and during the wrapping process. It consists of two safety arms that run in front of the film dispensers. When tripped they activate an electric switch, which gives a signal to the control box to activate the emergency stop. When testing this function, start the Wrapping Arm, hold out an arm or any obstacle. The wrapping arm shall now stop before it hits the arm. Great care must be taken when testing this function. To restart the machine the obstacle must be removed and the arm must be returned to its original position. The Auto Switch on the control box must be activated again. The wrapping may start again.

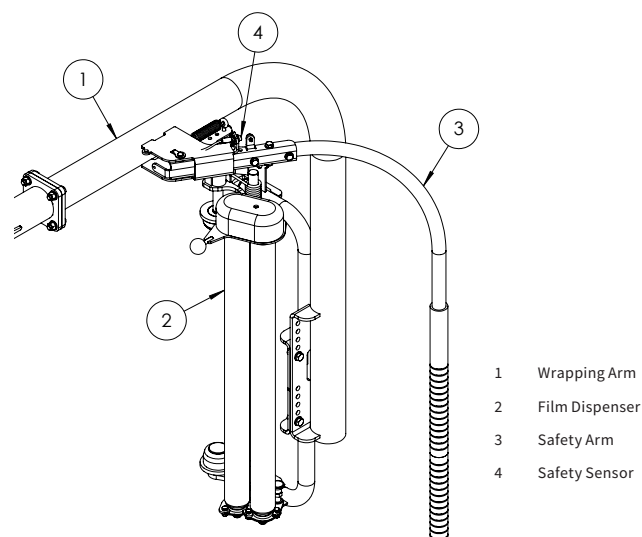

IMPORTANT!

GIVEN THE VELOCITY AND MOMENTUM OF THE ARM IT IS IMPOSSIBLE TO STOP THE WRAP ARM IMMEDIATELY. THE EMERGENCY STOP ARM IS PROVIDED TO HELP REDUCE THE RISK OF SERIOUS INJURY AND GREAT CARE MUST BE TAKEN WHEN OPERATING THIS MACHINE.

Adjusting the Height of the Dispenser

The standard film dispenser is designed for 750mm film. If using 500 mm film an adaptor is required which must be ordered separately. See parts book and contact your dealer. The plastic film should hit at the middle of the bale wrapped, and therefore it can be necessary to adjust the height of the pre-stretcher.

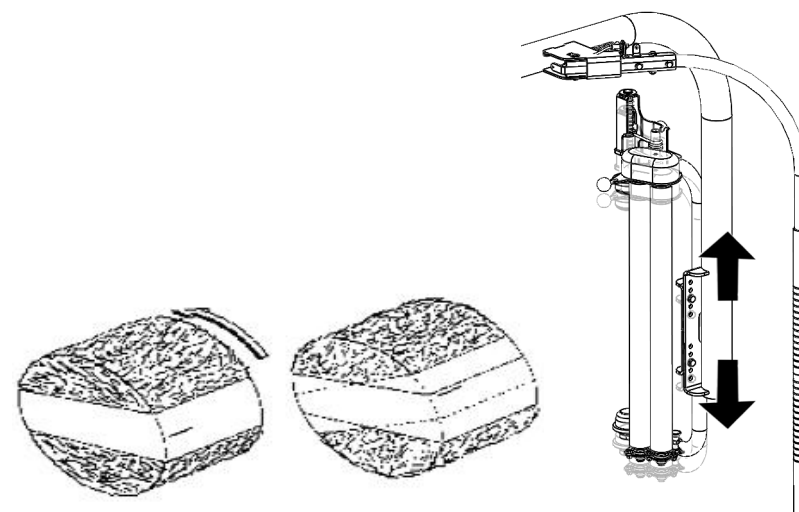

MACHINE SETUP

Mounting of Plastic Film

When loading a plastic roll, first ensure the Top Cone is pushed up to the latched position, then push back the Dispenser Insert until held in position by the Bottom Latch.

Place the Roll on the Bottom Cone and release the Top Latch.

BEWARE OF FINGERS!

Pull the film between the rollers on the Dispenser Insert in the direction of the arrow, as shown below. (See also the sticker on the dispenser).

Release the Bottom Latch and allow the rollers to lie against the roll of film. Pull the film from the roll and tie it to the bale.

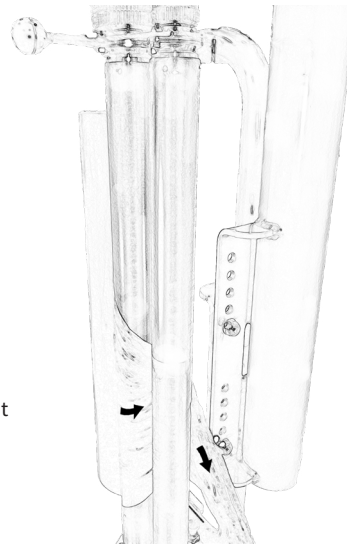

Tanco Dual Stretch Dispenser

All Tanco Autowrap machines are supplied with a patented dual stretch gear system. This system enables a quick change of stretch levels on the Film Dispenser.

If the Gear Bolt is fitted in Position 1, the top set of gears provide the stretch @ 70%.
By removing the Gear Bolt from Position 1 and fitting it in Position 2, the bottom set of gears become the stretch gears giving 32% (for prestretched film) or optionally 55% (for use in hotter climates or with square bales).

Tanco Dispenser Gear Combinations

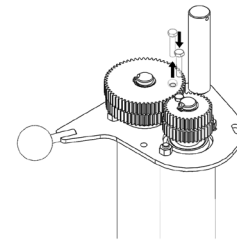

Inner Gear	Outer Gear	% Stretch
60 Tooth	35 Tooth	70%
58 Tooth	37 Tooth	55%
54 Tooth	41 Tooth	32%

- 1 Top Latch
- 2 Top Cone
- 3 Dispenser Insert
- 4 Bottom Cone
- 5 Insert Plunger

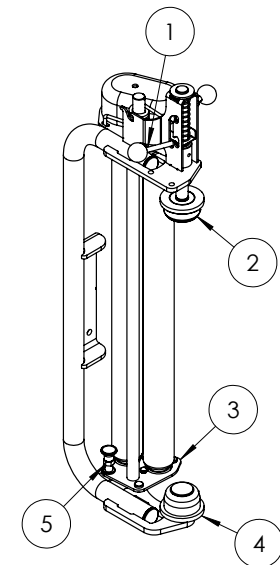

MACHINE SETUP

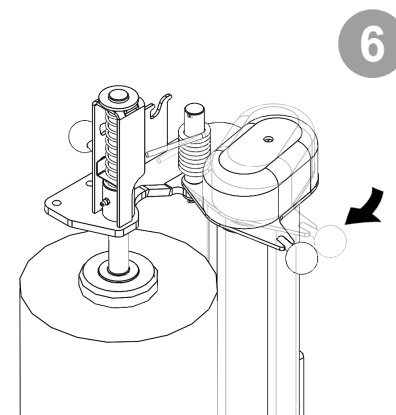
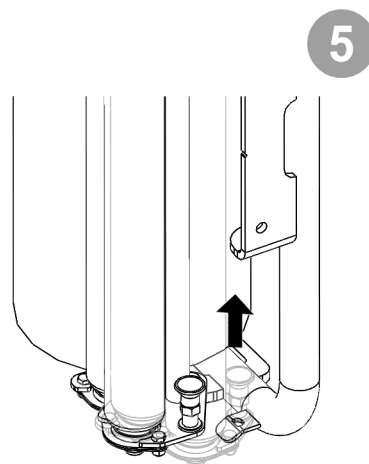
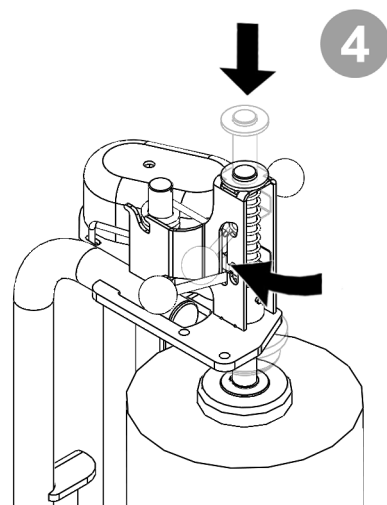
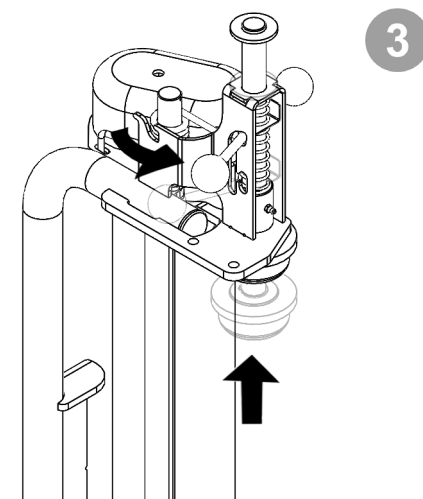
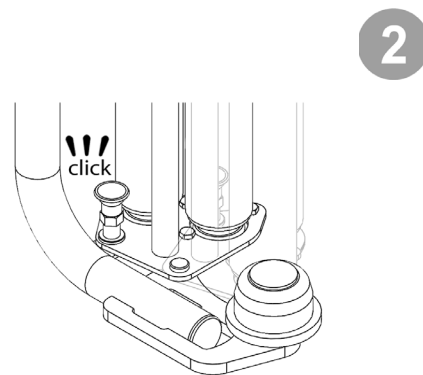
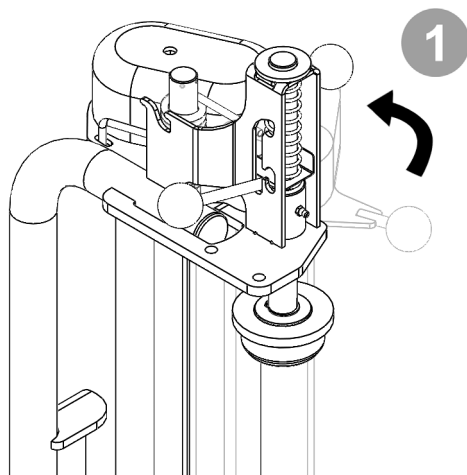

06 CONTROLLER INFORMATION

The Tanco 1400V Controller is designed to efficiently and safely monitor and control the operation of the bale wrapper. As part of quality assurance procedure all machines are run before dispatch from the factory. The controller parameters are set to suit the hydraulics and electrics of most tractors and the most common operating conditions. When machines are being set up for customers some settings may need to be altered to suit individual tractors and conditions. There are 2 operating modes – Automatic (A) and Manual (M). Changed with button L6. The Automatic Mode permits automatic operation of the machine, within this there are customisable levels from complete hands free to automated loading, wrapping and offloading with operator control between. Full automation reduces

- Controller Main Operating Functions
- The Display Menu
- Controller Warning Signals
- Changing Default Automatic Sequence
- Interrupting the Automatic Wrap Cycle
- Operation in Automatic Mode
- Handheld Controller
- Programmable Factors - Operator Level

the work load on the operator but the onus is still on him to monitor the operation of the machine and intervene if a problem or danger is observed. The Manual mode allows the various function of the machine to be manually controlled with the buttons on the controller. Bale counts are automatically logged in any one of 10 selectable memory stores, in addition to a grand total memory store

IMPORTANT SAFETY INFORMATION!

Please read and understand the instructions for using this controller before operating the machine. It is recommended that operators get familiar with the operation of the machine before operating in fully automatic mode. This controller is fitted with a push-button type On/Off Emergency Stop switch. Always ensure the controller is switched OFF via this switch before attempting any adjustment or maintenance to the machine. Please follow ALL other safety instructions given in the manufacturers' Operator's Manual for this machine.

CONTROLLER INFORMATION



- 1 Power On/Off / Emergency Stop
- L1 Move Drawbar to Transport Position
- L2 Cut & Grip Film
- L3 Slow Forward to Park Position / Controlled Stop during Wrapping
- L4 Reverse Wrap Arm
- L5 Bale Loading
- L6 Operating Mode: 'M' or 'A'
- R1 Move Drawbar to Working Position
- R2 Release Film Grip
- R3 Fast Wrap / Resume Wrap (After Manually Pausing)
- R4 Adds 1 Wrap to Current or Next Bale
- R5 Bale Off-load / In 'M' (mode): Tips Bale
- R6 Start Automatic Wrapping Cycle; press STOP switch to stop cycle

CONTROLLER INFORMATION

The Display Menu

The Display menu is divided into 3 sections. At the top level are the settings used during the daily work with the machine – i.e. Store totals, No. of Wraps, Debug information and Bale count down for service interval. The Operator Setup section enables the operator to perform adjustments to the machine operation – e.g. Auto settings, Controller configuration, time duration and time delay settings during the automatic cycle. The 'Technician Setup' menu is not normally accessible to the operator without a PIN access code. 'Technician Setup' is not covered by this manual. The 'Auto Park Sequence' allows for fast folding to transport position and fast unfolding to working position. Use the 4-way switch to navigate the menu. Each menu screen indicates which keys to press to make the settings. The instrument will default back to the main operating display after 30 seconds if no other key is pressed.

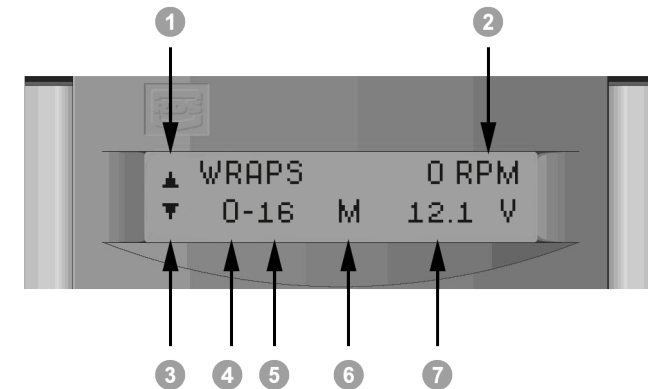

- 1 Scroll Up
- 2 Current Wrap Am Speed
- 3 Scroll Down
- 4 Current Wrap Count
- 5 Set no. of Wraps
- 6 Operation Mode; 'M' - Manual / 'A' - Automatic
- 7 Supply Voltage

CONTROLLER INFORMATION

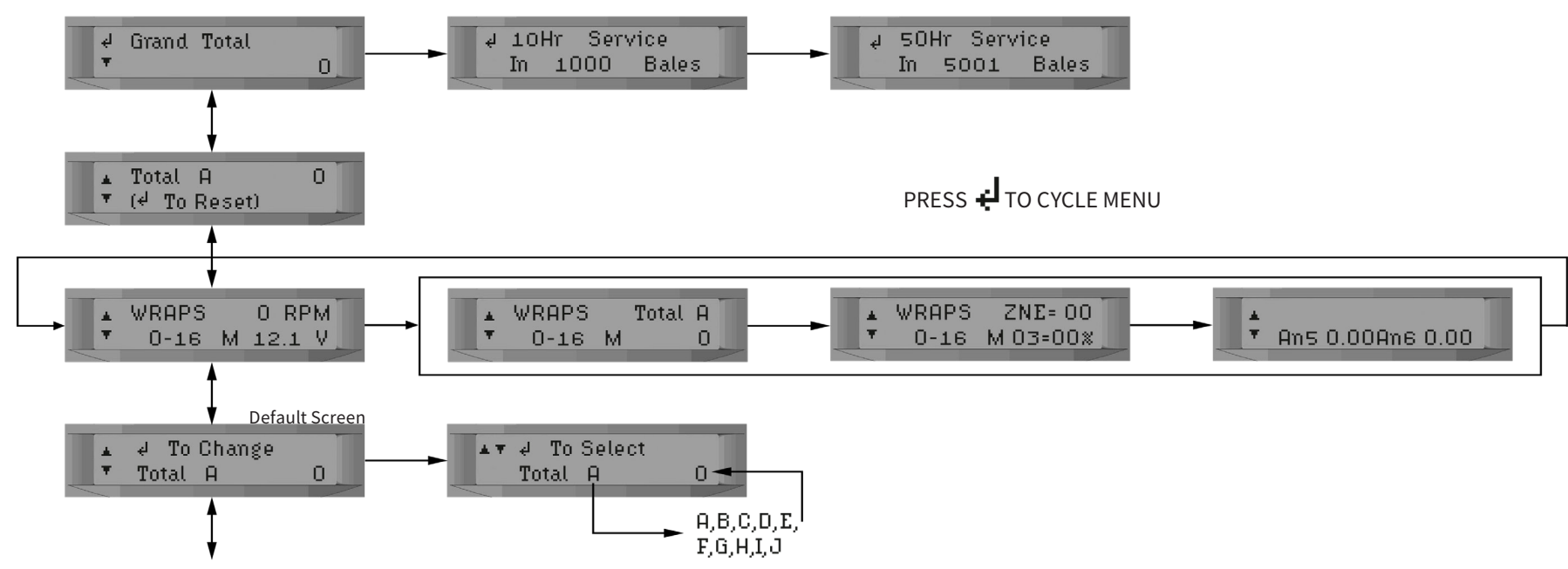

NOTE: ESC button will return to previous screen

CONTROLLER INFORMATION

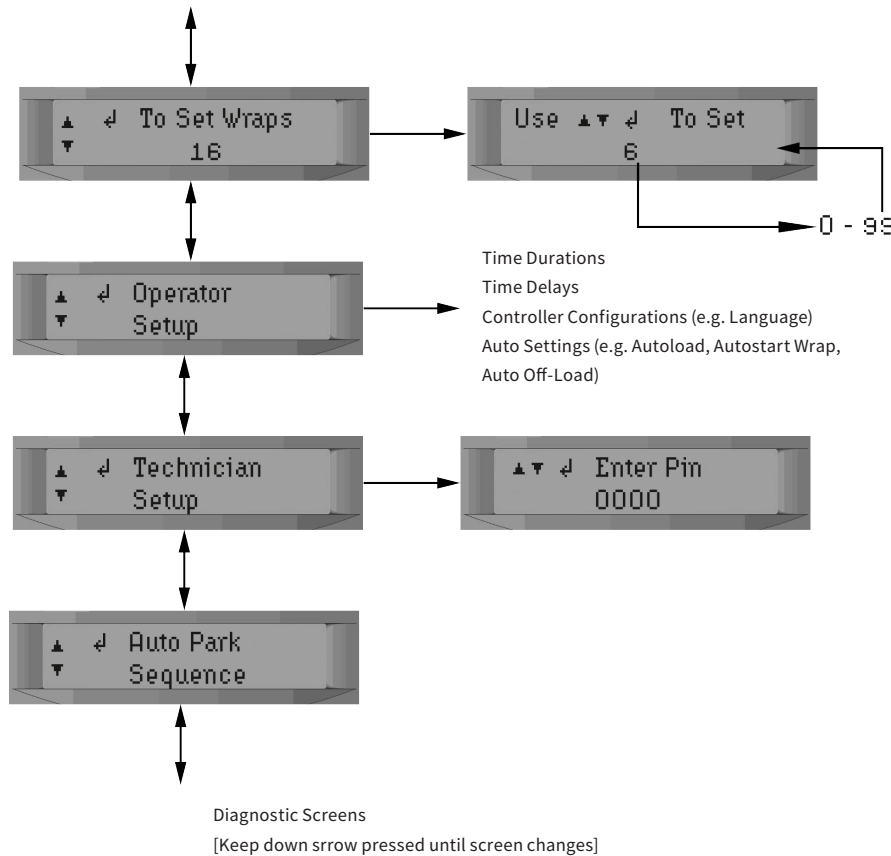

Selecting a Store Total

There are 10 individual memory registers labeled 'Store A' to 'Store J' for bale totals. Each time a bale cycle is completed, the currently selected store total and the grand total increments by 1.

The currently selected store is displayed on one of the two screens selectable in the normal operating mode. The default setting is Store A. To select a particular store, navigate the display menu using the 4-way switch. Press the Up/Down arrow keys to select the store, then press the ENTER key to confirm the selection.

Resetting a Store Total to Zero

Stores A to J can be individually reset to zero at any time. The Grand Total store cannot be reset. First select the store to be zeroed, and then navigate the display menu. Press the ENTER key to reset.





Setting the Number of Wraps

The default number of wraps is 16. You can set the target number from 0 to 99 by navigating the display menu as shown below. If you require 24 wraps navigate the menu and increment the Default value to 24.

NOTE: ESC button will return to previous screen

CONTROLLER INFORMATION

Contoller Warning Signals

WARNING SIGNAL	POSSIBLE CAUSE	POSSIBLE RESOLUTION
Reset Safety	Safety Arm at dispenser was triggered	Reset safety arm and press resume  (R3) when safe to do so.
Film Break	1)Dispenser rollers stopped rotating during wrapping sequence 2) sensors not aligned correctly with magnet	1) Replace film 2) Realign sensor correctly or switch 'Film Break' off.
One Dispenser	Only one dispenser is applying film	Pause Wrap sequence  (L3), Reset Film and resume  (R3)
Over Speed	Wrap arms exceed recommended rotation speed	Slow down oil flow or reduce 'Fast arm PWM'
Squeeze Out	Squeeze is not in fully open position	Set controller to 'M' and use out arrows on the remote to open squeeze
Load_UP Check	Front of Table is not in correct position for wrapping	Set controller to 'm' and raise table using up arrow on the remote
Dispenser Position	Wrap arms are not in park position under sensor	Move Wrap arms to park position using Slow Forward  (L3)
10 Hr Service	10 Hour service interval expired	Complete 10 Hour service requirements
50Hr Service	50 Hour service interval expired	Complete 50 Hour service requirements

Changing Default Automatic Sequence

The level of automation is set in the Operator setup on the controller, these are the parameters that can be altered:

- Autoload (Menu no. 4.50)

This enables (ON) or disables (OFF) the Autoload sensor. When set ON, the loading function will start when the autoload acuator is moved by the bale. When set to OFF the operator must press  L5 (or Up arrow on the hand controller) to start loading.

IMPORTANT SAFETY INFORMATION!

When Autoload is set ON controller must be powered down by pressing (Emergency  button) when changing film or if you are carrying out any work on the machine.

This is to avoid any accidental activation of the automatic loading sequence.

- Autostart Wrap (Menu no. 4.47)

When set ON wrapping will automatically start when loading has finished. When set OFF, the operator must push button  R6 (or Out arrows on the hands controller) to start wrapping.

- Auto Off Load (Menu no. 4.03)

When set ON offloading will automatically start when wrapping has finished. Great care must be taken when using Auto Offload as round bales can roll and cause danger when they are being offloaded. It is there advised that it is not used in hilly conditions. Also, to remind the operator that Auto offload is set ON, a reminder will appear the controller display when the controller is power up. The operator must push the enter button  to confirm that the function is still required ON.



- Auto Hand Cont. (Menu no. 4.40)

When set OFF, the hand controller manually operates the loading function, squeeze in/out, load up/down. When set On, the hand controller can be used to start the loading, wrapping and offloading functions.

Note: if the controller is switched to Manual (M) the hand controller will just perform the manual loading functions.

CONTROLLER INFORMATION

Manually Interrupting an Automatic Wrapping Cycle

Press  (L3) to bring the wrapper to a controlled stop. Pressing  (R3) will resume the auto-wrap cycle from where it stopped.

For safety reasons; if it is necessary to work on the machine (e.g. in the event of a film break or the film running out), the controller should be switched off with the red stop button and also disengage the hydraulic supply. Pressing the  (R3) button after switching the controller back on will resume the auto-wrap cycle from where it stopped. While wrapping the red stop button should only be used in an emergency situation to bring the machine to a stop as the sudden stop imposes unnecessary strain on the machine.

Manual Options in Automatic Mode

With the controller in Automatic Mode, the following manual functions are possible;



1. Slow Wrap (not while wrapping)

Pressing button  (L3) rotates the wrap forward at slow speed. The arm will stop when it comes to the park position, releasing and pressing again will move the arm to the next park position.

2. Reverse Wrap Arm (not while wrapping)

Pressing  (L4) rotates the wrap arm backwards. As with the slow wrap if this button is held down the arm will stop at the park position.

3. Fast Speed (not while wrapping)

Pressing button  (R3) rotates the wrap arms at fast speed. This should be avoided as the arms will come to a sudden stop when the button is released. Pressing button  (R3) will resume an interrupted wrapping cycle from where it was interrupted. When a cycle is interrupted the Automatic mode letter A on the display will be replaced with an R.

Interrupting the Automatic Wrap Cycle



In the event that the wrap cycle is required to complete before the wrap count is finished the controller offers the user the option to enter early wrap completion. By pressing the autostart Wrap button  (R6) the wrapper will enter slow speed and complete the wrap cycle early.

Operation in Automatic Mode

The controller displays A in the centre of the screen when in Automatic mode, M indicates manual mode. Pressing button  L6 toggles between both.

The automatic sequence is made up of three sections: Loading, Wrapping and Off-loading.

Each of these sections activate a number of automated function to perform the task.



Loading: (Started with  L5 button), Wrapping: (Started with  R6 button) and Offloading: (Started with  R5 button).

For safety the controller comes factory so when loading is complete the controller waits for the operator to activate wrapping and again to activate offloading after wrapping.

It is possible to set the controller to automatically start wrapping after loading and offloading after wrapping. see 'Changing Default Automatic Sequence'.

The 1400V is fitted with an Autoload sensor, it detects that a bale is in position for loading. The controller can be set to automatically start loading without the operator having to press any button.

Loading

Loading is started by pressing  (L5) or by pressing  on the remote control if Auto Hand Controller is set On (see Changing Automatic Default Sequence), alternatively loading can start automatically by the Auto Load sensor (see Changing Automatic Default Sequence).

Loading should start with the wrap arm in the park position, that is with the wrap arm indicator under the sensor, the load arm down and squeeze arm in the fully open position.

Note: If the wrapping arm is not in the Park Position then the controller will give an error message 'DISPENSER POSN' and it will not start loading. Correct the arm position using the slow forward L3 or slow reverse L4 buttons. The arm should automatically stop in the contact position using these buttons.

The loading sequence is as follows:

- The squeeze arm comes in. (Squeeze In time)
- The load arm raises. (to load up sensor)
- The squeeze arm opens fully. (to squeeze out sensor).

CONTROLLER INFORMATION

Wrapping



Wrapping is by pressing the autostart Wrap button **AUTO MAN** (R6) or by pressing  on hand controller if Auto Hand Controller is set On (see Changing Automatic Default Sequence).



Note: The squeeze arm must be in the fully out position for auto wrapping to start, if it is not the controller will give an error message 'SQUEEZE OUT' and not start wrapping. Correct the squeeze arm position and repeat.

The wrapping sequence is as follows:

- The wrap arm will start in slow speed and ramp up to full speed. (Slow start time)
- The Cut and Starts open twice to release the plastic. (C&S Open time)
- On the last turn the wrap arm ramps down to slow speed. (Delay to Slow)
- The Cut and Starts open.
- The wrap arm stops. (Delay to Stop)
- The Cut and Start closes. (C&S Close time 2)
- The wrap arm reverses to the park position.

Offloading

Offloading is started by pressing  (R5 button) or by pressing  on hand controller if Auto Hand Controller is set On (see Changing Automatic Default Sequence).

Note: The wrapping arm must be in the park position for offloading, if not controller will give an error message 'DISPENSER POSN'. Correct the arm position using the  (L3) or  (L4) buttons.

The offloading sequence is as follows:





- The offloading table lowers. (Tip down time)
- The front load table lowers. (Load down time)
- The offloading table raises. (Tip return time)
- The front load table raises to the standby position. (Arm adjust time)

Handheld Controller

In Auto (A) mode the hand controller can be set to manually perform loading functions (details

below) or auto starting function (with Auto Hand Cont. set On, see 'Changing Automatic Default Sequence').



-  In 'M' mode: Load Down
In 'A' mode: Starts Auto Off-load (Auto Hand Cont. : ON)
-  In 'M' mode: Load Up
In 'A' mode: Starts Auto Load (Auto Hand Cont. : ON)
-  In 'M' mode: Squeeze Out
In 'A' mode: Starts Auto Wrap (Auto Hand Cont. : ON)
-  In 'M' mode: Squeeze In

Adding additional Wrap

Each time you press  (R4) an additional wrap will be put on the current bale if the wrapping sequence is in progress, or onto the next bale if the automatic cycle has not yet been started. You can add as many wraps as required.

Operation in Manual Mode

'M' in the centre of the display indicates that the controller is set in manual mode. Pressing Auto/Manual button **AUTO MAN** (L6) will toggle between A and M.

Manual mode is intended just for setup and maintenance or to retrieve the odd difficult situation in the field. The machine cannot be efficiently run in this mode.

In Manual Mode the operator activates each function with the buttons on the controller. The software logic determines which manual functions can be activated at any time but not all safety locks are active in manual mode so the operator needs to observe what is happening as he activates each function and stop if there is a problem.

CONTROLLER INFORMATION

Programmable Factors - Operator Level

Menu No.	Operator Level	Default	Units	Notes
N/A	Target No. of Wraps	16		
4.01	Contrast	6		
4.02	Film Break	OFF		Switches On or Off - Film Break Sensor
4.41	Remote Type	IR		Optional Extra Remote Control
4.4	Auto Hand Cont.	Off		Always Set to Off
4.5	AutoLoad	Off		Switch On or Off Automatic Loading
4.47	Autostart Wrap	Off		Switches On or Off Automatic Wrapping Start.
4.03	Auto Off -Load	Off		Switches On or Off Automatic Off-loading.
4.07	Squeeze In	3.0	Seconds	Squeeze Arm in Time
4.08	Load Up	4.0	Seconds	Load Up Time
4.09	Squeeze Out	2.0		Squeeze Arm Out Time
4.45	Pause to Release	1.0	Seconds	Pause at when Load Up before Squeeze Release
4.46	Tip to Load Down	1.0	Seconds	Time from Tip to Front Down
4.23	Wraps to Release	*3	Pulses	No. of Wraps to First Film Release.
4.24	Release 2	*8	Pulses	No of Wraps to Second Film Release
4.25	Release Delay	0.0	Seconds	Delay from Passing Sensor to Cutter Opening
4.44	Del. to C&S Open	*0.2	Seconds	Time from Slow to Cutter Open
4.26	Delay To Slow	*0.3	Seconds	Time from Passing Sensor to Going Slow
4.27	Delay To Stop	0.2	Seconds	Time Past Sensor
4.49	Arm adjust	0.5	Seconds	Time Load Arm Raises for Ground Clearance
4.5	In line	Off		Switches On or Off In line Sensor Operation
4.35	Language	English		
4.00	Work Lights	Off		Switches work lights On or Off
5.01	Sequence	1400		
5.39	Slow Arm PWM	40	%PWM	Sets Wrapping Slow Speed
5.4	Fast Arm PWM	72	%PWM	Sets Wrapping Max. Speed

5.41	Rev Arm PWM	38	%PWM	Sets Reverse Speed
5.51	1-D Fast Speed	70	%PWM	Sets Speed with 1 Plastic
5.00	Service Warning	On	On/Off	Set the controller to alert the operator of service intervals
5.65	Load Up Check	On	Yes/No	Monitors the load UP sensor to ensure table up before wrapping
5.15	Slow Start Time	2	Seconds	Slow Time Duration at Start
5.16	C&S Open Time	0.3	Seconds	Cutter Opening Time
5.17	C&S Close time 1	0.3	Seconds	Cutter Closing Time During Wrapping
5.18	C&S Close time 2	2.0	Seconds	Cutter Closing Time at End of Wrapping
5.53	1-D Rolls Stop	1.0	Seconds	Table Rollers Intermittent Stop Time for 1 Film Wrapping
5.58	1-D Rolls Rot.	1.3	Seconds	Table Rollers Intermittent Rotation Time for 1 Film Wrapping
4.25	Release Delay	0.0	Seconds	Delay from Passing Sensor to Cutter Opening
4.44	Del. to C&S Open	*0.2	Seconds	Time from Slow to Cutter Open
4.26	Delay To Slow	*0.3	Seconds	Time from Passing Sensor to Going Slow
5.48	Tip Return Delay	*0	Seconds	Delay from Tip to Tip Return
5.5	Load Arm Down	3.0	Seconds	Load Arm Down Time
5.49	Tip Return Time	*2	Seconds	Tip Return Time
5.60	Hyd Type	Open Ckt		
5.61	Reverse +	0	Second	
5.64	Unfold Rotate	1	Second	
5.25	RPM Alarm	*35	Seconds	Maximum Wrapping Arm Speed
5.28	Set Default			Sets Controller Back to its' Default Settings

The default settings for the machine are developed by Tanco for optimal operation of the machine. However, the operator can change certain parameters in the 'Operator Setup' menu to take account of operational conditions.

07 OPERATIONAL INSTRUCTIONS & FEATURES

Transport & Working Positions

Auto Loading

Working Lights

Quick Setup Guide

End Tipping

OPERATIONAL INSTRUCTIONS & FEATURES

Transport & Working Positions

Working in the field the 1400V is off-set to the right hand side of the tractor, for road transport the draw bar is moved in so the machine runs directly behind the tractor. There are a number of functions to be performed to get the machine change from transport **1** to working position **2** (Unfold) and back (Fold). To make this task easier there is an automated sequence in the controller to perform the function in the correct order. To access this, press the down arrow on the 4 way menu switch a number of times until the display shows Auto Park, then press the enter button  on the 4 way switch. From here the move to transport or park position can be activated with the drawbar buttons. While the sequence is working, IN PROGRESS flashes on the display and the controller bleeps repeatedly.

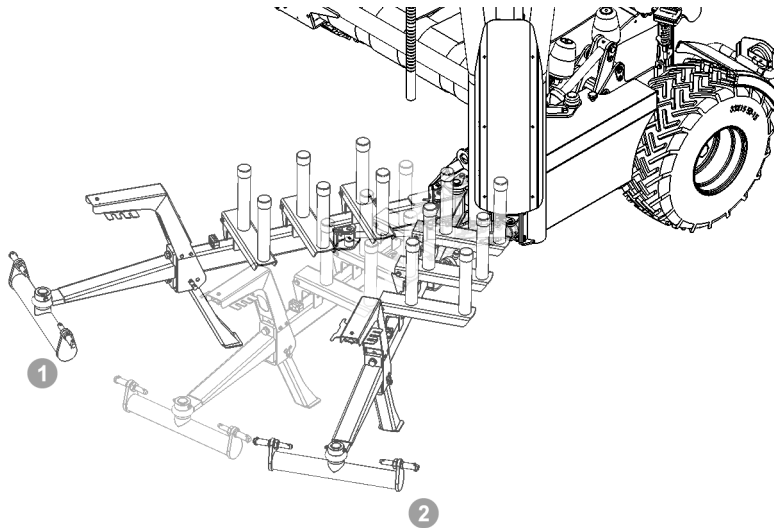

The Auto Unfold Sequence

Hold down the Drawbar Out button 

- The drawbar is opened (to sensor)
- The squeeze arm is opened (to sensor)
- The wrapping arm is reversed at slow speed to the park position
- The load arm is lowered (by the Load Down Time)
- The load arm is raised (by the Arm Adjust Time)

The Auto Fold Sequence

Hold down the Drawbar In button 

- The load arm is raised (to the sensor)
- The wrap arm is rotated forward at slow speed (by Unfold Rotate time)
- The squeeze arm is close (by Squeeze In time)
- The drawbar is closed (to sensor)

It is recommended for safety that the rolls of film be removed from the dispensers and placed on the film roll holders during transport.

Auto Loading

The 1400V is fitted with an Autoload sensor **1** it detects that a bale is in position for loading. The controller can be set to automatically start loading with the operator having to press any button. When the Autoload actuator **2** comes in contact with the bale it will start the loading sequence.

Ensure that the controller is powered off when working in this area as pressing on this pad can activate the Autoload function.

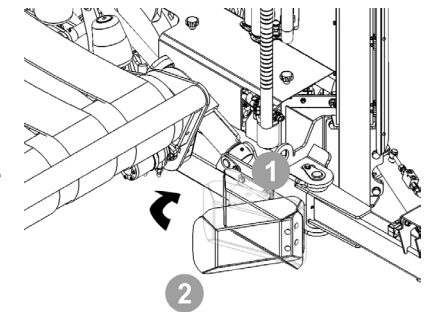

OPERATIONAL INSTRUCTIONS & FEATURES

Working Lights

The 1400V is fitted with working lights as standard. These can be switched in the Operator Setup on the controller:

1. Go to the Operator setup, enter and up arrow once (on 4-way switch).
2. Working Lights: ON/OFF

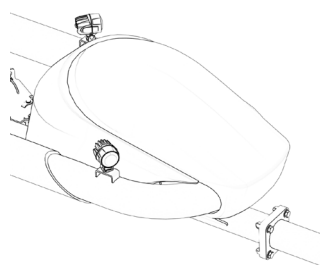

Quick Setup Guide

Before setting the 1400V to work ensure that;

- It is correctly attached to the tractor with lower link height set to have the machine level
- The hydraulic hoses are connected correctly, feed and free return (and LS pipe if fitted)
- The electric supply to the machine and controller are connected
- The film rolls are mounted on the wrap arms with the film threaded correctly through the dispenser and ends in the cut and starts
- The controller is set for the required number film layers
- The controller is set for the correct level of automation to safely work with the bales and ground conditions presented

The controller allows for varying degrees of automation and operator intervention in the control of the 1400V machine. This is described in detail in the controller section of this manual. This should be read before proceeding to operate the machine. Operating with full automation reduce the work load on the operator but it onus is still on him to closely observe the operation of the machine and to intervene if there is a problem. When operating in less than ideal conditions for example when wrapping badly shaped bales or if wrapping in hilly areas it is advisable to break the sequence into the three sections;

1. Loading
2. Wrapping
3. Offloading

Loading

Set the machine into the loading position

Drive up to bale, keeping the Autoload actuator plate **3** close to the end of the bale. Loading will automatically start (if the Autoload set ON) when the autoload actuator pushed by the bale. If Autoload is set Off, the operator must activate loading by pushing  button L5 when the load frame cross tube **2** is in contact with the bale. Provided the wrapping arms are positioned beneath the wrap arm **4** arm rotation sensor **5** the loading arm **1** will engage the bale and the machine will run the complete loading sequence.

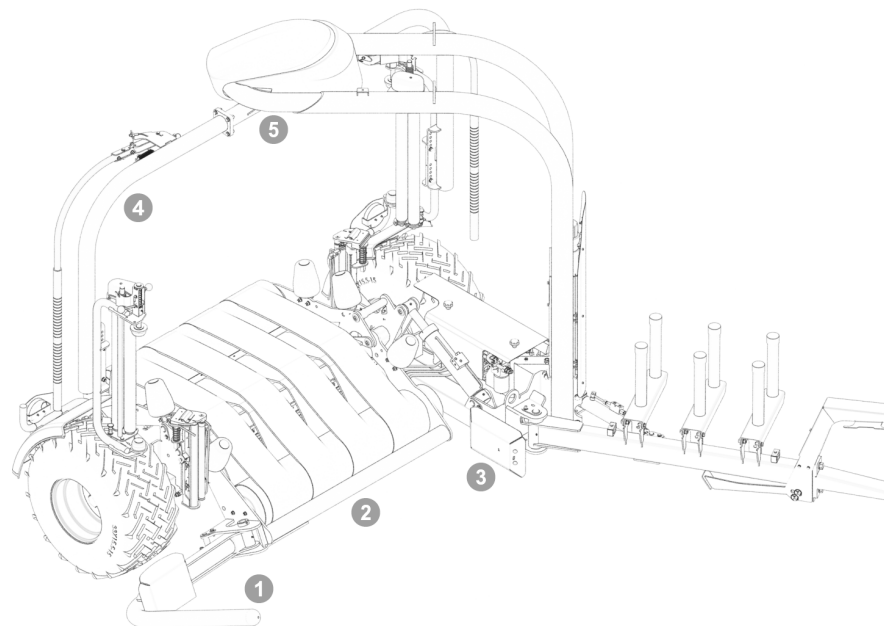

OPERATIONAL INSTRUCTIONS & FEATURES

Wrapping

Ensure that the bale has loaded correctly on the table before starting wrapping. The machine will automatically start wrapping if Autostart wrap is set On. If Autostart Wrap is set Off, then the operator must press button **AUTO START** R6 to start wrapping. Note: The Squeeze Arm must be in the full out position for wrapping to commence. The machine runs the complete wrap sequence after which the bale is ready for Offloading.

Offloading

If Auto Off-Load is set to ON, then the bale will be automatically off-loaded at the end of wrapping. If Auto Off-Load is set to OFF, the operator must press button **R5** to start off-loading. The machine runs the complete Offloading sequence.

Beware of the danger of the bales rolling when working in hilly conditions, always off load the bale across the hill.

End Tipping (Optional)

The 1400V can be fitted with an optional bale End Tipping attachment. The bale rolls onto this and is turned on to its end as it is being off-loaded. The End tipping attachment must be removed to change back to conventional offloading. This is easily done by removing the two attachment pins.

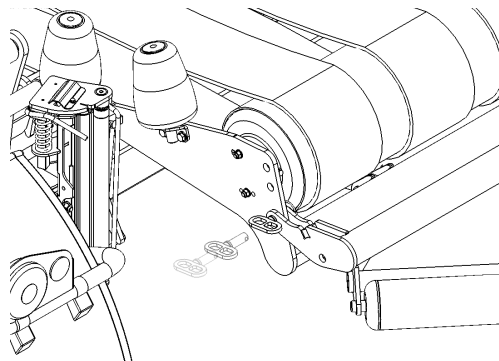

To avoid damage to the bale the 1400 should be stationary when End Tipping. The operation of the end tip attachment is heavily dependent upon the terrain and the bale shape. The mounting height of the wheel **1** is adjustable to improve operation with different bale sizes and operating conditions. The angle of the cone rollers **2** can be adjusted to suit different size bales.

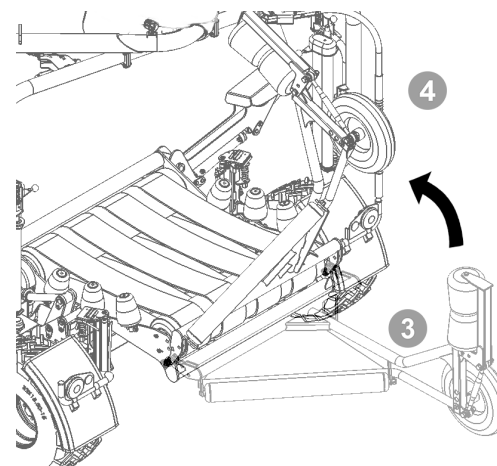
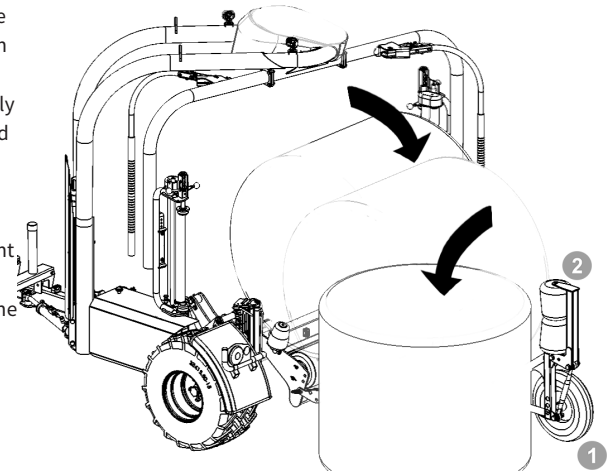

When travelling on roads the End Tip must be moved from the working position **3** and moved to the transport position **4**.

08 ELECTRO- HYDRAULICS

Basic Principles

Hydraulic Diagram

Description of Hydraulics

Valve Electrical Connections

Wrap Arm Electrical Connections

Junction Box Label

ELECTRO- HYDRAULICS

Electro-Hydraulics

There are 3 basics, which must ALWAYS be followed if the machine is to function correctly.

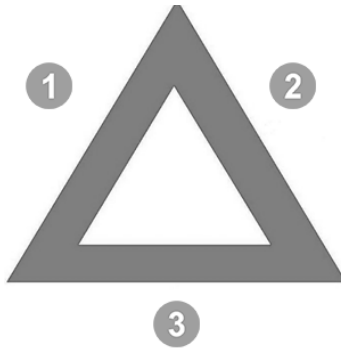

- 1 Working Pressure; 185 bar
- 2 Free Return; Max 10 bar (Direct to Tank)
- 3 Voltage; 12 V (Straight from Battery)

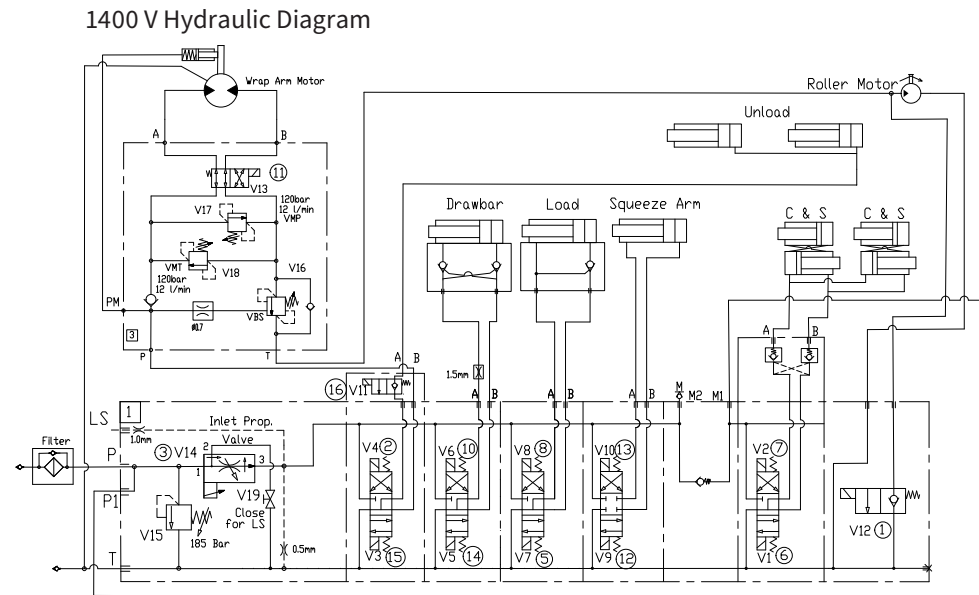

ELECTRO- HYDRAULICS

Description of Hydraulics

The Control Valve uses a 'Proportional Master Valve system; therefore to operate any function the master valve plus the service valve for that function is powered. The proportional master valve allows the volume of oil entering the control valve to be changes for different functions, thus allowing the speed of these functions to be changed by the controller, for example of the wrapping arm speed. during wrapping. For troubleshooting purposes, it is useful to note on the control valve that, energizing a solenoid on top of the valve gives pressure out the bottom port of that section on valve and vice versa.

Setting for different tractor hydraulic systems, Open, Closed and LS.

The 1400 hydraulic system can be set up for tractors with Open, Closed Center and Load Sensing Hydraulics.

Open Centre Hydraulics

Most tractors have a hydraulic system that gives a continuous output which flows through the valve on the machine and back to the tractor when no function is operating (Open center). The TANCO AUTOWRAP 1400 is set-up for open centre on leaving the factory.

Close Centre Hydraulics

Some tractors (John Deere) have a hydraulic system that require the valve on the machine to allow no flow when no function is operating (Closed Center). The 1400 hydraulic system is configured for Closed Centre hydraulics by setting the Closed Centre setting in the Technical Setup of the controller to ON.

Load Sensing Hydraulics.

Many modern tractors have highly efficient Load Sensing hydraulics systems. With this the tractor only delivers the volume of oil required by the machine.

To configure the 1400 valve for LS hydraulics an addition pipe is fitted to the LS port on the control valve. This pipe is connected to the LS signal port on the tractor so oils is sent to the machine when required.

Also for LS V14 is fully closed (as for closed center hydraulics).

To change back to Open Centre, Open valve V14 and let the LS signal pipe disconnected.

ELECTRO- HYDRAULICS

Valve Electrical Connections

- Electrical Leads
- Valves

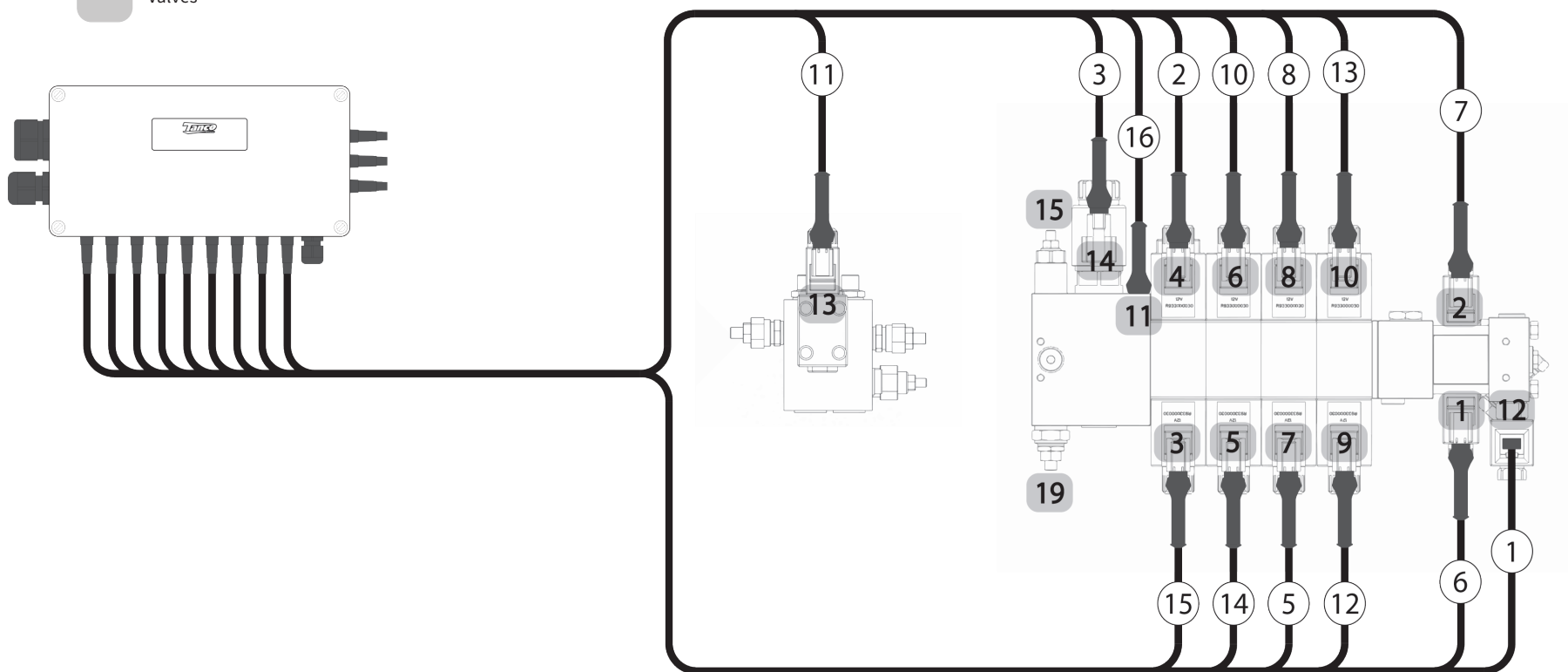

ELECTRO- HYDRAULICS

Valves 1 to 13 are 12 V Electrical Solenoid Valves, their functions are as follows;

Valve V1- Cutter Open (Valve lead 6)

This valve opens the film cutter. To prevent the Cutter creeping closed, there is a load holding valve incorporated into the valve section.

Valve V2- Cutter Close (Valve lead 7)

This valve closes the film cutter. To prevent the Cutter creeping open, there is a load holding valve incorporated into the valve section.

Valve V3 – Tip Return (Valve lead 15)

This valve raises the tipping frame back to the working position.

Valve V4 - Arm Rotate (Valve lead 2)

This valve powers the wrap arm and table rollers.

Valve V5- Drawbar Out (Valve lead 14)

This valve moves the drawbar out to the working position.

Valve 6 – Drawbar In (Valve lead 10)

This valve moves the drawbar to the transport position.

Valve V7 – Load Arm Down (Valve lead 5)

This valve lowers the front loading frame.

Valve V8 – Load Arm Up (Valve lead 8)

This valve raises the front loading frame

Valve V9 – Squeeze out (Valve lead 12)

This valve opens the squeeze arm.

Valve V10 - Squeeze Out (Valve lead 13)

This valve opens the Squeeze arm.

Valve VV11- Roller Half Speed (Valve lead 16)

This valve lowers the tipping frame.

Valve V12- Tip Down (Valve lead 1)

This valve is normally closed; it is pulsed open and closed to give half speed on the table rollers when the film break sensor detects that one film has broken.

Valve V13- Arm Reverse (Valve lead 11)

This valve is powered with Valve V4 to reverse the wrapping arm. It is mounted on the Tower Block.

Valve V14- Master Valve (Proportional) (Valve lead 3)

This is the proportional master valve is in the inlet section. It is activated for all functions, it gets a varying PWM % signal from the controller to control the speed of each function. Its' settings are adjustable in the Technician Setup on the controller.

Valve V15 - Main Relief Valve

The hydraulic system is equipped with a safety relief valve, which is preset to 185 bar. If this pressure is exceeded it opens and allow the oil from the pressure port to the tank port of control valve.

Valve V19 - Load Sensing Valve

This valve is factory set in the opened position for operating with Open Centre but is closed (5mm allen key and 17mm Spanner) for operating with Load Sensing Hydraulics.

Valves 16,17,18 are on the Tower Block, their functions are as follows;

Valve 16 - (VBS) Brake Valve.

This is a pilot operated (8:1 Ratio) Load Holding Valve on the outlet side of the wrap arm motor. It opens when the wrap arms are moving and closes to stop the arms in an emergency stop and when parked.

Valve 17 - (VMP) Cross Line Relief Valve Forward

This valve limits the max. torque of the wrapping arm. If the inlet pressure exceeds the set value, it relieves the oil across to the outlet side of the motor. It is adjusted so that the pull force on the far end of the arm is approximately 35 KG. If it is set too high acceleration at the beginning of wrapping will be very sharp.

Valve 18 - (VMT) Cross Line Relief Valve Reverse

This valve ensures a gradual stop for the wrap arm by limiting the pressure on the outlet side of the motor. If the pressure exceeds the set value, it relieves the oil across to the inlet side of the motor.

IMPORTANT:

Valves 15 to 18 have been carefully set in the factory. Incorrect adjustment of these may cause damage to the machine. Always ensure that trained personnel only adjust the settings of these valves.

Pressure Test Point

There is a pressure test point on the underside of the Control Block.

ELECTRO- HYDRAULICS

Wrap Arm Electrical Connections

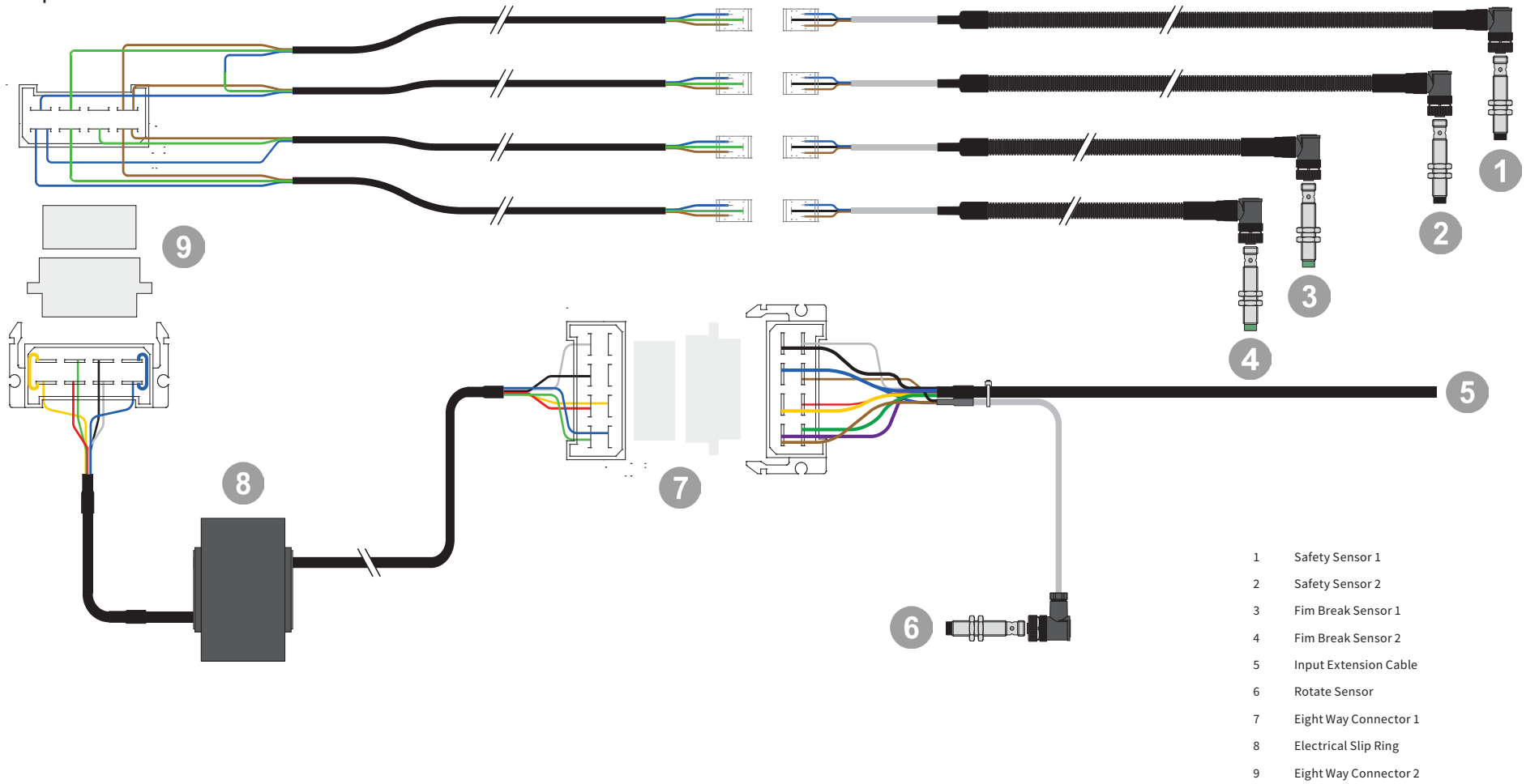

ELECTRO- HYDRAULICS

Junction Box Wiring

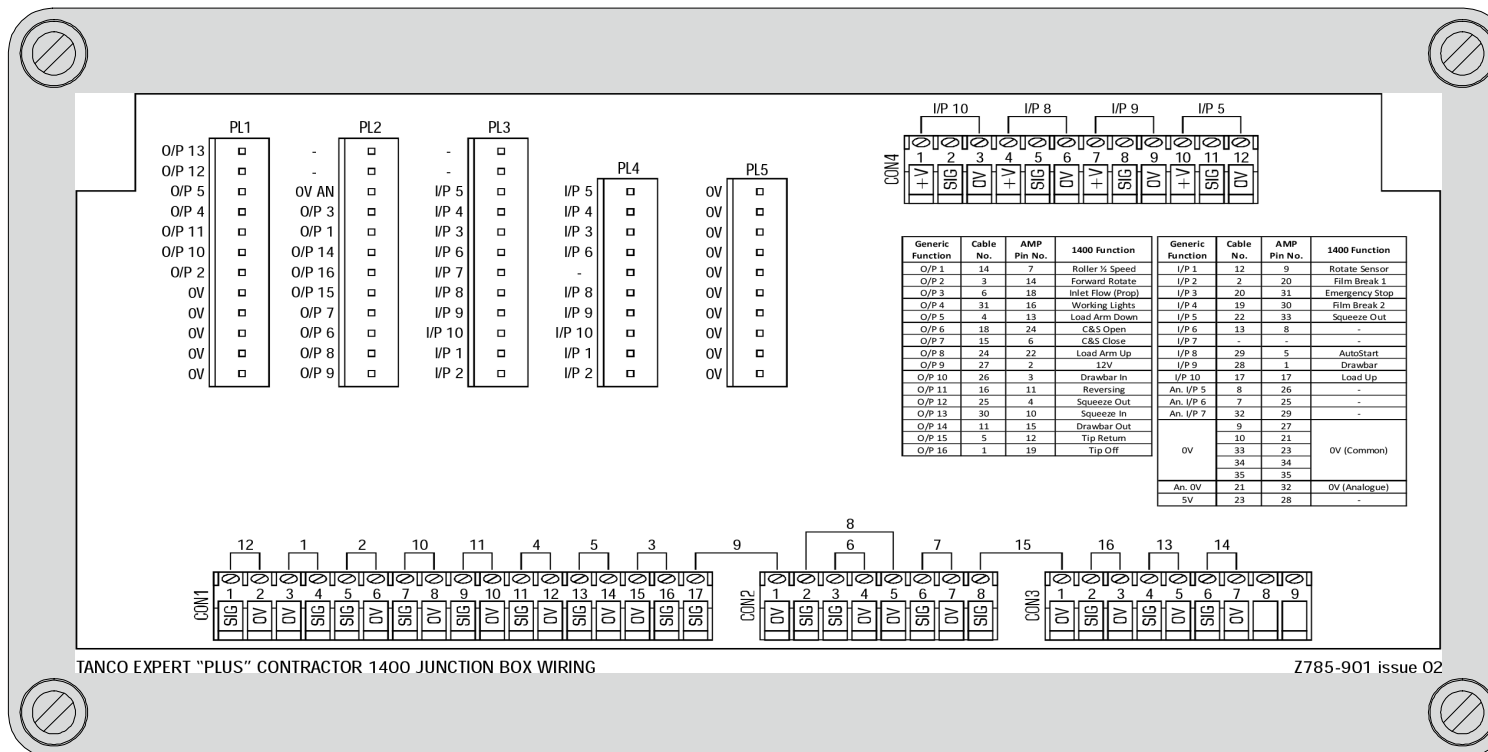

TANCO EXPERT "PLUS" CONTRACTOR 1400 JUNCTION BOX WIRING

Z785-901 issue 02

09 TROUBLESHOOTING & MAINTENANCE

Check Points Prior to Troubleshooting

There are some general check points that must be examined first if something is wrong with the machine. There are three basic assumptions that must be fulfilled for the machine to function properly;

1. The oil pressure from tractor should be 190 bar.
2. The return flow of oil must be as free as possible, max. 10 bar counter pressure.
3. Enough electric power to all functions.

TROUBLESHOOTING & MAINTENANCE

Oil Pressure

To check the oil pressure into the machine put a pressure gauge in line on the feed hose or there is a standard test point on the underside of the Control Valve. Engage the oil flow from the tractor hold the L2 cutter close valve to bring the system up to full pressure. The gauge should read 190 Bar.

Oil Flow

The amount of oil that the tractor delivers should be minimum 30 liters/minute for satisfactory operation of the machine, but it is recommended that it is 35 liters/minute. Note: (Max. allowed oil amount is 60 liters/minute). Ensure that oil level in tractor's hydraulic system is correct and tractor's oil filter is changed regularly.

Return Pressure

Max. allowed return pressure is 10 Bar, we recommend "free return" directly to the tank. Check the return pressure by putting a pressure gauge in line on the return line.

High return pressure affects the operation of the control valves, the wrap arm parking brake and motor seals. It also reduces the hydraulic pressure available to operate the machine.

Electrical Connection

The 1400V requires a 12V electric supply with a current capacity of up to 15 Amp. It should be connected to the tractor with the 3 pin Euro socket on the wiring loom, see controller section of this manual for further details. The controller displays the voltage on the right-hand side of the display.

Note on the wiring loom power cable: brown wire is 12V(+), Blue wire is 0V(-). Polarity is important.

If the controller does not power up:

- Check the power to the tractor's Euro socket.
- Check that fuse on the power cable to the machine, it is fitted with two 15Amp fuses also the power cable to the controller also has two 15Amp fuses.

If the voltage drops below 11V while the machine is running:

- Check that the pins on the euro plug and socket are clean and making good contact.
- Check the battery and charging system on the tractor especially if operating with working lights on.

Procedure of Troubleshooting

If the machine fails to operate correctly it must be determined if the problem is Hydraulic, Mechanical or Electrical.

Solenoid Valves

When checking if the Solenoid valves are receiving electric power, you do this in the following way:

1. Unscrew the nut that holds the solenoid.
2. The solenoid is easy to move without electric power.
3. Push the current function on the remote control. If the solenoid gets power, it will be difficult to move, it "sticks". This is the best and easiest way to check if the solenoid valve is receiving electric power. Another way is to hold a screwdriver up to the magnet. If it "sticks", the solenoid is receiving electric power.

The power supply to the valve can also be measured with a voltmeter, but then the contact must be connected to the solenoid, so it is using power. To have reliable functions, the voltage should not be lower than 11,5 volts, even if the solenoid valve usually works with a little lower voltage.

If the electric supply is in order and one of the functions fails, the reason can be dirt that tightens or prevents the sliding shaft (spool) from moving.

Try to manoeuvre the function manually, by pressing the point of a screwdriver into the end of the valve housing. At the same time the corresponding switch on the control unit MUST be operated to get electric power to the master valve. If the function is working again after this, the dirt may have been pushed out in the oil system and the machine can be operated normally again.

Take care that the machines moving parts, do not cause damage to persons or objects.

TROUBLESHOOTING & MAINTENANCE

Controller Sensor Check (Input Check)

The controller has a diagnostic capability to check the signals coming from the sensors on the machine. Each sensors activates an input to the controller, these are given IP numbers, details of the IP number that connects to each sensor are given in the Lid Label .

To access the Input Check, press the enter arrow 3 times. Then the numbers on the top line indicate the sensors that are active, here sensors no. 1,3,5 and 6 are active.

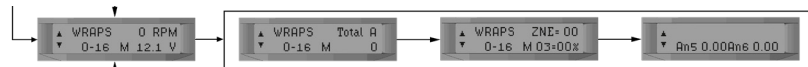

The controller requires the inputs from the sensors for many operational and safety functions on the machine, this diagnostic tool is very useful.

The oil pressure is very high when engaged from tractor

- Check that the hydraulic couplings are connected correctly to the tractor, the feed and return hoses are in the correct positions.
- If oil has been fed in the return pipe it can cause a lock between the quick coupling and the check valve on the end of this pipe. The nipple on the quick coupling will be solid in this case. To relive this the quick coupling must be loosened to relieve the pressure.

The Cutter will not Hold the Film

- Is the cutter closing fully, if not increase the Cutter Close Time 2. (Technician Setup on controller)
- If the cutter is creeping open:
- There may be dirt in the load holding valve, open and close the cutter a few times to try to clear this. If this doesn't solve the problem it will require a technician to check the valve.
 - If the problem develops over time then it may be due to seal wear in the cutter arms. They will require replacing.

The Wrapping Arm will not Rotate

- Check error messages on the controller: 'SQUEEZE OUT', squeeze arm must be in the fully out position for wrapping to start. 'SAFETY' if the safety arm has tripped.
- Are the hydraulics coming under pressure, if not check hydraulic and electric connections? If the hydraulics are coming under pressure then it is like to be a problem with the electrical supply to the control valve, this is best dealt with by an experienced technician.

The Hand Controller will not Operate any of the 4 buttons

In the Operator Setup, the Remote Type (Menu no.4.41) may be set to RF, if so, change to IR.

If some buttons operate then the wires may be damaged in the connector to the controller, this can happen if the controller falls from the cab window.

Periodic Maintenance

Bearings

All ball-bearings are packed with grease, and do not need any more maintenance.

Pre-Stretchers

If the machine is in daily use, the Gears under the plastic cover on the dispenser should be greased when needed.

Cutters / Film Holders

The cutter / film holder is pre-adjusted from the factory and does not need further adjustments. When replacing spare parts, it is necessary to adjust it. The springs for the U-shaped slot shall be adjusted so that they are almost completely squeezed together when the cutter-arm is all down.

Cleaning

The machine should be cleaned and oiled regularly and at the end of the wrapping season. When using high pressure washing apparatus, care must be taken with the electrical installation. Also make sure that water is not sprayed directly into the bearings, etc. Keep the control box protected from rain and water. If necessary use compressed air to dry electrical components.

Hydraulic Cylinders

Make sure that all hydraulic cylinders are closed when storing the machine.

Quick Couplers

Ensure that the quick couplers are kept clean and apply the dust caps after use.

Storage

The machine should be parked on a dry place during the closed season.

Oil Filter

The oil filter must be changed once a year.

TROUBLESHOOTING & MAINTENANCE

Lubrication

The table below outlines the recommended lubrication requirements for components on the 1400;

No.	Component	Type	Intervals
1	Drawbar Ram	Grease	50hrs
2	Table Up Ram	Grease	10hrs
3	Table Tip Ram	Grease	10hrs
4	Squeeze Arm	Grease	10hrs
5	Cut & Tie Shafts	Copper Grease	50hrs
6	Dispenser Gears	Oil	50hrs
7	Drawbar Pivot	Grease	50hrs
8	Table Pivots	Grease	50hrs
9	Load Arm Pivot	Grease	50hrs

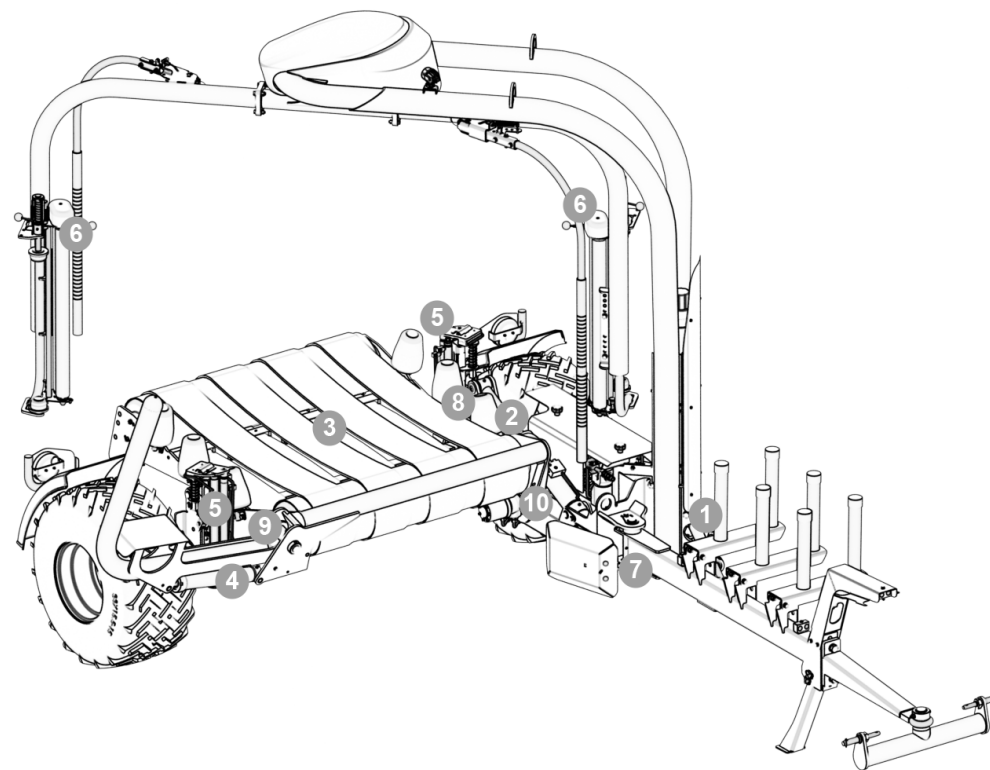

10 GUARANTEE / DECLARATION OF CONFORMITY

GUARANTEE / DECLARATION OF CONFORMITY

GUARANTEE

Subject to hereunder provided, the sellers undertake to correct either by repair or at their election by replacement any defect of material or workmanship which occurs in any of its goods within twelve months after delivery of such goods to first user, with the exception of contractors or commercial users when warranty period is six months.

In respect of Autowraps the warranty period is for 12 months or 8000 bales, whichever occurs first.

The term goods when used in this document means the article or articles described in invoices as sold by the sellers but does not include equipment or proprietary parts or accessories not manufactured by the sellers. The sellers, however, undertake to pass on so far as they legally can to the first user the benefit of any warranty given to the sellers by the suppliers of such equipment, parts or accessories.

This understanding shall not apply to:-

- (a) Any goods that have been sold by the first user.
- (b) Any goods which have been injured by unfair wear and tear, neglect or improper use.
- (c) Any goods the identification marks of which have been altered or removed.
- (d) Any goods that have not received the basic normal maintenance such as tightening of bolts, nuts, tines, hose connections and fittings and normal lubrication with the recommended lubricant.
- (e) The use of any product on tractors exceeding the recommended horsepower.
- (f) Any goods that have been altered or repaired other than on instruction or with the written approval of the seller or to which any part not manufactured or having written approval by the sellers have been fixed.
- (g) Any second-hand goods or parts thereof.

Any allegedly defective part or parts returned to the seller must be sent carriage paid. No claim for repair or replacement will be entertained unless upon discovery of the alleged defect written notification is sent to the Sellers giving, at the same time, the name of the Buyer from whom the goods were purchased and the date of purchase, together with the full details of the alleged defect and the circumstances involved, also the serial number of the machine etc.

The sellers shall be under no liability to their Buyers and first or subsequent users of their goods or to any other person or persons for loss or damage howsoever arising in respect of either personal injuries or for arising out of, or in any other way connected with or arising from the manufacture, sale, handling, repair, maintenance, replacement or use of its goods or the failure or malfunction of any of its goods.

Representation and/or warranties made by any persons (including Buyers and employees and other representatives of the Seller) which are inconsistent or conflicting with these conditions are not binding upon the sellers unless given in writing and signed by a director of sales.

CLAIMS

If you wish to make a claim under the guarantee: 1: Immediately, stop using the machine.

2: Consult with your Tanco dealer (supplier). He/She can download a warranty claim form on-line. This should be filled out and e-mailed to distributor and forwarded to relevant contact person in Tanco. Please ensure all relevant information is included on this form

3: Consult with your Tanco dealer (supplier) and have them forward your claim and the damaged item to Tanco.

GUARANTEE / DECLARATION OF CONFORMITY

EC DECLARATION OF CONFORMITY

Manufacturer: Tanco Autowrap Ltd.
Bagenalstown
Co. Carlow
IRELAND

CERTIFIES THAT THE FOLLOWING PRODUCT:
TANCO AUTOWRAP
MODEL: 1400 V
SERIAL NO:

To which this declaration relates, corresponds to the essential requirements of the Directive 2006/42/EC.

To conform to these essential health and safety requirements, the provisions of the following harmonized standards were particularly considered: ISO 12100, EN 294, prEN 703, EN ISO 13857, EN ISO 4254 - 1, prEN 982.

DATE: 01/10/2017

Signed:



Con Hourihane, Technical Manager





CONTACT

Address

Tanco Autowrap Ltd.
Royal Oak Road,
Bagenaltown
Co. Carlow
Ireland

Phone & Online

Phone: + 353 59 972 1336
Email: info@itanco.com
Website: www.itanco.com
Support: tanco.zendesk.com