



TANCO AUTOWRAP
1510 / 1514 2004
OPERATORS HANDBOOK
WD66-1510 / 1514-M1003

Tanco Autowrap Ltd.
Royal Oak Road
Bagenalstown
Co. Carlow
Ireland

Tel.: +353 (0)5997 21336
Fax: +353 (0)5997 21560
E-Mail: info@tanco.ie
Internet: www.tanco.ie



GUARANTEE

Subject to hereunder provided, the sellers undertake to correct either by repair or at their election by replacement any defect of material or workmanship which occurs in any of its goods within twelve months after delivery of such goods to first user, with the exception of contractors or commercial users when warranty period is six months. In respect of Autowraps the warranty period is for 12 months or 8000 bales, whichever occurs first.

The term goods when used in this document means the article or articles described in invoices as sold by the sellers but does not include equipment or proprietary parts or accessories not manufactured by the sellers. The sellers, however, undertake to pass on so far as they legally can to the first user the benefit of any warranty given to the sellers by the suppliers of such equipment, parts or accessories.

This understanding shall not apply to:-

- (a) Any goods that have been sold by the first user.
- (b) Any goods which have been injured by unfair wear and tear, neglect or improper use.
- (c) Any goods the identification marks of which have been altered or removed.
- (d) Any goods that have not received the basic normal maintenance such as tightening of bolts, nuts, tines, hose connections and fittings and normal lubrication with the recommended lubricant.
- (e) The use of any product on tractors exceeding the recommended horsepower.
- (f) Any goods that have been altered or repaired other than on instruction or with the written approval of the seller or to which any part not manufactured or having written approval by the sellers have been fixed.
- (g) Any second-hand goods or parts thereof.

Any allegedly defective part or parts returned to the seller must be sent carriage paid. No claim for repair or replacement will be entertained unless upon discovery of the alleged defect written notification is sent to the Sellers giving, at the same time, the name of the Buyer from whom the goods were purchased and the date of purchase, together with the full details of the alleged defect and the circumstances involved, also the serial number of the machine etc.

The sellers shall be under no liability to their Buyers and first or subsequent users of their goods or to any other person or persons for loss or damage howsoever arising in respect of either personal injuries or for arising out of, or in any other way connected with or arising from the manufacturer's sale, handling, repair, maintenance, replacement or use of its goods or the failure or malfunction of any of its goods.

Representation and/or warranties made by any persons (including Buyers and employees and other representatives of the Seller) which are inconsistent or conflicting with these conditions are not binding upon the sellers unless given in writing and signed by a director of sales.

CLAIMS

If you wish to make a claim under the guarantee:

- 1: Immediately, stop using the machine.
- 2: Consult with your Tanco dealer (supplier). He/She can download a warranty claim form on-line. This should be filled out and e-mailed to distributor and forwarded to relevant contact person in Tanco. Please ensure all relevant information is included on this form
- 3: Consult with your Tanco dealer (supplier) and have him forward your claim and the damaged item to Tanco.



1514-1510 square & round bale wrapper

CONTENTS	PAGE
1.0 INTRODUCTION	4,5
2.0 SAFETY PRECAUTIONS	6-9
3.0 GENERAL INFORMATION ON BALE WRAPPING	11,12
4.0 SETTING UP / MOUNTING OF THE MACHINE	12-17
5.0 EMERGENCY STOP	18
6.0 FITTING ROLL OF FILM	19
7.0 CONTROLLER MANUAL	20-25
8.0 SPEED SETTING OF THE WRAPPING ARM	26
9.0 ADJUSTING THE OVERLAP	26
10.0 OPERATION INSTRUCTION	27-29
11.0 SPECIAL INSTRUCTIONS FOR TWIN	30
12.0 PERIODIC MAINTENANCE	31
13.0 ELECTRIC CIRCUIT	33-34
14.0 HYDRAULICS	34-41
15.0 CHECK POINTS BEFORE TROUBLE SHOOTING	42
16.0 PROCEEDURE FOR TROUBLE SHOOTING	43
17.0 TROUBLE SHOOTING	44-47
18.0 HYDRAULIC CHART	48
19.0 WARRENTY CLAIM FORM	49
20.0 DECLARATION OF CONFORMITY	50

1.0 INTRODUCTION.

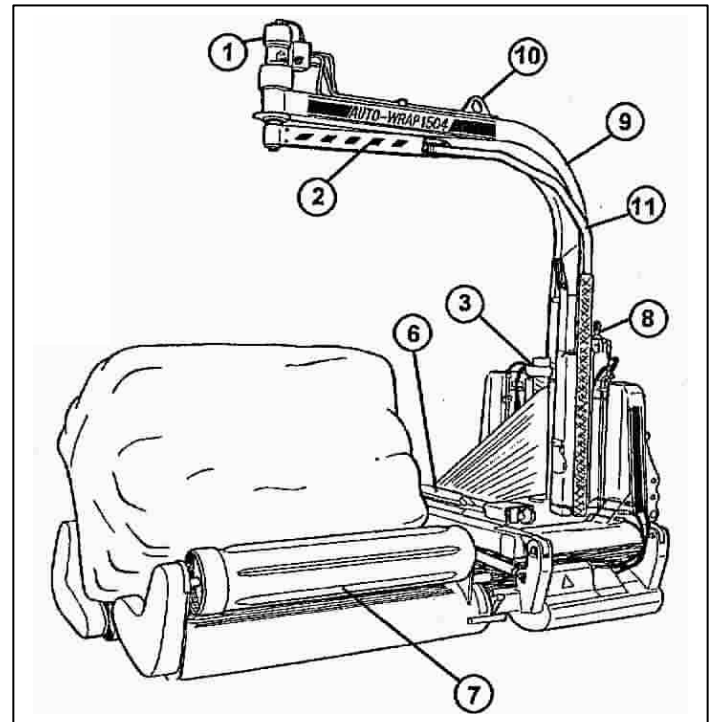
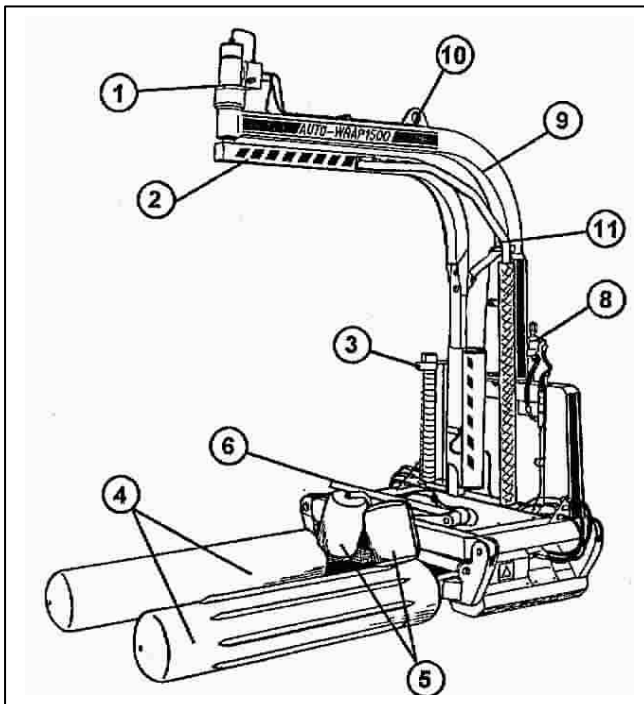

1. Wrapping arm motor
2. Wrapping arm
3. Pre-stretcher
4. Rollers
5. Support rollers
6. Cutter
7. Special rollers for square bales
8. Sped control
9. Fixed arm
10. Lifting point
11. Safety arm
12. Cutter housing

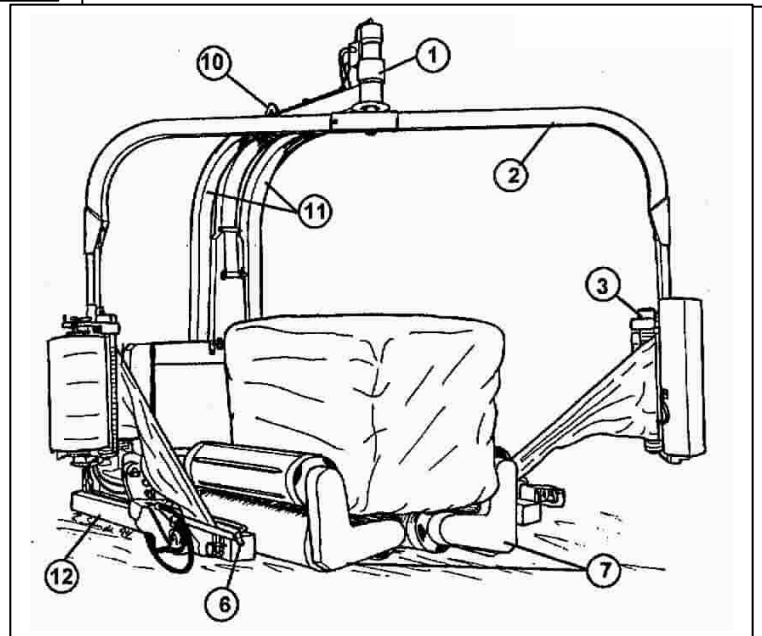

TANCO AUTOWRAP LTD. congratulates you with the choice of an AUTOWRAP bale wrapping machine. We are certain you will be satisfied with the machine, and that you will have the pleasure of your investment for many years.

The TANCO AUTOWRAP bale wrapping machine has more features than any other bale wrapping machine available. TANCO AUTOWRAP can pick up the bale, wrap and stack them without the operator leaving the tractor cab. This system is protected by patent TANCO AUTOWRAP Ltd almost world wide.



Tanco Autowrap 1514-1510
Operator's manual

TANCO AUTOWRAP is hydraulically driven by the tractors hydraulic system, and is controlled from the tractor cab by a remote control unit. The machine can either be mounted to three point linkage, front mounted with optional attachment brackets to the tractors front-loader or on a wheel loader. Then it's possible to stack the bales upon each other.

TANCO AUTOWRAP 1510 is designed to wrap bales of grass, hay or straw, with nominal diameter of 4-6 ft. (120 -180 cm), and weights up to lbs. (1500kg).

The TANCO AUTOWRAP 1514 is essentially the same machine as the TANCO AUTOWRAP 1510, but with a patented special mounting for the rollers so that square bales can be wrapped.

The TANCO AUTOWRAP 1514 can wrap both square and rectangular bales, from 60 x 60 to 120 x 120 x 150 cm. It can take bales of up to 1,200 kg. It can also wrap round bales of up to ø1200 mm.

Both the TANCO AUTOWRAP 1510 and 1514 can also be supplied as TWIN models, i.e. the machines are equipped with two film stretching units and two cutters. This gives the machines a significantly increased capacity.

The machine is developed and has been improved since the beginning in 1986, and is now a very reliable and safe machine with high security built in.

This manual is meant to explain how TANCO AUTOWRAP is prepared, mounted, used and how it works, and shall together with the spare part's list be a reference for maintenance and troubleshooting. So take good care of the books, they are a part of the machine.

Read carefully through this manual, and specially chapter 2.0, safety instructions, before starting the machine, and follow the instructions thoroughly. If problems should occur, check with chapter 17.0, and try to find out what is wrong. Ask your dealer for advice before you make the problem worse than it is. See also chapter 19.0, conditions of warranty.

TANCO AUTOWRAP	1510	1514	1510-1514 TWIN
Height in working position	2820 mm (9'3")	2960 mm (116")	2960 mm(116")
Width, min. / max.	1520 / 3000 mm (5' / 10')	1520 / 3000 mm (5' / 10')	2440 / 3215 mm
Length, min. / max.	2450 / 3000 mm (8' / 10')	2450 / 3000 mm (8' / 10')	2540 / 3425 mm
Weight	780 kg (1720 lbs)	780 kg (1720 lbs)	950 / 1100 kg
Wrapping arm speed, recommended	22 rev. per minute	22 rev. per minute	22 rev. per minute
Wrapping arm speed, max.	27 rev. per minute	27 rev. per minute	27 rev. per minute
Bale size, max.	ø1800 mm (6')	ø1800 mm (6')	Same as std. machine
Bale weight, max.	1500 kg (3300 lbs)	1200 kg (2650 lbs)	Same as std. machine
Capacity	Approx. 25 bales per hour	Approx. 25 bales per hour	Approx. 40 bales per hour
Pre-stretcher	500 / 750 mm (20" / 30")	500 / 750 mm (20" / 30")	500 mm (20")
Hydraulic connection	1 single work. +free return	1 single work. +free return	1 single work. +free return
Oil pressure / amount, min.	180 bar / 25 litres/minute	180 bar / 25 litres/minute	180 bar / 25 litres/minute
Oil amount, max.	60 litres per minute	60 litres per minute	60 litres per minute
Counter pressure, max.	10 bar	10 bar	10 bar
Electric connection	12 V DC	12 V DC	12 V DC

TANCO AUTOWRAP Ltd can change the construction and/or technical specifications without warning and without rights to changes on already delivered products.

© Copyright. All rights reserved. Any copying and reproduction of this manual is not permitted without permission from TANCO AUTOWRAP Ltd

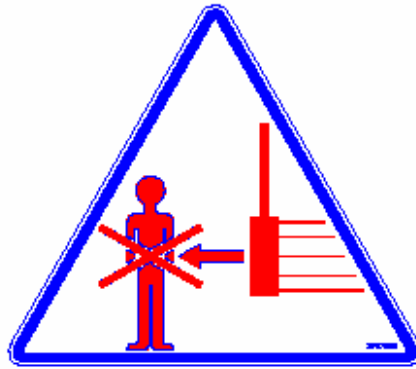

2.0 SAFETY PRECAUTIONS.

TANCO AUTOWRAP Ltd does not take the responsibility for damages that may occur on machine, persons or other equipment, because of the machine NOT being used as described in this manual, or because of the safety precautions NOT being followed.

2.1 SAFETY EQUIPMENT.

Before using the machine, make sure that all guards and covers are securely fitted. The machine must not be operated if a function does not work as described later in this manual. (See chapter 2.5).

The Auto Wrap 1510 / 1514 / TWIN models are equipped with an "EMERGENCY STOP" on the wrapping arm. This device stops all functions instantly, but is by definition not an emergency stop, because it does not interrupt the feed. Nevertheless it has an equivalent function, so we have decided to call it an EMERGENCY STOP in this book.

2.2 BECOME FAMILIAR WITH THE OPERATIONS OF THE MACHINE.

If you are unsure how to operate the machine properly, either use of or maintenance to your AutoWrap, please contact your AutoWrap dealer.

2.3 ADJUSTMENTS' / MAINTENANCE.

Turn off the tractor and discharge the oil pressure before performing any adjustment or maintenance on the machine. Remember that a well-maintained machine is a safe machine.

2.4 IMPORTANT!

**ALWAYS MAKE SURE THAT NOBODY IS INSIDE
THE MACHINE'S WORKING AREA WHEN IT'S IN USE.
SAFETY DISTANCE IS 5 METRES**

THE MACHINE MUST NEVER BE OPERATED BY PERSONS WHOM DOES NOT KNOW ENOUGH ABOUT HOW TO SAFELY OPERATE THE MACHINE, OR BY PERSONS UNDER 16 YEARS OF AGE.

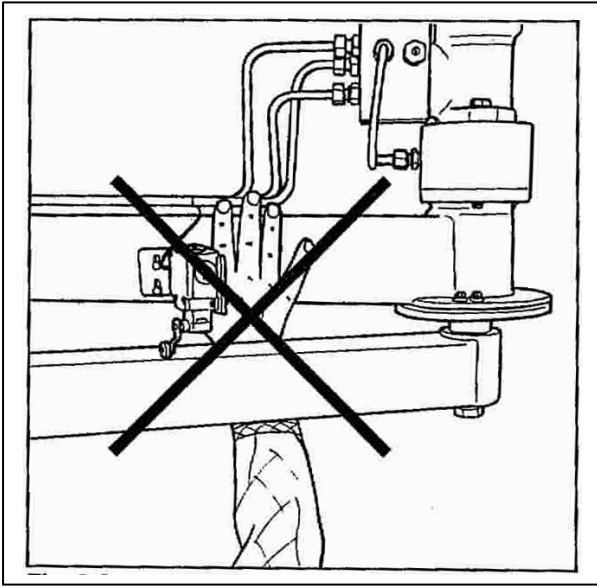

2.5 DANGEROUS AREAS.

TANCO AUTOWRAP LTD. has given the safety to the operator the highest priority, but it is still impossible to secure oneself of every danger area on the machine. Therefore we will now go through some of the dangers that can occur when using the TANCO AUTOWRAP Ltd bale wrapper

1. IMPACT OF THE WRAPPING ARM.

During the wrapping process the arm rotates with a speed of 20-27 revolutions per minute around the bale. On the arm there is a Dispenser unit with a plastic roll mounted. The speed of this can give a person serious injuries if one comes to close to the working area of the wrapping arm. To reduce this danger we have mounted an emergency stop* device on the wrapping arm, this stops all movement instantly when someone comes in the way of it. It

is very important that this protection always works and that it should not under any circumstances be disconnected.

(See more about the emergency stop* in chapter 5.0).

2. SQUEEZE-DANGER BETWEEN THE MAIN FRAME AND THE WRAPPING ARM.

As earlier explained, we have a wrapping arm with a dispenser and a plastic roll. Once every time around this wrapping arm passes the main frame. There is a squeeze danger if a person stands too close to the main frame when the wrapping arm passes. The distance between the main frame and the wrapping arm is not large enough for a person. Between the pre-stretcher and the bottom frame there can also be a squeeze danger.

3. SQUEEZE-DANGER BETWEEN THE STATIONARY AND THE WRAPPING ARM.

During the main wrapping process the wrapping arm moves around a stationary arm. Every time the wrapping arm passes the stationary arm, there is a squeeze danger that can be dangerous for the fingers. The distance between the stationary and the wrapping arm is between 25-40 mm. (See fig. 2-2).

4. SQUEEZE DANGER BETWEEN THE ROLLER ARMS AND THE MAIN FRAME.

When loading a bale, the roller arm moves in underneath the main frame. There is a squeeze danger for feet and fingers. Keep therefore fingers and feet away from this area.

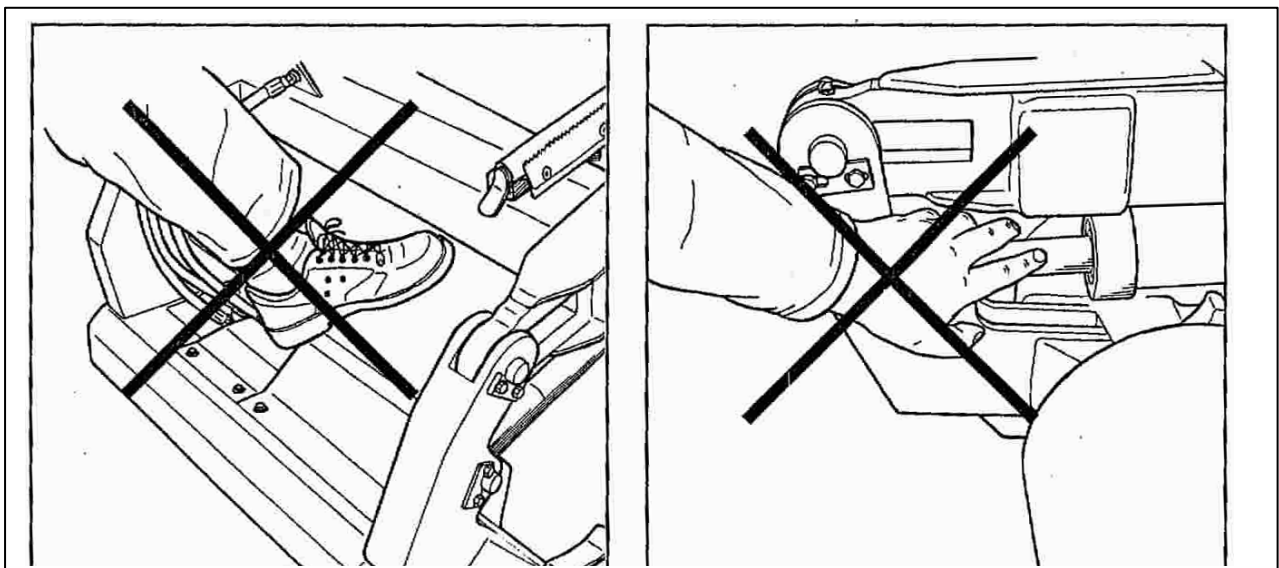

5. **SQUEEZE DANGER BETWEEN HINGE ON THE ROLLER ARMS AND MAIN FRAME.**
When loading a bale there is also a squeeze danger between the hinge-points on the roller arms and the main frame, and between the width cylinders and the main frame. (Fig. 2-4). Keep hands away from these areas.

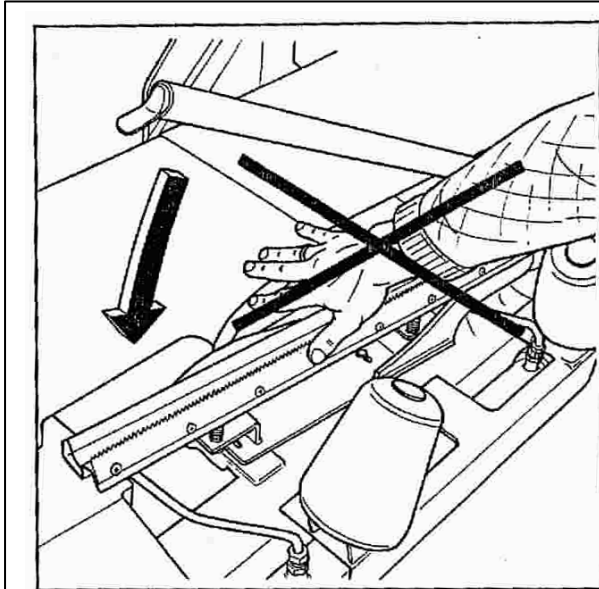

Fig. 2-5

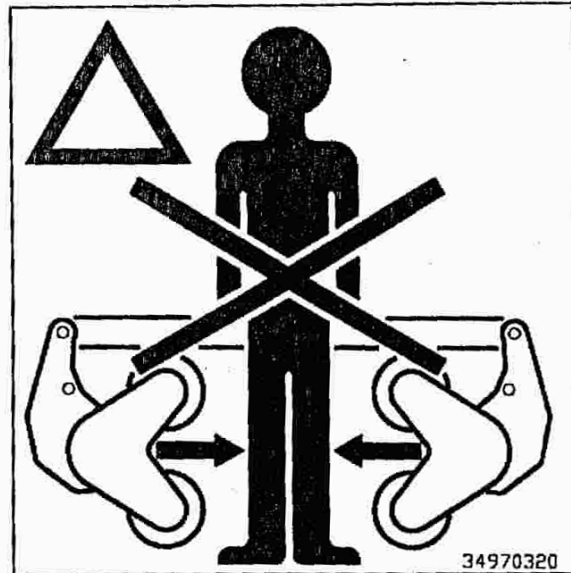
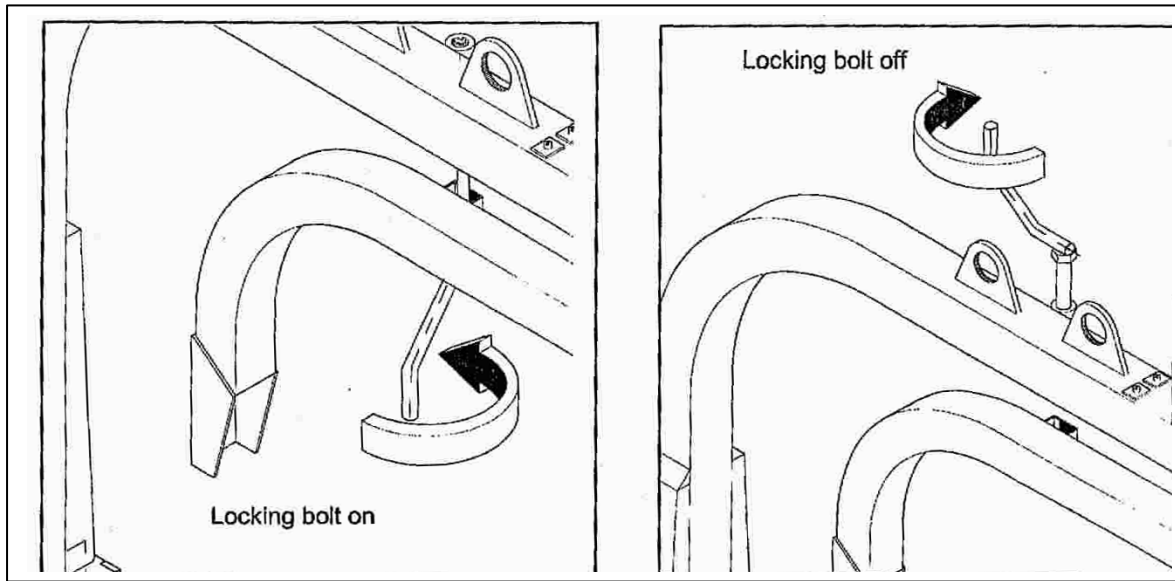

Fig. 2-6

6. **SQUEEZE DANGER CAUSED BY PLASTIC AUTOMATION.**
At the end of the wrapping process the plastic shall be perforated and held tight until the start of the next wrapping process. When the cutter arm moves down to lock the plastic, there can occur a squeeze danger between the cutter arm and the cutter holder. The cutter blade that perforates the plastic is very sharp, so keep hands away from the cutter. (See fig. 2-5).
Always put the security cover over the cutter blade when the machine is not in use.
7. **SQUEEZE DANGER BETWEEN THE ROLLERS ON AUTO WRAP 1514 / TWIN.**
When the rollers on the 1514 machine are moved all together, there is not enough space for a person between the rollers. Here it can occur a squeeze danger, so make sure that nobody is between the rollers when they are moved together. (See fig. 2-6).



2.6 LOCKING THE WRAPPING ARM.

When the machine is not in use, make sure the locking bolt for the wrapping arm is mounted. If the bolt is not mounted, the wrapping arm and/or the machine could be damaged during transport. (See fig. 2-7). For TWIN machines, see also section 2.10.

2.7 THREE POINT MOUNTING.

When the machine is mounted in the three point linkage, make sure that the stabilizing links are tightened-up so there is no sideways movement.

2.8 FRONT MOUNTING.

Ensure that the machine you intend use the machine on has sufficient capacity to lift the wrapper with a bale loaded.

If the machine is mounted on the front loader there must be a counterweight in the three point linkage. It must be large enough to give the tractor good stability.

Connecting heavy working implements often has an overall negative effect on the tractor's driving and braking capacity.

2.9 TRANSPORTING.

When transported on a public road there are certain safety measures that must be taken:

1. Move the wrapping arm in under the davit in the transport position by pressing  "WRAP SLOW" in manual mode and keeping it pressed in.
2. For locking and disengaging the wrapping arm during transportation, ensure that the locking bolt for the wrapping arm is fitted. (See section 2.6 and fig. 2-7.)
3. Move the main rollers completely together.
4. Always transport the machine in the lowest possible position.
5. Make sure that the machine do not cover the tractors lights. If necessary, mount extra lights.
6. Make sure that at least 20% of the tractor's total weight is on the steering wheels.
7. If the machine is front-mounted, it's necessary to balance the weight with a counterweight mounted to the three-point linkage.

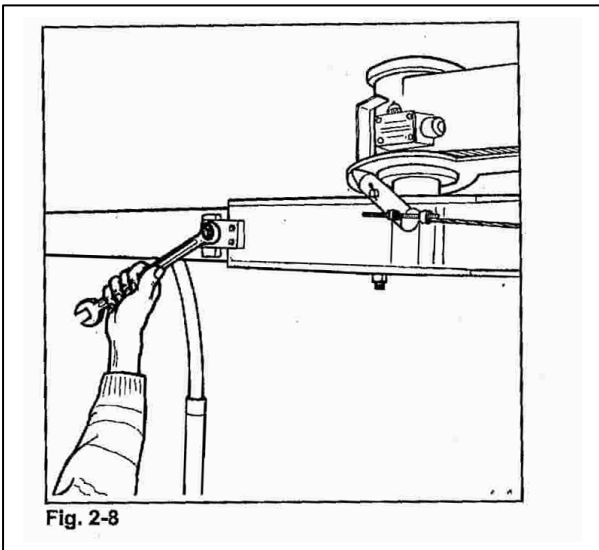

2.10 SPECIAL INSTRUCTIONS FOR AUTO WRAP 1510 / 1514 TWIN

These machines must be prepared for transport in a slightly different way:

1. Move the main wrapping arm in under the davit in the transport position by pressing  "Wrap slow" and keeping it pressed in.
2. For locking and disengaging the wrapping arm during transportation, ensure that the locking bolt for the wrapping arm is fitted. (See section 2.6 and fig. 2-7.)
3. Loosen the fixing screws for the locking plate which secures the second wrapping arm in the working position. Then swing the arm in towards the davit. (See fig. 2.8.)
4. To reduce the transport width of the TWIN machines, at the same time preventing the secondary arm from accidentally swinging out to the side during transportation (see fig. 2.9), each cutting beam is put in the transport position by holding the beam by the edge and lifting it upwards and inwards by hand. Using a special grooved slot at the back end of the mounting point, the cutting beam locks automatically in the raised transport position when the beam is dropped to its lower position once more at the back. (See fig. 2.10.) (See also sections 3 to 8 for the standard machines)

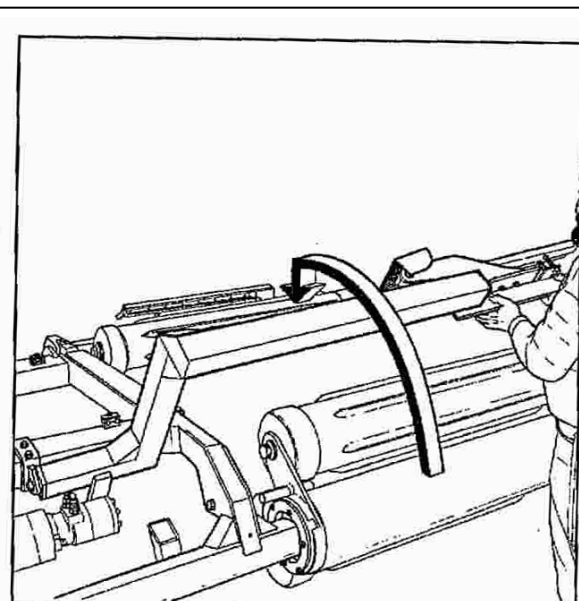
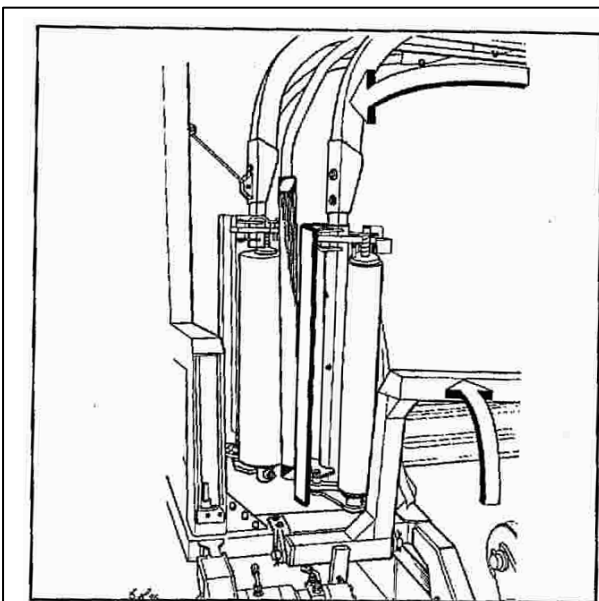



3.0 GENERAL INFORMATION ON BALE WRAPPING.

3.1 THE PRINCIPLE.

The advantages of round/square bale silage are many, and include fewer feed units, a flexible harvesting system, large capacity and the possibility of selling feed units.

In principle, the same fermentation processes occur whether the fodder is placed in a silo or pressed into bales and packed in plastic, i.e. lactic acid fermentation in anaerobic conditions. The oxygen in the bale must be exhausted before fermentation begins.

The grass should be dried to approximately 30-40% solid content. The solid content can be determined by twisting the grass by hand. If drops of liquid are forced out of the grass, the solid content is less than 25%. Low solid content, (wet grass), can lead to increased butyric acid fermentation if preservatives are not added to the grass. If the solid content is too high, (over 50%), normal fermentation will not take place and there will be enough oxygen in the bale to produce mould fungus.

3.2 THE BALER.

It is vital that the baler produces compact, well-formed bales, as misshapen bales can be difficult to wrap. Baling will also often take longer, thereby increasing the amount of plastic used.

3.3 TYPES OF PLASTIC.

A good type of plastic with good adhesive properties, and which is recommended for bale wrapping, must be used. The thickness of the plastic foil should be at least 25 µ (25/1,000 mm). In order that the plastic tightens sufficiently around the bale, it is stretched before being wrapped, so it is somewhat thinner when it is put on the bale. With short-term storage, (up to eight weeks), it is recommended that bales have a minimum of four layers of plastic at the thinnest points, with at least 52-53% overlap.

For long-term storage, or when the grass is wet when it is wrapped, the bale should have 90-100 µ plastic, (6 layers), and the same amount of overlap. If thinner plastic is used, more layers should be applied. If it is very hot the plastic will be stretched further, and more layers should be applied. It is better to have slightly too much than too little plastic on the bale.

From experience, light plastic produces slightly lower temperatures within the bale, and tends to improve feed quality.

3.4 STORAGE LOCATION.

Care should be taken in finding a suitable location for the storage of bales. The storage location should preferably be prepared before the bales are laid out. An elevation close to well-drained roads is recommended. If the wrapped bales are simply placed on stubble there is a danger of the plastic being pierced. A tarpaulin or a thin layer of sand should therefore be laid where the bales are to be stored over the winter.

Bales should be stored in the shade as far as possible. This reduces the danger of air leakage in the bales. A bale which is stored in sunlight and which therefore undergoes greater swings in temperature "pumps in" a great deal of air in comparison to a bale which is stored in the shade. According to ~'Teknik for Lantbruken' [Technology for Agriculture] in Sweden, a bale which is stored in the shade has only 40% of the air leakage of a bale which is stored in sunlight.

3.5 STACKING / PROTECTION.

If bales are hard and well formed, they can be stacked vertically, but loose and misshapen bales with low solid content should not be stacked higher than one layer, as this could easily cause deformity and the danger of runoff will be increased.

Bales can also be stored on their sides. The layer of plastic is thicker here, providing greater protection against piercing.

Bales should be covered with a tarpaulin or a fine-mesh net to protect against birds and small rodents. If the plastic is pierced, it must be sealed with weatherproof, hard-wearing tape, preferably under the outermost layer of plastic. Ensure that the hole is adequately sealed.

3.6 The best wrapping results are obtained by...

1. Harvesting the grass early.
2. Drying it out to 30-40% solid content. If there is a danger of rain, bale and wrap the grass anyway.
3. Taking care not to mix any earth in with the grass.
4. Using a baler which produces even, firm babs.
5. Wrapping the bales soon after baling, never later than two hours afterwards.
6. Using a good type of plastic and six layers of plastic. This removes the need to use preservatives.
7. Storing bales in the shade to reduce the danger of air leakage.

4.0 SETTING UP / MOUNTING OF THE MACHINE.

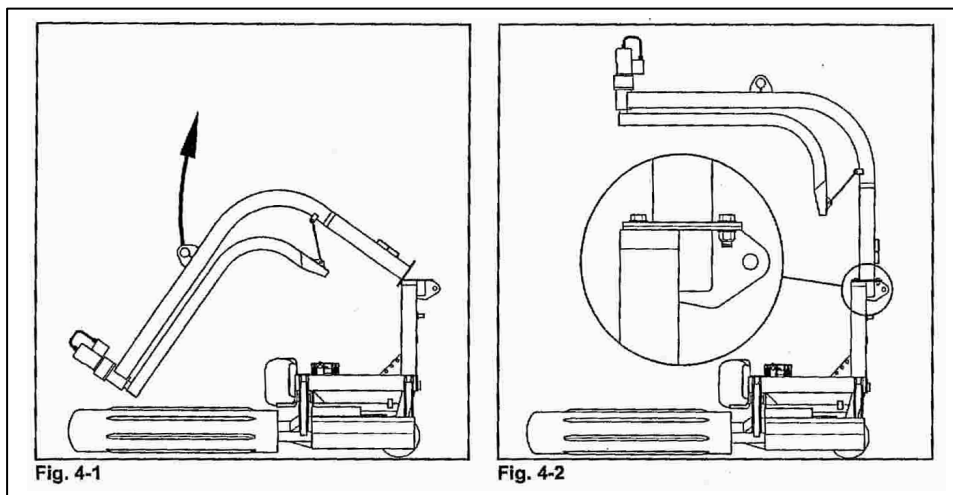

Be careful! There is a danger of being crushed when working implements are fitted and connected. Carry out the fitting procedures slowly and carefully, and use separate and approved lifting equipment to make the work easier. See section 2 on safety regulations and pay attention to the various safety decals displayed on different parts of the bale wrapper.

4.1 HINGED TOWER.

Because of the freighting of the machine, AUTO WRAP 1500 / 1514 is sometimes delivered with the tower hinged down. Before use, the tower must be lifted up and fastened with 5 pcs. 16mm bolts.

Figure 4-1 shows the machine at delivery.

Remove all packing strips and lift up the tower. Use a crane or the front-loader on the tractor and lift in the lifting point at the top of the machine. (See arrow). Then mount the 5 pcs. M16 x 55 bolts with washers and lock nuts.

Securing the davit on TWIN machines is slightly more complicated because of the bracing clamps which have to be fitted on each side of the davit. Fit the lower fixing screws for the clamps (8 screws size 12 x 140).

SCREW IN SECURELY and after several hours' use tighten all the screws once again.

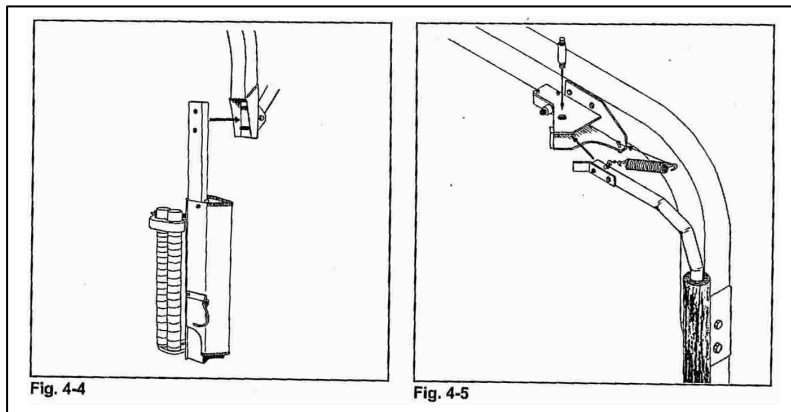

4.2 MOUNTING OF DISPENSERS

The dispensers are attached to the Wrap arm using 2 M12 bolts at a fixed height. The same procedure is followed for fitting the brace on TWIN machines.

4.3 MOUNTING OF EMERGENCY STOP* ARM.

The machine is equipped with an emergency stop*, and the releasing arm has to be mounted. Put the arm into the bracket and mount the hinge bolt. Replace the washers and tighten the locking nuts. (See fig. 4-4).

The return spring is to be fastened between the eye bolt on the arm and the eye bolt on the bracket.

(See chap. 9-1 in the spare parts list for details).

TWIN machines have emergency stop arms on each brace and are fitted in the same way as they are on standard machines.

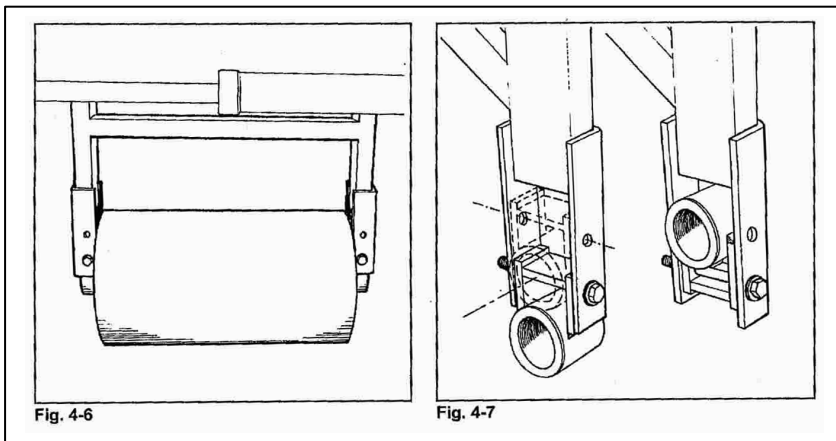

4.4 MOUNTING OF SUPPORT ROLLER.

Lastly, the support roller under the machine has to be mounted. When the machine has been mounted on the tractor, lift it clear of the ground, and secure it from falling down before working underneath the machine. Mount the relief roller with 2 pcs. M12 x 120 bolts, washers and lock nuts. (See fig. 4-6).

The off-loading roller can be fitted at three different heights. On the Auto Wrap 1510 it is fitted at the top position as illustrated on the right in fig. 4-7. (The locating bracket must be turned 180E) On the Auto Wrap 1514 it is fitted at the center position if rectangular bales (for example, 90 x 120cm) are to be wrapped. For bales which are larger than this, it is fitted at the lower position.

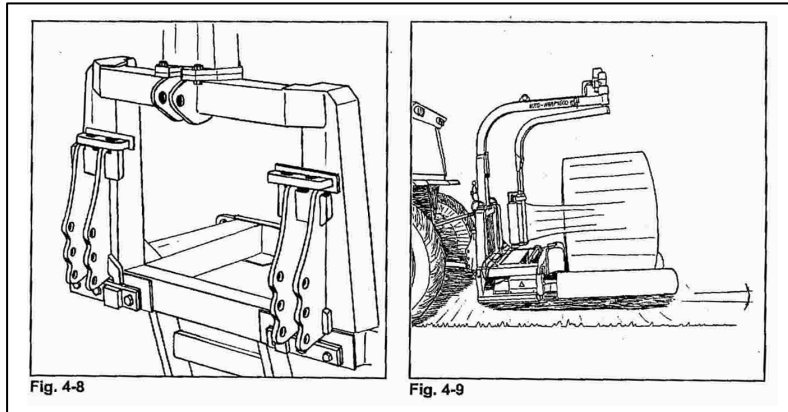

4.5 THREE POINT LINKAGE.

AUTO WRAP 1500 / 1504 /TWIN is intended for rear mounting to the three point linkage, category 2. (Fig. 4-8). For transportation the three point linkage brackets are not always mounted on the machine when it leaves the factory. (See spare parts list chapter 2-1 for more details).

When attached to three point linkage, make sure the machine is level across the tractor. Tight up and lock the lifting arms so there is no sideways movement.

4.6 TOP LINK.

Adjust the top link of the tractor so that the machine is level with the ground. It is recommended to use a hydraulic top link, as this makes it easy to adjust the angle of the machine.

During the wrapping process it is recommended to tilt the machine towards the tractor, as this will prevent the bale from falling off the rollers. (See fig. 4-9).

4.7 FRONT MOUNTING.

As extra equipment the machine can be equipped with attachment brackets for front loader or wheel loader. (See spare parts list chapter 2-2 for what types of brackets there are).

You also need longer hydraulic hoses. (See spare parts list chapter 4-2 for more details).

When front-mounted there must be mounted a large enough counterweight in the three point linkage, this is to secure the tractors stability.

4.8 ELECTRIC CONNECTION.

The electric supply for the machine's control unit and electro-hydraulic components must come **directly from the tractors' 12 volt battery.**

The electric wires from the battery must have an area measurement of min. 2,5 mm². Connection of other contacts on the tractor can cause risk of malfunction, and is not recommended.

**BROWN LEADER GOES TO BATTERY PLUS POLE
BLUE LEADER GOES TO BATTERY MINUS POLE**

4.9 CONTROL UNIT

The control unit consists of the emergency stop button, a communication cable, and a power cable. The control unit should be attached to a suitable place in the tractor cab, using the supplied suction cup.



Fig.: 4-10

The control unit is supplied with: Battery power cable (we recommend direct connection to the tractor's battery), suction cup and control unit mounting bracket. The mounting bracket should be mounted on the back of the controller in such a way that the suction cup is directly behind the push buttons.

IMPORTANT!

When connecting the control unit to the machine, always ensure that the communication cable cannot get damaged by the 3-point linkage or dragging along the ground, by tying slack cable inside the cab.

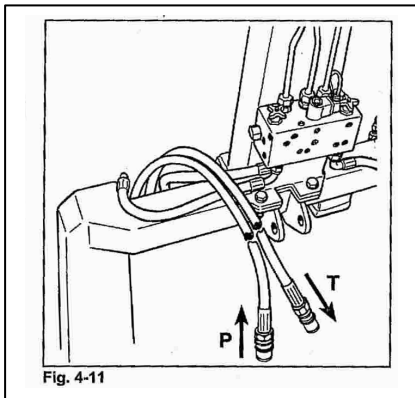

Fig. 4-11

4.9 HYDRAULIC CONNECTION.

The hydraulic hoses between machine and tractor are equipped with 1/2" ISO male quick-couplers. Discharge the oil pressure before you connect the oil hoses. The tractors' hydraulic lever must be lock open when running. To make sure that the bale wrapper works properly, the tractors' oil pressure has to be at least 180bar. The oil flow should be 15 - 25 liters per minute.

The return pressure on the return must be as low as possible, and not exceed 10 bar. This should be measured with a gauge. It is recommended to use one single-acting hydraulic outlet and arrange a free return circuit to the oil tank. If you are unsure of what oil pressure the tractor gives, or what oil pressure the bale wrapper receives, please contact your machinery dealer. Generally all tractors have got some counter-pressure in their hydraulic return systems. Some tractors have more than others.

Hose with red cap shall be connected to pressure, (P), and hose with blue cap to the return. (T). (See fig. 4-11).

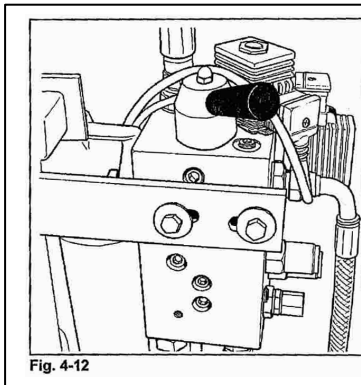

Fig. 4-12

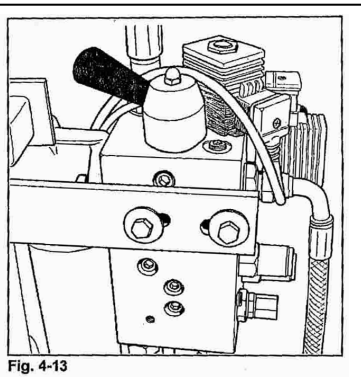
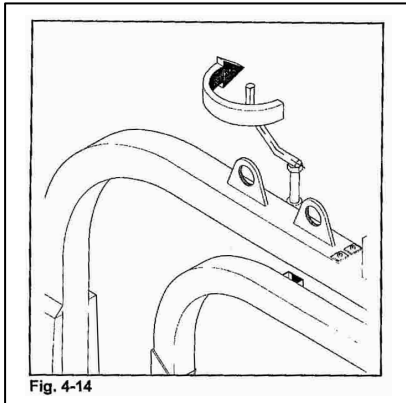

Fig. 4-13

4.10 HYDRAULIC SYSTEM WITH OPEN OR CLOSED CENTER (See also section 14.1.)

The selective control valve (V1) allows you to choose between an open and closed center for the hydraulic system. Most tractors have a hydraulic pump which produces a fixed volume of oil per revolution (open center). The valve must then be in the open position. (See fig. 4-12.) Some other tractors (such as John Deere) have oil pumps with **variable** volume per revolution (closed center). The valve must then be in the closed position. (See fig. 4-13.)



4.11 CHECK LIST.

Before using the machine it is recommended to follow this check list:

1. Make it a habit to discharge the oil-pressure before connection or disconnection of the hydraulic hoses. (Use the tractors hydraulic control lever).
2. Return-oil should be led as directly to the tank as possible. Beware that if the return line pressure is too high, the security valve on the main block will release some oil. (See chapter 14.3).
3. Hose with **BLUE CAP = RETURN OIL.**
4. Hose with **RED CAP = PRESSURE.**
5. Tie up loose hoses so that no squeeze damages may occur.
6. Remove the locking bolt that holds the wrapping arm to the frame during transport. (Fig.4-14 and Fig. 2-7) If necessary unfold and lock the extra wrapping arm on a TWIN machine. Do the same with the cutter beams. (See section 2.10 and figs. 2.7, 2.8, 2.9 and 2.10.)
7. Make sure that the plug-in contact from the control unit is connected to the socket on the machine.
8. Start the tractor and try out the functions. A bale is not required for this test.
9. Check all connections, hoses and couplings. If there is any oil-leakage, it should be rectified immediately.

If any problems should occur, it is most likely that the failure is in the quick-couplers on the tractors pressure and return-connections.

The nipples of these connectors get worn and cause pressure build up which causes extra heat. **Make sure that both the male and the female-couplers opens properly for the oil flow.** Check them carefully. The best thing to do is to exchange the quick-coupling on the return side and arrange a "free return".

Your AUTO WRAP bale wrapper has been tested in practical operation in approx. 2 hours at the factory.

NOTE: The return line is fitted with a non-return valve which prevents oil flowing through the system if the tractors spool valve is pulled in the wrong direction.

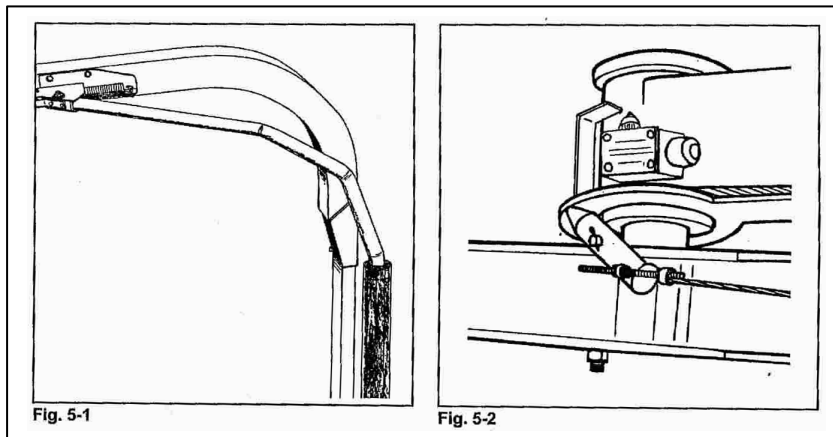

5.0 EMERGENCY STOP.

- 5.1 The machine is equipped with a safety guard on the wrapping arm, and its operation must be tested before using the machine.
- 5.2 The safety guard is designed to stop the wrapping arm injuring operators or objects either when starting up or when wrapping bales.
- 5.3 The emergency stop* is constructed with a "positive" connection, i.e. it has to be in full order before the machine can be started.
- 5.4 This consists of a release guard which is connected by a wire to the lever arm, and this activates a small electrical switch via a sliding contact (14, fig. 5-2).
If the electrical circuit is broken, the hydraulic oil flow is cut off and all functions stop immediately.
An Error signal is indicated on the control box display. (See section 7.1.)
- 5.5 When this function shall be tested, you start the wrapping arm. Hold out an arm or any obstacle. The wrapping arm shall now stop before it hits the arm.
- 5.6 To restart the machine the obstacle must be removed and the safety guard must return to its original position. Reset the controller by pressing and releasing the Red "E-Stop" button on the controller. The wrap cycle can then be resumed by pressing the resume cycle switch. (See further in section 8.0.)

6.0 FITTING ROLL OF FILM

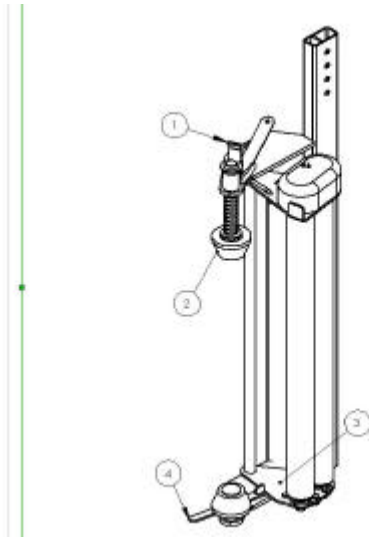

Fig.: 6-1

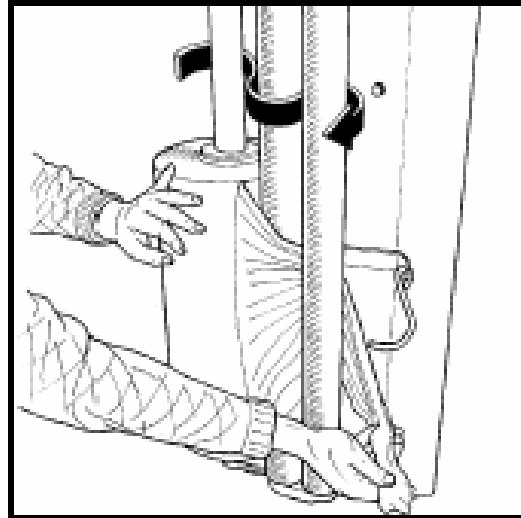

Fig.: 6-2

- 6.1 When loading a plastic roll, first ensure the top cone (2) is pushed up to latched position, then push back the Stretch rollers (3) until held in position by locking catch (4).
- 6.2 Place the Roll on the Bottom Cone and release the top latch (1).
- 6.3 Pull the film between the rollers on the pre-stretcher in the direction of the arrow. (See fig. 5-2) (See also the sticker on the dispenser).
- 6.4 Release the locking catch and allow the rollers to lie against the roll of film. Pull the film from the roll and tie it to the bale.
- 6.5 **HEIGHT ADJUSTMENT OF PRE-STRETCHER / PLASTIC FILM.**

The plastic film should hit the bale in the middle. As the Dispenser is at a fixed height it is necessary to adjust the Roller arm stops. i.e if the bale is too low, adjust the stops so that the rollers close more, thus raising the bale and vice versa. See section 10.3.

If you use 500 mm plastic on a 750 mm dispenser, which is recommended for wrapping smaller square bales, you need to use the "500 mm film adaptor" (see spare parts book).



7.0 CONTROLLER MANUAL

Contents

1. INTRODUCTION

1.1 IMPORTANT SAFETY INFORMATION!

1.2 Main operating Functions and Display

2. OPERATION

2.1 Operation in Automatic mode

2.2 Operation in Manual mode

2.3 Manual options in Automatic mode

2.4 Operations in Manual mode

2.5 The Display Menu

2.6 Selecting a Store Total

2.7 Resetting a Store Total to Zero

2.8 Setting the Number of Wraps

2.9 Film Break Alarm (Optional)

3 OPERATOR SETUP MENU

1. Introduction

The Tanco Autowrap Bale Wrap Controller enables the operator to monitor and control the operation of the bale wrapper at any stage of the wrapping cycle. The controller is designed for models : 1300EH, 1510EH, 1510T, 1514S, and 1514T rotating-arm type wrappers.

There are 2 operating modes – Automatic and Manual. The automatic mode permits 'one-touch wrapping' to ease the workload on the operator. The controller is fully programmable to optimise wrapping performance. Bale counts are automatically logged in any one of 10 selectable memory stores, in addition to a grand total memory store.

1.1 IMPORTANT SAFETY INFORMATION!



- Please read and understand the instructions for using this controller before operating the machine.
- This controller is fitted with a pushbutton type On/Off Emergency Stop switch. Always ensure the controller is switched OFF via this switch before attempting any adjustment or maintenance to the machine.
- Please follow ALL other safety instructions given in the manufacturers' Operator Handbook for this machine.

1.2 Main operating Functions and Display

The principal instrument features and operating functions are shown in figure 1 below.



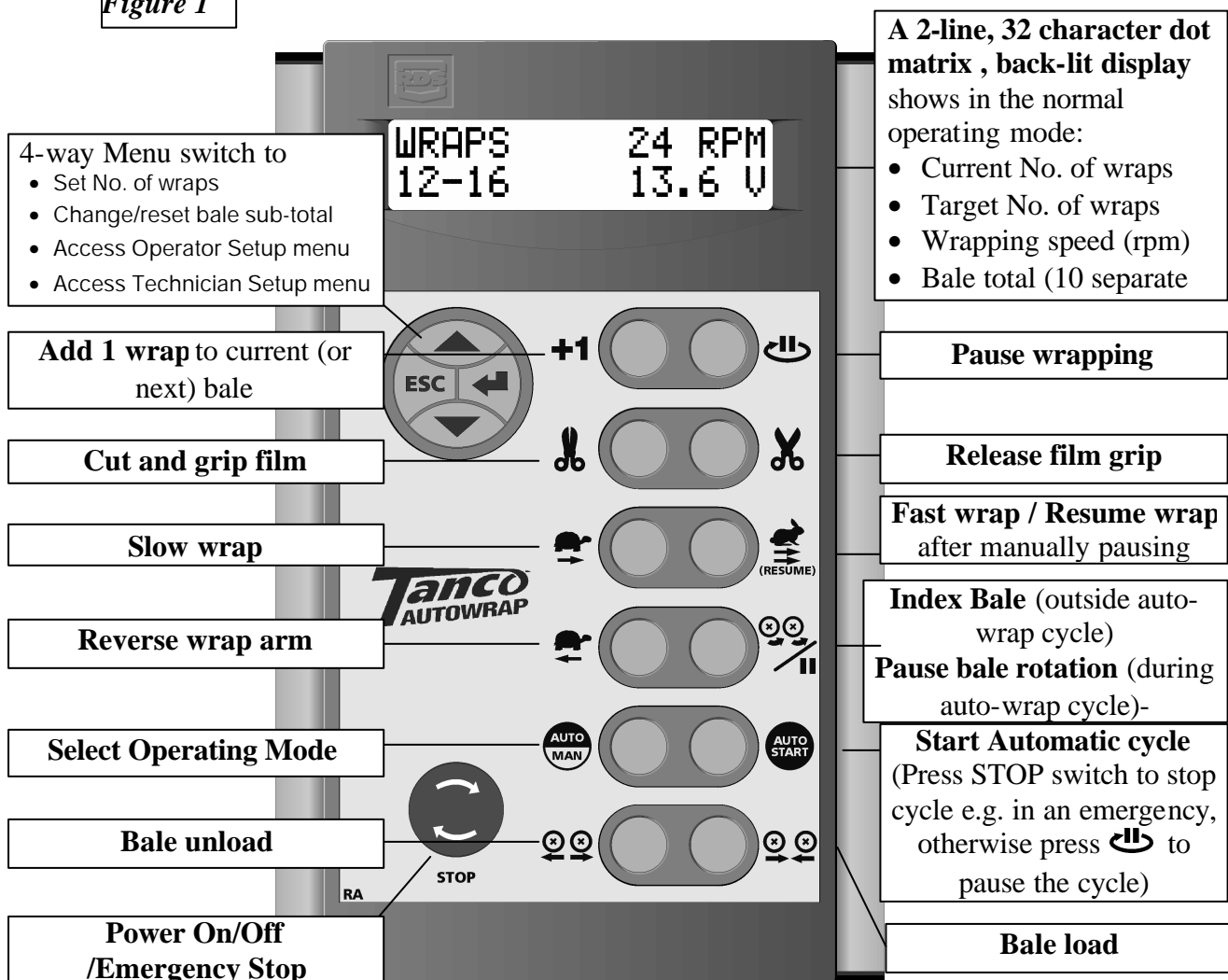

Figure 1



2 Operation



2.1 Operation in Automatic mode

The controller is generally used in automatic mode for 'one touch wrapping'.

1. 'A' on the display indicates that the controller is set in Automatic mode. If not, press  to select.
2. With the rollers in the open position (step 4), bring the machine up to the bale.
2. Press the  switch* to move the rollers to the closed position.
3. Press the  switch to commence the automatic wrapping cycle. The cycle is completed when the target number of wraps has been reached.
4. Press the  switch* to move the rollers to the open position to unload the bale.

* The controller must be configured in the Operator Setup menu (section 3) so that this is a 'one touch' function in automatic mode. Otherwise you must hold the switch for the required duration (as remains the case in manual mode).

2.2 Manually interrupting an automatic wrapping cycle

Press the  switch to bring the wrapper to a controlled stop. Pressing the  switch will continue the auto-wrap cycle from where it stopped.



For safety reasons, if it is necessary to work on the machine (e.g. in the event of a film break or the film running out), then it is strongly recommended that you then switch the controller off via the red stop button and disengage the machine power source. Pressing the  switch after switching the controller back on will resume the auto-wrap cycle from where it stopped.

Unless it is an emergency situation, do not bring the machine to a stop by pressing the red stop button as this will impose unnecessary strain on the machine.

2.3 Manual options in Automatic mode

With the controller in automatic mode, the following manual functions are possible.



SLOW WRAP (not during the wrapping sequence). Press  to resume the normal fast wrap.



REVERSE WRAP ARM (only enabled outside of the wrapping sequence). Press this button to nudge the wrap arm backwards to the desired position.



PAUSE BALE ROTATION (function active during auto-wrap cycle). Hold this button to add more film to a particular part of the bale. Release the button when sufficient additional film has been applied.



BALE INDEXING (function active outside auto-wrap cycle). Press and hold this button to index the bale. Release the button when the bale is at the desired position.

NOTE: The controller can be configured from the 'Operator Setup' menu (section 3) so that this is a 'one-touch' function and the bale will then index for the preset period (e.g. to allow a ¼ turn).



ADD 1 WRAP Each time you press this button an additional wrap will be put on the current bale if the wrapping sequence is in progress, or onto the next bale if the automatic cycle has not yet been started. You can add as many wraps as required.

2.4 Operation in Manual mode

'M' on the display indicates that the controller is set in manual mode. If not, press  to select.

In manual mode you have total control of every stage of the wrapping cycle.

The software logic determines which manual functions can be activated at any point in the wrapping cycle. Should the operator incorrectly select a function at a certain stage during the wrapping cycle, then that operation will not be performed.



2.5 The Display Menu

The Display menu is divided into 3 sections. At the top level are the settings used during the daily work with the machine – i.e. Store totals and No. of Wraps.

The Operator Setup' section enables the operator to perform adjustments to the machine operation – e.g. time duration and time delay settings during the automatic cycle.

The 'Technician Setup' menu is not normally accessible to the operator without a PIN access code. 'Technician Setup' is not covered by this manual.

Use the 4-way switch to navigate the menu. Each menu screen indicates which keys to press to make the settings. The instrument will default back to the main operating display after 30 seconds if no other key is pressed

Here is a summary of the display menu;

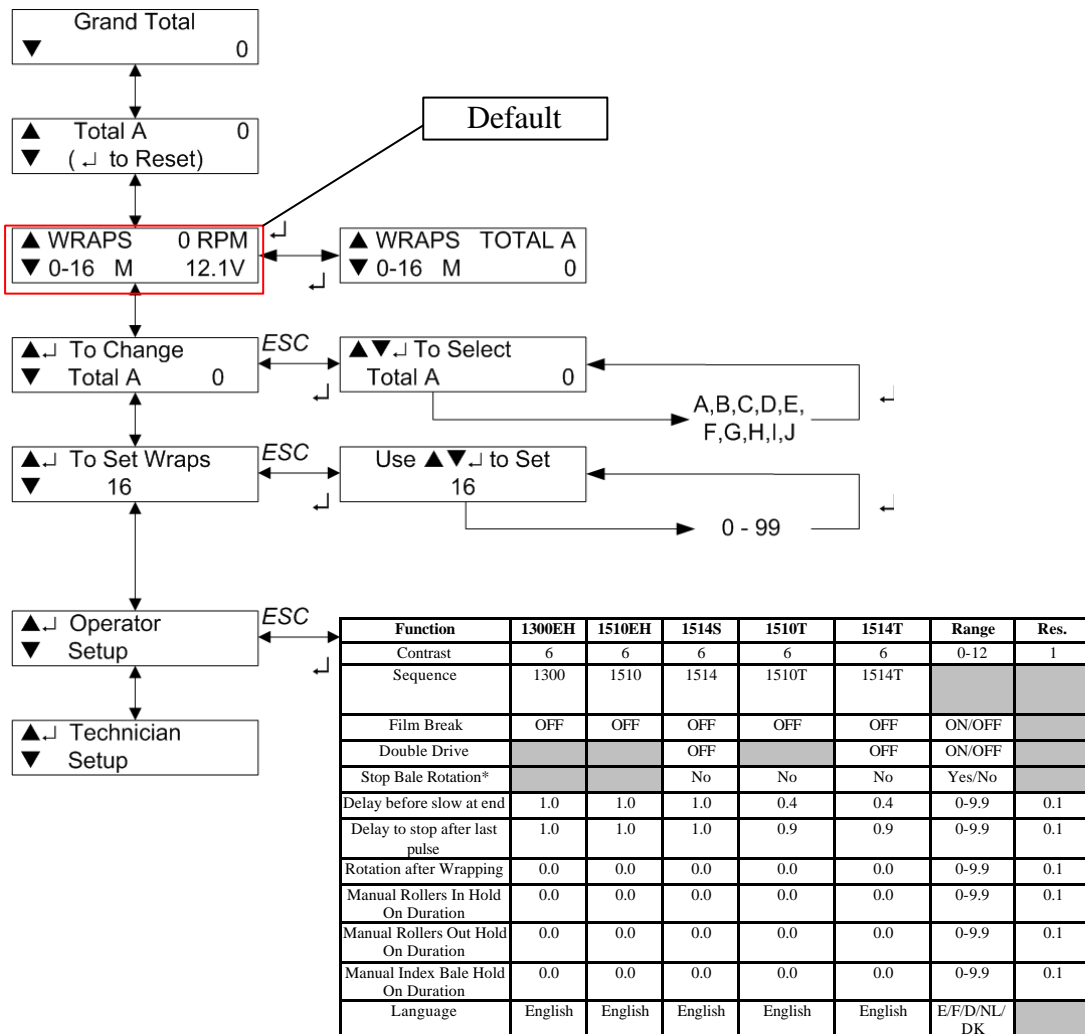

NOTE: There are additional sequences selectable in the Operator Setup menu but not shown in the table. These sequences are for wrapper models to which this manual does not apply. Please refer to section 3 for further explanation of the Operator Setup functions given in the table above.



2.6 Selecting a Store Total

There are 10 individual memory registers labelled 'Store A' to 'Store J' for bale totals. Each time a bale cycle is completed, the currently selected store total and the grand total increments by 1.

The currently selected store is displayed on one of the two screens selectable in the normal operating mode.

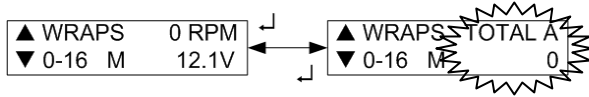

The default setting is Store A. To select a particular store, navigate the display menu using the 4-way switch.

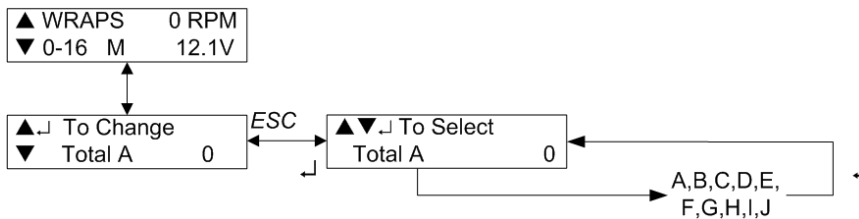

Press the up/down arrow keys to select the store, then press the ENTER key to confirm the selection.

2.7 Resetting a Store Total to Zero

Stores A to J can be individually reset to zero at any time. The Grand Total store cannot be reset. First select the store to be zeroed, then navigate the display menu as shown below.

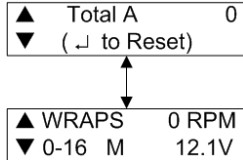

Press the ENTER key to reset.

2.8 Setting the Number of Wraps

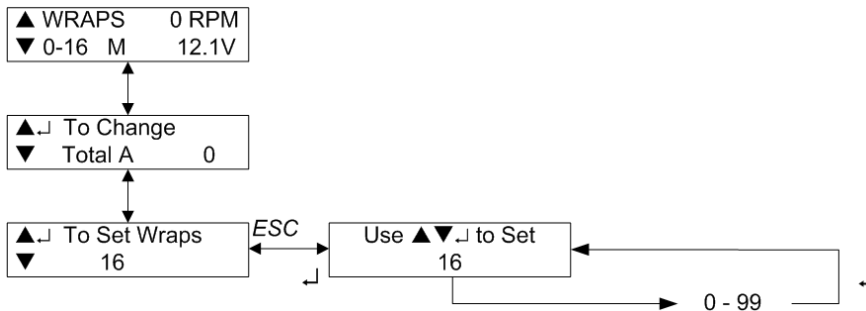

The default number of wraps is 16. You can set the target number from 0 to 99 by navigating the display menu as shown below.





3 Operator Setup Menu

The default settings for the machine are developed by Tanco for optimal operation of the machine. However, the operator can change certain parameters in the 'Operator Setup' menu to take account of operational conditions.

Parameter	Default	Application	Description
'Film Break'	OFF	N/A	N/A
'Double Drive'	OFF	1514S, 1514T only	Set 'ON' to enable both pairs of rollers to be driven.
'Stop Bale Rotation'	No	1510S, 1514S, 1514T only	Set 'Yes' to delay bale rotation for a preset time period after the wrap cycle begins. This enables additional wraps of film to be applied for extra strength e.g. when wrapping two bales together.
'Delay to Slow'	1.0s 0.4s	1300EH, 1510S, 1514 1510T, 1514T	Determines the point of speed reduction at the end of the wrapping cycle
'Delay to Stop'	1.0s 0.9s	1300EH, 1510S, 1514 1510T, 1514T	Set to adjust the Stop position of the wrap arm
'Rotation After'	0.0s	All	Set time period to rotate the bale to an optimal orientation for unloading
'IN Hold Time'	0.0s	All	Sets the latch-on time period for closing the bale rollers. Effectively allows 'one touch' operation instead of having to hold the  switch in Automatic mode. Does not apply when in Manual mode
'OUT Hold Time'	0.0s	All	Sets the latch-on time period for opening the bale rollers. Effectively allows 'one touch' operation instead of having to hold the  switch in Automatic mode. Does not apply when in Manual mode
'Bale Hold ON'	0.0s	All	Sets the latch on time period for indexing a bale. Effectively allows 'one touch' operation instead of having to hold the  switch in Automatic mode (e.g. to index a ¼ turn).
Language	English	All	Sets the language for the display prompts.

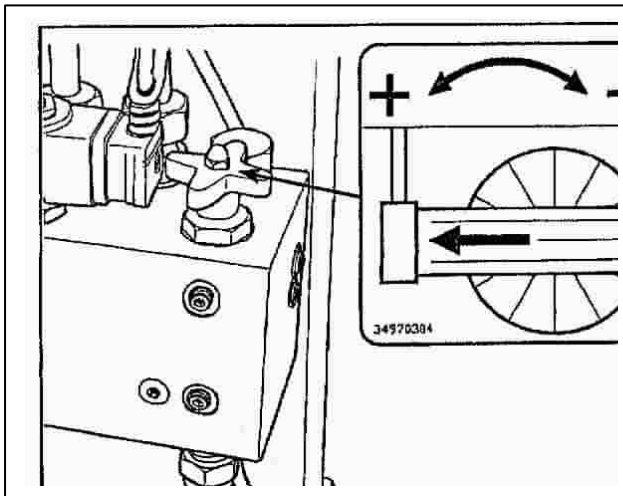

8.0 SPEED-SETTING OF THE WRAPPING ARM.

8.1 Start the tractor, let it run at approx. 1000 revolutions per min. lift the machine clear off the ground.

The oil flow to the Wrap arm and Rollers is adjusted with the use of two control valves which are placed on the valve block situated behind the machines "tower". [see fig. 8-1]

8.2 The control valve on the right-hand side, is for adjustment of the wrapping arm speed. (See fig. 8-1).

8.3 Adjust the wrapping arm speed to approx. 22 revolutions per minute. (Just below

three seconds per revolution.) The adjustment is carried out by turning the wheel on the control valve. Turning

clockwise REDUCES the speed and turning **counterclockwise INCREASES** the speed.

It is recommended not to wrap with higher speed than 22 revolutions per minute, because then the plastic film will "catch" more air, and this air do not reach to evacuate from the bale. The result is bad fodder.

NB! Max. allowed wrapping arm speed is 27 revolutions per minute.

REMEMBER!

Increased speed of tractor engine do not increase the wrapping speed, it only increases the oil flow into the system and by that also the temperature in the hydraulic system.

9.0 ADJUSTING THE OVERLAP.

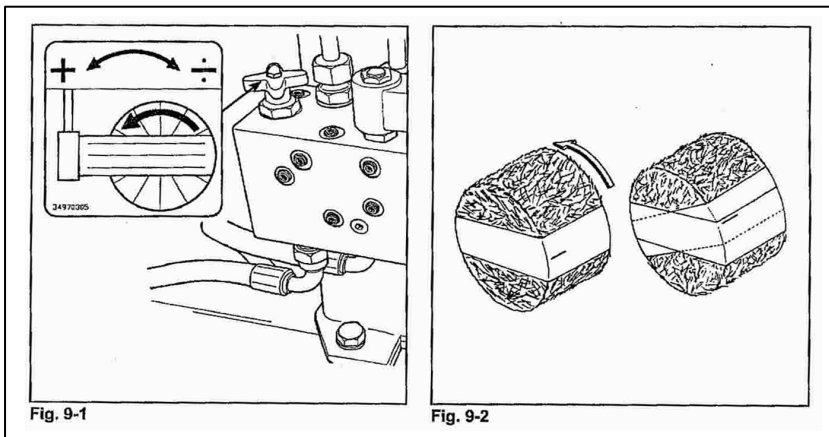

9.1 WRAPPING ARM SPEED.

Load a bale on to the machine. To be able to adjust correct overlap, you have to leave the tractor cab while wrapping. Check that the wrapping arm has a speed of approx. 22 revolutions per minute. If not, adjust this by turning the control valve for wrapping arm speed. (See chapter 8.3). When the wrapping arm speed is OK, you can set the overlap.

9.2 OVERLAPPING.

Use a black marker to mark a line on the middle of the film wrapped on the bale. Adjust the control valve for roller speed, (see fig. 9-1), so that the marker line is just covered. Approx. 52-53% is the ideal overlap. (See fig. 9-2).

This adjustment can be kept as long as you wrap bales with approx. same diameter. When changing bale size, control the overlap.

10.0 OPERATION INSTRUCTION.

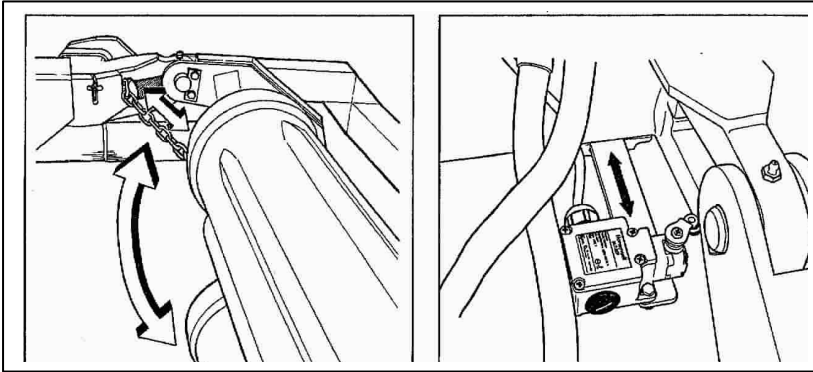

We shall now go through a complete wrapping process, from loading to storage place, and explain the practical use of Auto Wrap 1510 / 1514 / TWIN.

10.1 LOADING

Find a bale you wish to wrap. Increase the opening between the bearer-rollers as much as possible.

A limiting chain has been fitted to the each set of rollers on the 1514 machines to make them stand vertically above each other and lift up a small square bale more easily. This may need to be adjusted to Rollers are vertical. (See fig 10-1.)

CLAMP VALVE. (V23)

If the machine has difficulty loading the bale, or if the rollers spin against the bale during loading, an adjustment of the clamp valve may be necessary. (V23, fig. 14-7.)

The valve is adjusted so that the width cylinders retract more easily during loading. Loosen the lock nuts and adjust the valve. Turning clockwise increases the clamping pressure.

MAX. CLAMPING PRESSURE SWITCH

On the left-hand bearer-arm a switch is fitted which engages V20 when the rollers have gone far enough in under the bale. This will vary according to the size of the bale which is being wrapped, so this switch must be adjusted to the desired position.

When this switch is tripped, the rollers stop rotating and only the width cylinder is connected. (See also section 10-2.)

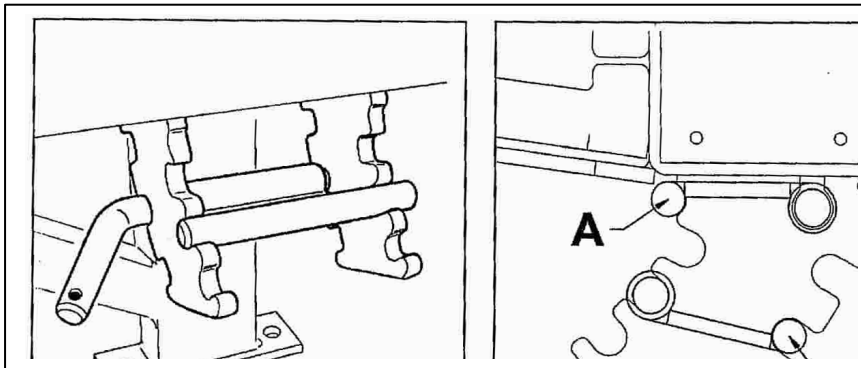

10.2 HEIGHT ADJUSTMENT OF DISPENSERS.

The Film Dispenser are fitted in a fixed position on the wrap arm. It is fastened with two bolts. To ensure the plastic film is always hitting the middle of the bale, you must adjust the roller arm stops (see section 10.3). The film dispenser is designed for use with 750 mm film. If you use 500 mm film, special film adaptors are required. (See spare parts book).

10.3 ROLLER-ARMS STOPS

To ensure the plastic film is always hitting the middle of the bale, you must adjust the roller arm stops. This is done by moving the stop pins under the main tilt ram.

They can be placed in four different positions, (B), as well as removed, (A), as shown in figs. 10-3 and 10-4. Place the stop pins in the required position, fit the bolts and secure with the split pin. (The bearer-arms must be fitted against the main tilt ram/stop pins before wrapping is started so that the bale does not rock from side to side.)

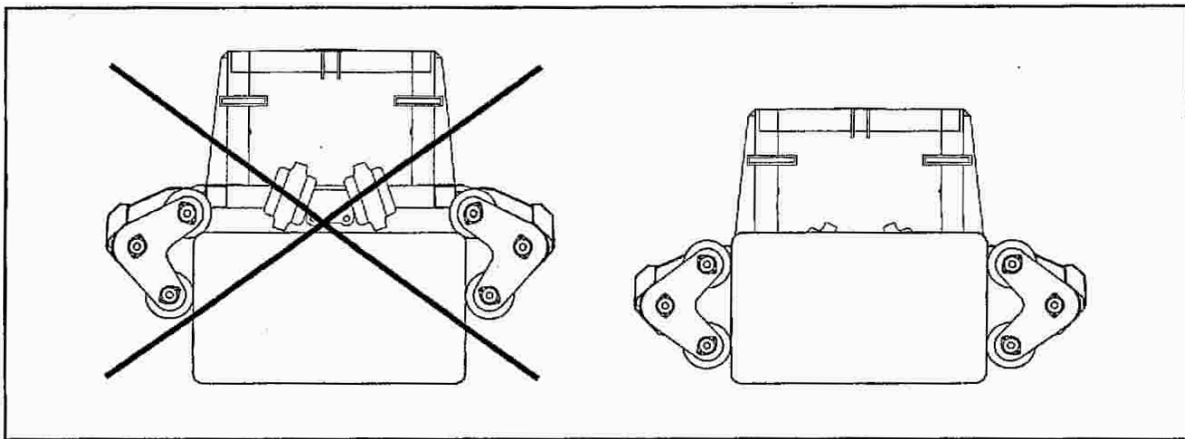

Fig.10-5

10.4 WRAPPING SQUARE BALES. (Auto Wrap 1514 / TWIN).

- a) When loading small square bales it is important to lower the rollers as close to the ground as possible. This to make all four rollers to get a grip on the side of the bale. If two of the rollers come over the bale, the machine will not be able to load it. (See fig. 10-5). If necessary, adjust the position of the rollers by means of the limiting chains. (See section 10.1.)
- b) Minimum recommended bale size is 60 x 90 cm, (2' x 3'). If you wish, you can place two bales upon each other, and wrap them together as a bale of 120 x 90 cm, (3' x 4'). (Max. bale size is 120 x 120 cm. (4' x 4')).
- c) When wrapping rectangular bales, (e.g. 70 x 120 cm), the bale will rotate with uneven speed.
To get a smoother wrapping, or if you want more film on the long sides of the bale, it is recommended to mount a hydraulic valve that stops the rotation of the bale while the wrapping arm continues to go. (See V14, chap. 14.3).
- d) Sometimes it can be necessary to move the width between the rollers while wrapping. This is most in common when wrapping bad shaped and loosely packed bales. If the machine has problems rotating the bale, you can move the rollers in or out with the **ROLLER OUT (7)** or **ROLLER IN (6)** with the control box while wrapping.

10.5 START.

Remember that the plastic film end has to be held in the cut and start unit before starting the Wrapping cycle. When the plastic film end is held, push **START (8)**, and the wrapping arm now moves at ½ speed for approx. one half revolution before it automatically switches to full speed. This is to avoid damage of the film when starting. When the wrapping arm has done a couple of revolutions, the cutter-arm automatically releases the film end. (See also chapter 7-11).

10.6 OVERLAP.

Control that the overlap is correct. If not, see chapter 9.0.

10.7 HOW MANY LAYERS OF PLASTIC FILM?

When the bale is completely covered with film, read the counter that displays the number of revolutions done by the wrapping arm. This number has to be multiplied by 2 or 3, depending on how many layers of film you want to have.

- **4 layers - multiply by 2.**
- **6 layers - multiply by 3.**

As long as you wrap bales with the same diameter, you can stop at the same number every time.



10.8 STOP.

On the last revolution, the controller automatically slows, the cutter opens, and it stops at the right place for next wrapping cycle. Then the cutter closes automatically, and the film is held tight in the U-formed slot and perforated. The bale is now completely wrapped and ready for stacking.

EXTRA EQUIPMENT (Standard on 1514's)

If the machine is equipped with **Rotation after wrapping**, the bale will be rotated till it is in the right position for off loading, by pushing and holding the Rotate rollers button-button.

10.9 When the wrapping sequence is ended, Off Load the bale by pressing the Rollers out button.

10.10 After a certain delay the controller is reset and the bale counter is incremented.

10.11 STORAGE PLACE.

At the storage place the bales should be placed systematically. Start at the right-hand side, and stack to the left. Lower the machine until the support roller rests on the ground. Push control 7, **ROLLERS OUT**, and the bale will rest on the ground. Drive the tractor carefully away from the bale. Try to avoid touching the bale with the rollers. The plastic film will now tear off by the perforation at the cutter. Place the next bale to the left of the first one so that the loose film end on the last ball will be locked. Then you do not have to leave the tractor cab to fasten the loose film end. To be sure we recommend that you check that the film ends are securely fastened, and eventually fasten them a little bit better when you have stacked the bales.

If the machine is front mounted, the bales can be staked upon each other. (See more in chapter 3.0).

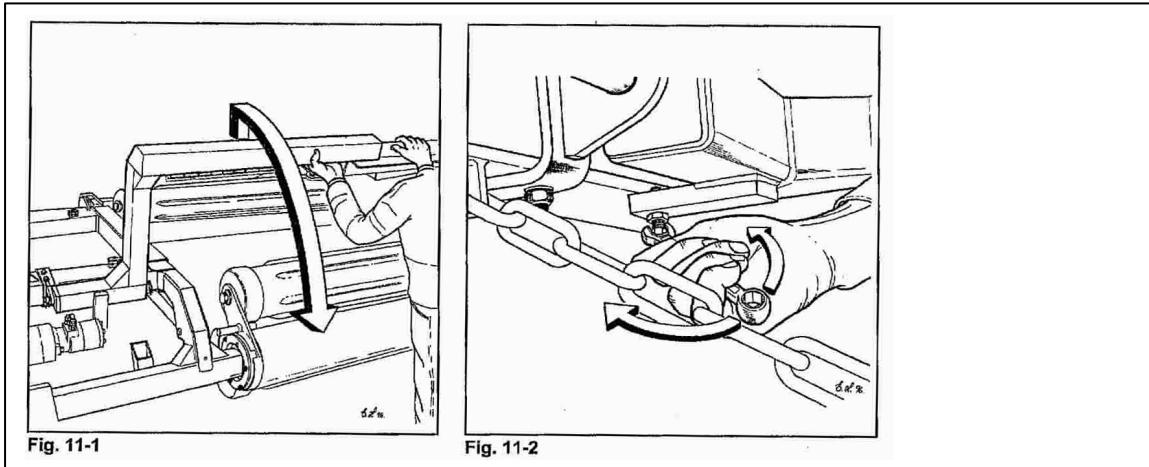

Fig. 11-1

Fig. 11-2

11.0 SPECIAL OPERATING INSTRUCTIONS FOR THE TWIN MACHINES

The Auto Wrap 1510/1514 can, as described earlier, also be supplied with a double set of wrapping arms, film stretchers and cutters. This significantly increases the machine's capacity. This machine is essentially the same as a standard machine, apart from having tower stabilizers fitted and an extra valve block for the wrapping arm motor which reverses the wrapping arm after the wrapping sequence is completed.

It also has two cutters which are fitted on a hinged cutter beam on each side of the machine.

11.1 PREPARATION

Before the machine can be used, the wrapping arm must be "folded out" and the cutter beams placed in their operating positions. See fig 2-8 and fig 11-1 for more detailed descriptions.

ADJUSTING THE CUTTER ARM.

The height of the cutters can be adjusted if, for example, the pinching arm does not hold the film properly. Loosen the lock nuts and adjust the cutter arm to the required height. Tighten the lock nut again. (See fig. 11-12.)

11.2 WRAPPING

Before the TWIN machines load up the bale, the wrapping arm must be positioned perpendicular to the machine (i.e. the stop position). Position the wrap arm correctly in Manual mode pressing and holding the wrap slow button. Then fix both the film ends securely in the cutters. (See sections 6.4 and 6.5.)

When adjusting the overlap, (chapter 9.0), the roller speed is set to approx. 52-53% overlap between the two pre-stretchers. This means that the rollers must rotate twice as fast as on a standard machine.

When the wrapping sequence is completed and the wrapping arm has stopped, the wrapping arm will not be parallel with the bearer rollers. As soon as the cutters have closed, the wrapping arm will automatically reverse back to the start position which is at right angles to the Tower.

When the wrapping sequence is over the wrapping arm will be positioning a bit diagonal to the rollers. When the bale is unloaded by pushing **ROLLERS OUT**, the wrapping arm will automatically return to an 90° angle to the tower.

NB ! AUTO WRAP 1510 / 1514 TWIN is supplied for use with 750 mm pre-stretchers. However for best result with smaller square bales use 500 mm film and supplied film adaptors. IMPORTANT! Before the machine is transported on public roads the wrapping arms and cutters must be fixed in the transport-position.

12.0 PERIODIC MAINTENANCE.

12.1 BEARINGS.

All ball-bearings are packed with grease, and do not need any more maintenance.

12.2 DISPENSERS.

If the machine is in daily use, the gears on the pre-stretchers (under the plastic cover) should also be greased once a week or as required.

12.3 CUTTER / FILM HOLDER.

The cutter / film holder is pre-adjusted from the factory and does not need further adjustments. If replacing parts it is necessary to adjust it. The springs for the U-shaped slot shall be adjusted so that they are almost completely squeezed together when the cutter-arm is all down. Adjust the position of the casting at the base of the cylinder until the springs are almost completely compressed.

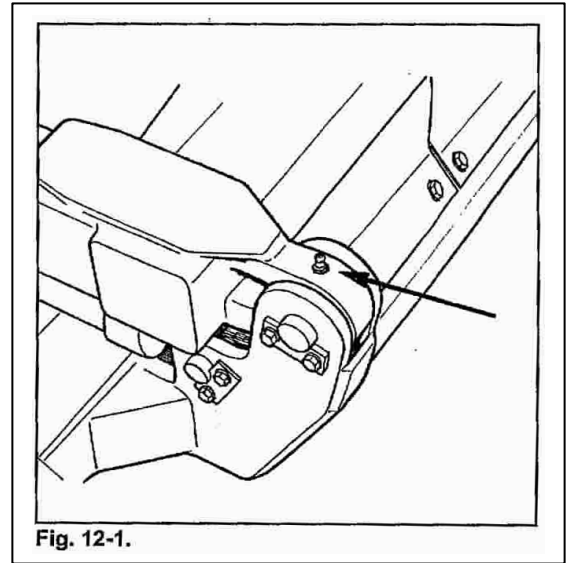

Fig. 12-1.

12.4 PIVOT BEARINGS.

The link bearings between the main frame and roller arms must be greased once a week or, as required. (Fig. 12-1).

12.5 GEAR OIL.

The oil in the gears of the wrapping motor must be changed after the first 100 hours of operation, and then every 2,000 hours or at least once a year. Fill up with new oil to sight glass on side, the quantity being about 1.25L .

Use EP gear oil in the viscosity group VG 150 (ISO 3448) or similar. See the table of approved oils.

TYPE OF OIL	° C / +40° C IV 95 min. (VG 150, ISO 3448)
AGIP	Blasia 150
ARAL	Degol BG 150
BP MACH	GR XP 150
CASTROL	Alpha SP 150
CHEVRON	Non leaded gear compound 150
ELF	Reductelf SP 150
ESSO	Spartan EP 150
I.P.	Mellana 150
MOBIL	Mobilgear 629
SHELL	Omala oil 150
TOTAL	Carter EP 150

12.6 OIL FILTER.

The oil filter must be changed once a year.

12.7 HYDRAULIC CYLINDERS.

Make sure that all hydraulic cylinders are closed when storing the machine.

12.8 QUICK COUPLERS.

Be painstaking about keeping the quick couplers clean and apply the dust caps after use.

12.9 CHAINS/CHAIN TIGHTENERS

After some hours' use the chains on the roller arms which drive the rollers (all 1510/1514/TWIN machines) and similarly the chains at the outer end of the rollers on the square-bale units must be tightened. (1514/1514 TWIN).



12.10 SQUARE-BALE UNIT (AUTO WRAP 1514/1514 TWIN.)

After a period of wrapping, grass will collect around the flanged bearings on the square-bale unit. (Position 16, section 6-5 in the spare parts list.) When this becomes wet, acids can form in the grass which can damage the bearings. This grass must therefore be removed at regular intervals.

12.11 SCREWED FITTINGS

Make a general check of all screwed fittings and tighten where necessary.

Pay attention if removing the wrapping arm as this is fitted on a conical journal and can therefore fall off as soon as the fixing screw is removed from the end of the journey. Always secure the wrapping arm with a strap or something similar to prevent it falling off, BEFORE THE FIXING SCREW IS LOOSENED.

12.12 CLEANING.

The machine should be cleaned and oiled regularly and at the end of the wrapping season.

NOTE !

When using high pressure washing apparatus, care must be taken with the electrical installation.

Also make sure that water is not sprayed directly into the bearings, etc..

Keep the control box protected from rain and water. If necessary use compressed air to dry electrical components.

12.13 STORAGE.

The machine should be parked on a dry place during the closed season.



13.0 ELECTRIC CIRCUIT.

13.1 ELECTRIC SYSTEM.

The electric system consists of a control unit with power supply line, control cable, (24-lead), with plug at control unit side, and distributing lines to the different magnet valves and switches on the machine. (See fig. 13-1).

The electric cables to the valves and switches are numbered from 1 to 15, and extend to the listed appliances below.

1	C & S Open
2	C & S Close
3	Rollers in
4	Rollers out
5	Wrapping arm half speed.
6	Wrapping arm full speed.
7	Master valve.
8	The closed center valve
9a	Rotation sensor
9b	Emergency stop switch.
10	Max. Squeeze pressure switch.
11	Max. Squeeze valve.
12	Rollers Stop
13	Double Drive
14	Reversing Valve
15	Rotate After Wrap



13.2 SUPPLY OF EL-POWER.

The electric circuit must only be connected to 12 volt DC. Connect directly to the tractor battery, to avoid any loss of power. The fuse on the plus-leader must not be more than 15 A. See chap. 4.8 and 4.11.7 about connection and setting up of the machine.

13.3 DESCRIPTION OF THE SYSTEM.

All functions on the machine are operated from the control unit. It is a microprocessor operated, programmable unit that controls the whole wrapping process. When e.g. **START (8)** is pushed, the wrapping arm motor starts at ½ speed. After a preprogrammed time it switches over to full speed. After approx. two revolutions it releases the film end, and switches over to ½ speed again before it stops when number of programmed revolutions is obtained. (See also chapter 7.11). The signals from the control unit are all the time sent to the magnet valves that shall be activated. The exit clips in the control unit are numbered from 1-14.

13.4 POWER DISTRIBUTION. (See fig. 13-1)

When the machine is operating the following valves should all receive electrical current at the same time:

1. "OPEN CUTTER":.....	Current to nos. 1, 7 and 8
2. "CLOSE CUTTER":.....	Current to nos. 2, 7 and 8
3. "ROLL INN":.....	Current to nos. 3, 7 and 8 (+11)
4. "ROLL OUT":.....	Current to nos. 4, 7, 8 and 11
5. Wrapping arm half speed:.....	Current to nos. 5, 7 and 8
6. Wrapping arm full speed:.....	Current to nos. 5, 6, 7 and 8
7. Cutter releases film:.....	Current to nos. 1, 5, 6, 7 and 8
8. Rotation stop (extra equipment):.....	Current to nos. 12, 7 and
9. Double operation (extra equipment):.....	Current to nos. 13, 7 and 8
10. Reversing (TWIN):.....	Current to nos. 14, 5, 7 and 8
11. Rotation after wrapping completed (extra equipment) .	Current to nos. 15, 7 and 8

14.0 HYDRAULICS.

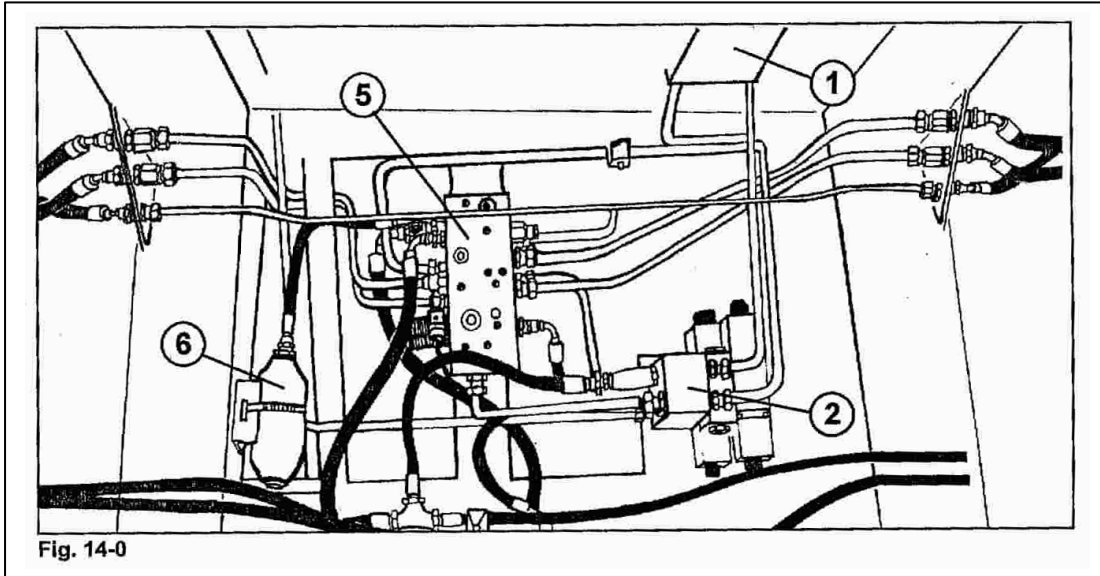

Fig. 14-0

1. Filter block.
2. Control block.
3. Adjusting block. (On the back of the "tower").
4. Wrapping arm block. (On the top of the machine.)
5. Assembly block.
6. Accumulator.

The **AUTO WRAP 1510 / 1514 / TWIN machines** are driven by the tractor's hydraulic system. The machine's hydraulic installation is easy to change from an open center to a closed center hydraulic system. (See section 4.10).

The machine's hydraulics consist of a number of different blocks, and all the valves have a "V" number. They are numbered in a logical sequence from the inlet and then onwards through the whole machine. The valve blocks are marked with every individual valve number, as is the hydraulics diagram.

During the wrapping sequence all three hydraulic motors on the machine are connected in series, i.e. the oil goes first to the wrapping arm motor, and then to each of the roller motors and then back to the tank.

Disconnecting the roller motors is done by means of a hydraulic connection on each of the roller motors. When **ROLLER WIDTH "OUT"(7)** is pressed, the oil travels simultaneously to the releasing cylinders.

The accumulator is also shown in fig. 14-0. This absorbs any pressure surge during load and also ensures that the distance between the bearer arms can increase a little when the rollers go "round the corner" on square bales during loading.

The functions of each particular valve will now be discussed and explained. Refer to the hydraulics diagram in section 18.0 for further clarification.

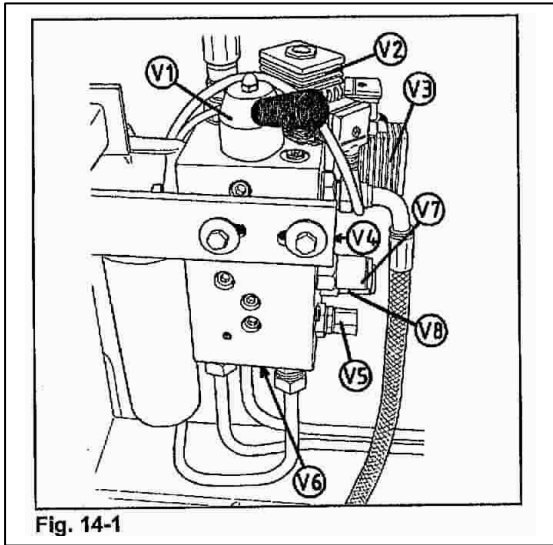

Fig. 14-1

14.1 FILTER BLOCK

This block contains the oil filter, the selector valve for open or closed center, the circulation valve, safety valves and volume-regulating valve.

V1 Selector valve for open/closed center Open center hydraulics

Most tractors have an oil pump which produces a fixed volume per revolution. For these tractors the selector valve must be in the open position. (See section 4.10.) If no other function is activated, the oil flows from the tractor, through the oil filter, the selector valve the circulation valve and back to the tractor.

As soon as a function button is pressed on the control box, the circulation valve, V3, will close the oil circuit and at the same time open the valve for the selected function.

Closed center hydraulics

For tractors with variable oil pumps, for example John Deere, the **selector valve** must be in the closed position. (See section 4.10.)

With this setting the oil can only enter the control block when one of the functions has been selected.

- V2 Closed center valve** (CP 500-3.) (Electric cable number 8.)
Electric valve. This is closed when no function is selected, and opens whatever function has been selected. It releases oil into the control block, and simultaneously opens the LC valve for the particular function. (When the master valve (V1) is in the open position, it has no function.)
- V3 Master valve** (CP 500-4.) (Electric cable number 7.)
Electric valve. When the machine is running idly, this valve remains open and the oil circulates constantly from and to the tractor. As soon as one of the control box functions is selected, this valve will close and simultaneously open the LC valve for the particular function. (When the selector valve (V1) is in the closed position, it has no function.)
- V4 Check valve** (VRC 6.)
This prevents oil from flowing to the master valve in closed center hydraulics.
- V5 Regulator for V6** (CP 610-2.)
Used to adjust the volume of oil that flows into the volume-control valve, which in turn regulates the amount of oil that flows into the control block. At the factory this is set to 35 liters /minute.
This must not be adjusted to a higher figure.
- V6 Volume-control valve** (CP 311-4.)
Limits the volume of oil that flows into the control block. Excess oil volume is sent back to the tractor. This is designed to handle an oil volume of up to 60 liters/minute.
- V7 Emergency overflow valve** (CP 200-3.)
Safety valve on the return side. If the return hose should become blocked, this will open and release oil into the outside. The purpose of this valve is to stop the pressure becoming too high in the drainage connection on the wrapping arm motor. This is set to 120 bar.
- V8 Safety valve** (CP 200-3.)
This prevents the oil pressure from becoming too high in the control block. If the preset pressure level is exceeded, this valve opens and the oil is sent to the return hose. It is set at 180 bar.

14.2 CONTROL BLOCK

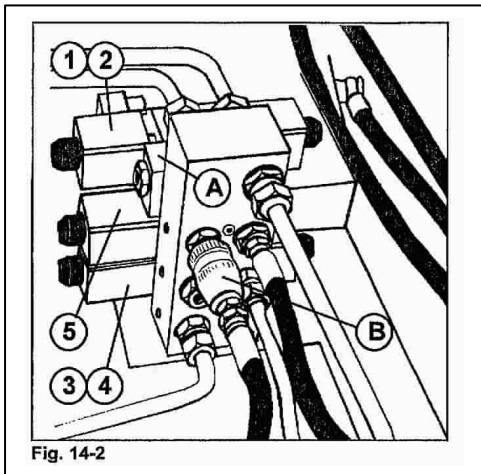

The control block contains the five LC valves that control the main functions of the machine. They do not have V numbers, but have the same number as the electric cables to which they are connected.

(See the diagram of connections, fig. 13.1.)

1. Cutter "open".
2. Cutter "close".
3. Roller width "in".
4. Roller width "out".
5. Start roller and wrapping arm.

The cut and Start unit

To prevent the pressure on the cut and start reducing so that it does not hold the plastic film for sufficient time, there is a double pilot-controlled check valve (**A, fig. 14-2**) below the solenoid valves for the cut and start.

Below the check valve on the block itself there is another check valve which stops any pressure surge in the return hose opening the pilot-controlled check valve.

An adjustable throttle valve (**B, fig. 14-2**) is fitted on the plus side of the cutter cylinder on TWIN machines. This is used to adjust the speed of the cutter when it opens.

(On standard machines there is also a throttle, but this is fixed and is fitted inside the valve block.)

14.3 ADJUSTING BLOCK

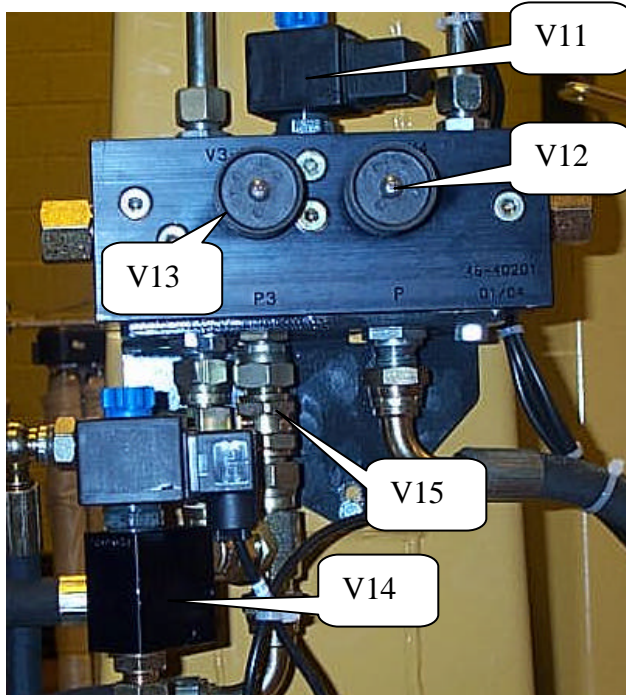

This contains the adjusting valves for roller speed and wrapping arm speed, together with the two-stage start valve.

- V11 Two-speed valve** (Electric cable no. 6.)
The speed is divided into two stages in order to make the wrapping arm start and stop smoothly.
(This happens automatically.)
When the wrapping sequence starts, the valve is closed. This makes the oil from the wrapping arm motor go through a nozzle that limits the speed. After about half a revolution the two-stage valve opens and the oil flows outside this nozzle. This makes the wrapping arm turn at full speed. The same thing happens when the arm is stopped, but in reverse order.
- V12 Volume-controlling valve for the wrapping arm**
This regulates the oil volume and thereby the speed of the wrapping arm motor. This is controlled by V12. Excess oil is directed onwards to V9.
- V13 Volume-controlling valve for the rollers**
This regulates the oil volume and thereby the speed of the roller motor. This is controlled by V13. Excess oil is directed back to the tractor.
- V14 Rotation stop valve (Additional equipment, standard on 1514)** (Electric cable no. 12.)
If there is a requirement to be able to stop the rotation of the rollers while the wrapping arm continues to turn, a valve can be fitted here. (This can be useful on the 1514 machine when wrapping rectangular bales.)
- V15 Check valve**
This prevents oil flowing in from the Assembly block.

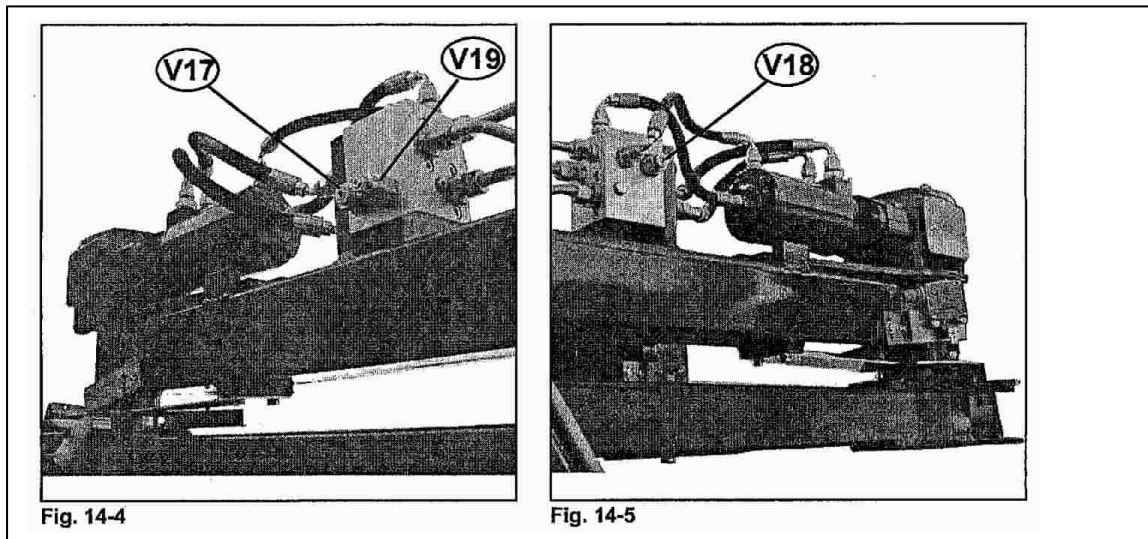

Fig. 14-4

Fig. 14-5

14.4 WRAPPING ARM BLOCK

The wrapping arm block is fitted to a flange on the tower, and contains 4 valves. (On TWIN machines there is an additional electro-magnetic reversing valve, V35). When the wrapping arm starts the oil pressure releases the brake. When the brake is operated there is however a need for a slight delay here so as to prevent the wrapping arm stopping too abruptly. This is achieved by a nozzle which is fitted in the hexagon nipple of the brake.

V16 Check valve (VRC 6.)

This prevents the oil flowing back to V10. It is fitted inside the block and can only be reached by removing the entire block from its mounting.

V17 Safety valve on the plus side (LPC 6.)

This makes the wrapping arm stop smoothly and prevents the build-up of high pressure on the motor's outflow side when the arm stops. The valve releases oil from the outflow side of the motor into the inflow side.

V18 Safety valve on the minus-side (LPC 6.)

This limits the maximum torque on the wrapping arm. The valve releases excess oil into the motor's outflow side. It is adjusted so that the traction out on the wrapping arm is approximately 35 kilo.

V19 Holding valve (Over center valve) (CP 440-1.)

This valve regulates the oil flow out the outflow side to maintain a constant pressure on the wrapping arm motor. This makes the motor run evenly so the brake does not have to be operated even if the wrapping arm runs a bit "downhill" (when the machine is wrapping while on a slope).

V35 Reversing valve (TWIN models) (LC1-A11A) (Electric cable no. 14) (Fig14-6)

When a TWIN machine has completed a wrapping sequence, the wrapping arm reverses before the next bale. At this point the computer sends a signal to V35 which reverses the oil flow to the wrapping arm motor and so makes the wrapping arm reverse. When the switch on the revolution counter (9) gives the signal, the wrapping arm stops again.

It is therefore very important that the switch and the transmitter are correctly adjusted.

14.5 THE ASSEMBLY BLOCK (See fig. 14-7.)

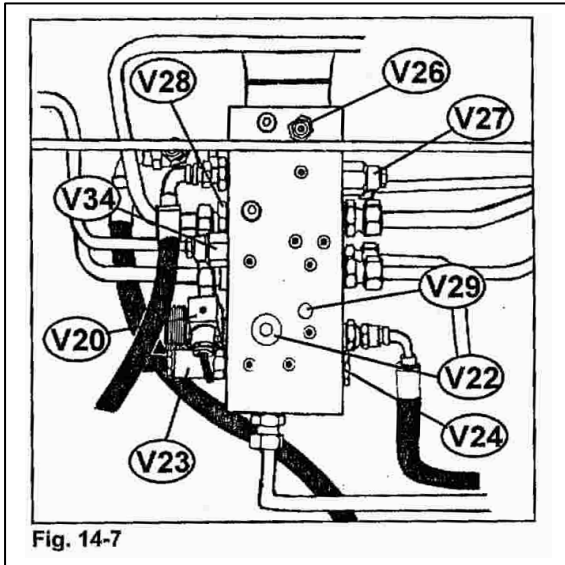

Fig. 14-7

The assembly block contains all the valves which control and regulate the various functions concerned with loading and off-loading the bales.

V20 Selector valve (CP 520-1.) (Electric cable no. 11.)

When the width between the rollers is reduced (while loading) and they reach the position at which the switch on the left Roller arm has been adjusted to trip (see section 10.1), this valve will then be activated. It directs all the oil to the width cylinder, and the bale is lifted right up into the machine. It is also activated by ROLLER WIDTH OUT.

V22 Roller operation valve (Sequence valve.) (CP 240-8L.)

When the oil pressure reaches the preset level, this valve opens to direct oil to the left-hand roller motor while loading. It is preset at the factory to 120 bar. The pressure is measured in the hose between the tractor and the bale wrapper when 'roller width in' is activated and the maximum clamp pressure switch is not operating.

V23 Clamp valve (CP 230-2.)

This keeps the clamp pressure in the width cylinder constantly at the preset level. It is preset at the factory to 70 bar. When the pressure rises higher than this, the valve closes and the oil is directed to the left-hand roller motor via V22. The roller motor will then rotate in under the bale and help to load it up.

V24 Check valve (CP 100-1.)

This valve closes when full clamp pressure is reached. This is to prevent the oil pressure "leaking out" through V23.

V26 Holding valve (CP 440-1.)

This maintains the current pressure on the minus side of the width cylinder when it is not activated. It also controls the pressure for the disconnecting function.

V27 Holding valve (CP 440-1.)

This maintains the current pressure on the plus side of the width cylinder when it is not activated.

V28 Check valve (CP 100-1.)

This valve closes when wrapping is in progress. This is to prevent the oil "leaking out" through V22.

V29 Pilot controlled check valve (CP 450-2.)

This lets the oil flow past during loading. It is opened by the force of the oil pressure flowing to the minus side of the width cylinder.

V34 Brake valve for the roller motors (CP 440-1.)

This regulates the oil flow through the roller motors. It senses the pressure on the right-hand roller motor (Number 2). If a rectangular or square bale started to keel over, the weight of the bale would turn the rollers. This would lower the pressure in the motor and the V3 throttle and the motor will brake.

14.6 DOUBLE-DRIVE BLOCK (Additional equipment, standard on 1514)

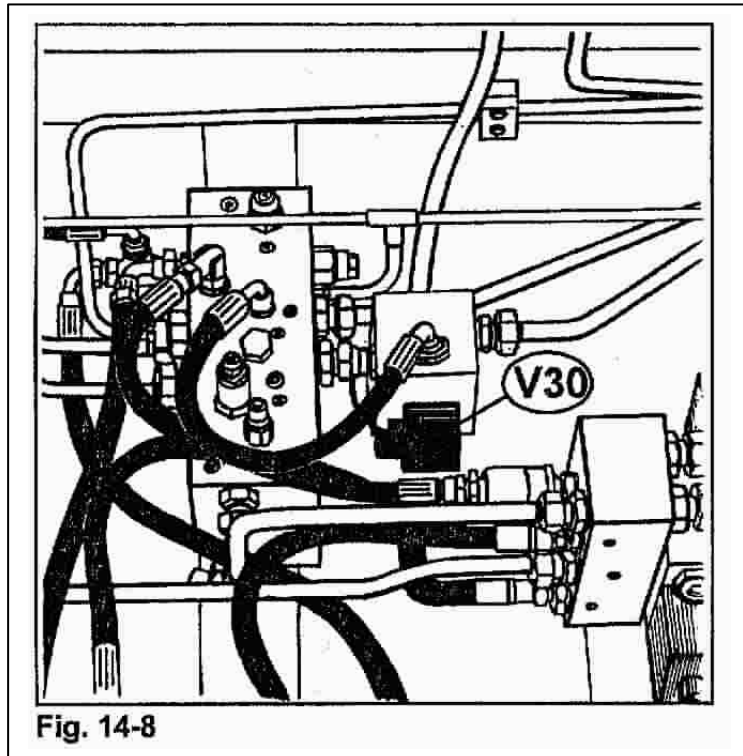

Fig. 14-8

A double-drive system can be supplied as additional equipment for the Auto Wrap 1510/TWIN machines. This rotates all the rollers during loading (with the left and right-hand rollers turning in opposite directions.) This makes the bale lift right up without the bale itself rotating.

This can be an advantage when wrapping two square bales on top of each other. The wrapping will however run somewhat slower with double-operation.

- V30 Double-drive valve (CP 520-1.)** (Electric cable no. 13.)
Electric valve which connects or disconnects the double-drive function.
This is only active when "**ROLLER WIDTH IN**" (6) is selected.

14.7 ROTATION OF BALE AFTER WRAPPING IS COMPLETED (Additional equipment, standard on 1514.)

- V36 Directional valve (LC1 E2.)** (Electric cable no. 15.) **(Not illustrated)**
The machine can be supplied with a valve, as additional equipment, which makes it possible to rotate the bale after it has been wrapped. When wrapping square bales this can be useful for moving the bale into a particular position before stacking.

The function is controlled by selecting  and keeping the button pressed in until the bale has reached the required position.



15.0 CHECK POINTS BEFORE TROUBLE SHOOTING.

In this chapter we have some general check points that have to be examined first if something is wrong with the machine. In chapter 17.0 we have a more detailed trouble shooting.

There are three basic assumptions that have to be fulfilled if the machine shall function properly:

1. The oil pressure from tractor should be 180 bar.
2. The return flow of oil has to be as free as possible, max. 10 bar counter pressure.
3. Enough electric power to all functions.

15.1 OIL PRESSURE.

In order to control that the oil pressure into the machine is high enough, there has to be applied a gauge to the oil pressure hose, for example on the quick coupler.

If the pressure is less than 180 bar, there will be less power for the functions. The first place you check this is on the ROLLERS OUT / IN.

OIL AMOUNT.

The oil amount that the tractor delivers must be **minimum 15 bale wrapper/minute**, but it is recommended that it is 25 bale wrapper/minute. (Max. allowed oil amount is 40 bale wrapper/minute).

REMEMBER! Large oil amount = Valves get hot. (Small oil tank = insufficient cooling).

15.2 RETURN PRESSURE.

The return pressure can be too high. With high return pressure the machine's functions will get less power. High return pressure means also that you need more power to operate the valves.

MAX. ALLOWED COUNTER PRESSURE IS 10 BAR.

If you are in doubt about the counter pressure, arrange a "free return" directly to the tank.

If the return pressure goes over 105 bar, the emergency outlet valve, (S2), will open and let the oil out on the ground through the outlet tube. (See chapter 14.4).

15.3 ELECTRIC POWER.

It is important to check that all function gets enough electric power. If not, some, or all functions may fall out.

Is the battery voltage high enough?

The control box display indicates the voltage being supplied if this is too low.

If the voltage falls below 10 volts this is treated as an interruption of the power supply and all functions stop.

Are the cables correctly connected to the battery?

Follow directions in chapter 4.9 and 13.0.

Is the connection between battery cable and control unit OK?

Clean off the poles and check that the plug comes correct in place.

Is the connection between control unit and machine OK?

Change contacts if any doubt about the condition.

Is the fuse on the battery cable OK?

In addition to the fuse on the battery cable, there is a fuse inside the remote control. This is 10A, and secures the current to the magnet valves.

PLEASE CONTACT YOUR DEALER IF YOU ARE IN DOUBT OF ANYTHING.

(Remember always to give your dealer the serial number and production year of your machine when contacting dealer and when ordering spare parts).

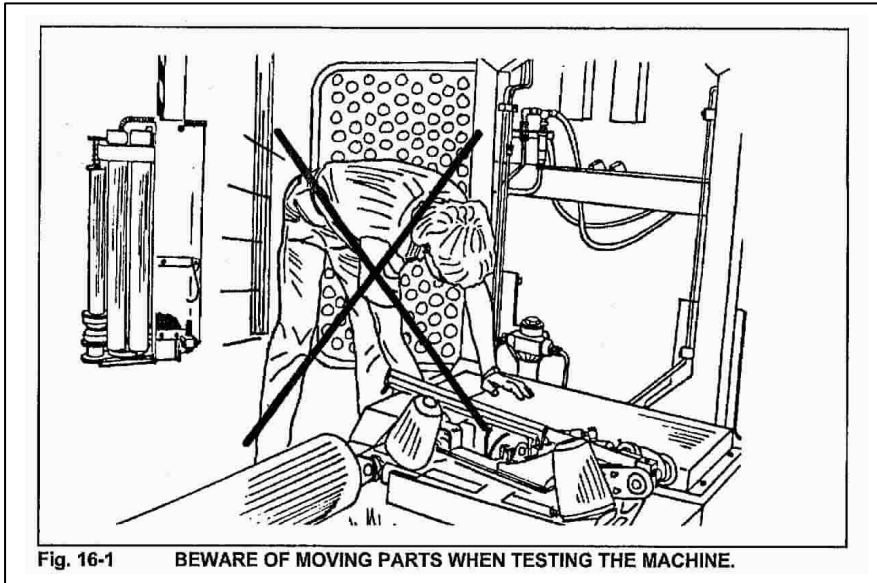

16.0 PROCEDURE OF TROUBLE SHOOTING.

16.1.1 SOLENOID VALVES.

When you shall check if the solenoid valves get electric power, you do this in the following way:

1. Unscrew the nut that holds the solenoid.
2. The solenoid is easy to move without electric power.
3. Push the current function on the remote control. If the solenoid gets power, it will be difficult to move, it "sticks". This is the best and easiest way to check if the solenoid valve gets electric power. Another way is to hold a screwdriver up to the magnet. If it "sticks", the solenoid gets electric power.

Voltage at any one valve can also be measured with a voltmeter, but the solenoid must be in contact so that it draws current.

For reliable functioning the voltage should not be lower than 11.5 volts, even if the solenoid valve will often work with a lower voltage.

16.2 Applies only to the solenoid valves on the control block. (See section 14-2.)

If the electric supply is in order and one of the functions fails, the reason can be that dirt is stuck in the valve that prevents the spool sliding to open and/or close.

Try to maneuver the function manually, by pressing the point of a screwdriver into the end of the valve housing. **At the same time the corresponding switch on the control unit has to be operated to get electric power to the master valve.** If the function is working again after this, the dirt has been pushed out in the oil system and the machine can be operated normally again.

16.3 MASTER VALVE.

To get anything to work, the master valve, (pos. 7, fig. 14-1), must have electric power. If there is no power supply to this valve, the oil goes straight back to the tank, and nothing happens.

(V2 must always have power when attached to a tractor with closed center hydraulics.) (See also section 14.1 and 16.1.)

16.4 EMERGENCY STOP*.

The emergency stop* is constructed so that the electric circuit must be closed to be able to start the machine. As soon as it's broken, the machine will stop. "E-STOP ACTIVE" will flash on the control-units' display by. (See chapter 7.1). When the emergency stop* is activated, there should be measured 4 volts over the emergency stop*-switch.



	TROUBLE DESCRIPTION	SYMPTOM CAUSE / SOLUTION
LOADING	"Roller width IN does not work when the machine has no load."	<p>The solenoid valve (no. 3) is not receiving power or there is dirt in the valve. See section 16.1 and 16.2.</p> <p>V24 is defective. Clean the valve or replace if defective.</p> <p>Either the clamp valve (V23) or the holding valve (V27) is not opening for the oil flow. Replace defective valve or have it tested by your dealer.</p>
	"The left-hand roller motor does not rotate when a bale is loaded."	<p>The roller-operating valve (V22) is not opening. Check, adjust or replace if defective.</p> <p>The maximum clamp pressure switch is defective or wrongly adjusted. Check, adjust or replace defective switch.</p> <p>Leak in the rotation-stop valve (V14). There can still be a leak even if there is only a blind plug fitted here. Clean or replace defective valve.</p>
	"The wrapping arm rotates the wrong way when loading."	<p>Leak in check valve (V15). Clean the valve or replace if defective.</p>
	The bale cannot be loaded."	<p>Maximum clamp pressure switch must be adjusted. (Section 10.1.) The clamp pressure must be increased or reduced using V23.</p>
WRAPPING	"The wrapping arm will not turn."	<p>The transport safety catch has not been released .See section 4.12.</p> <p>The solenoid valve (no. 5) is not receiving power or there is dirt in the valve. See section 16.1 and 16.2. Clean the valve or replace if defective.</p> <p>The volume-controlling valves for the wrapping arm (V10/V12) are closed or defective. See section 8.0 and 14.3. Clean valves or replace if defective.</p> <p>The brake is not releasing properly. Mechanical cause. Repair or replace brake.</p> <p>Wrongly adjusted or defective safety valves (V17/V18). Adjust, clean or replace valve.</p> <p>Defective wrapping arm motor. Replace motor.</p>
	"The wrapping arm only turns slowly."	<p>The two-stage valve (V11) is not receiving power or is defective. See section 14.3 and 16.1. replace defective valve.</p> <p>The holding valve V19 is not opening. Clean the valve or replace if defective.</p> <p>The volume-controlling valves (V12) are wrongly adjusted. See section 9.0.</p> <p>The brake is not releasing properly. Mechanical cause. Repair or replace brake.</p>



"The speed of the wrapping arm cannot be adjusted."	The volume-controlling valves (V10/V12) are defective or full of dirt. Clean valves or replace if defective.
---	--

	TROUBLE DESCRIPTION	SYMPTOM CAUSE / SOLUTION
WRAPPING	"The rollers slide apart from each other during loading."	The fault is probably in the holding valve (V26). Clean the valve or have it tested by your dealer. If necessary replace defective valve.
	"The wrapping arm turns but the rollers do not rotate."	The volume controlling valves for the rollers (V9/V13) are closed or defective. See section 9.0 and 14.3. Dirt in one of the following valves: V14, V28 or V29. This would cause the oil to leak back to the tank. Clean the valves or replace if defective.
	"The cutter does not function."	The solenoid valves (nos. 1 and 2), are not receiving power or there is dirt in the valves. See section 16.1 and 16.2. The cutter cylinder is defective. Replace. The cutter lifts quickly but drops slowly. The double pilot-controlled check valve is defective. Replace.
	"The cutter will not grip the film."	The pressure in the cutter cylinder is dropping. The fault is probably in the double pilot-controlled check valve. (See section 14.2.) Replace defective valve or have it tested by your dealer. The fault could also be that the check valve that is fitted below the pilot-controlled check valve is leaking. Clean this valve or replace it with a new one.
	"The cutter will not release the film when the machine is tested without a bale loaded."	When the machine is running idly, i.e. the wrapping arm and rollers are turning without a loaded bale, it can happen that there may not always be sufficient extra pressure to open the pilot-controlled check valve (section 14-2) if the cutter is closed with full pressure. This can be avoided by not leaving the cutter closed with full pressure. Therefore press the "CUTTER OPEN" (5) button briefly. (This problem cannot occur when a bale is being wrapped on the machine.)
OFFLOADING	"Roller width OUT does not work."	The solenoid valve (no. 4) is not receiving power or there is dirt in the valve. See section 16.1 and 16.2. The holding valve (V26) is not opening. Replace defective valve or have it tested by your dealer.

There are 3 basics which must **ALWAYS** be followed if the machine is to function correctly

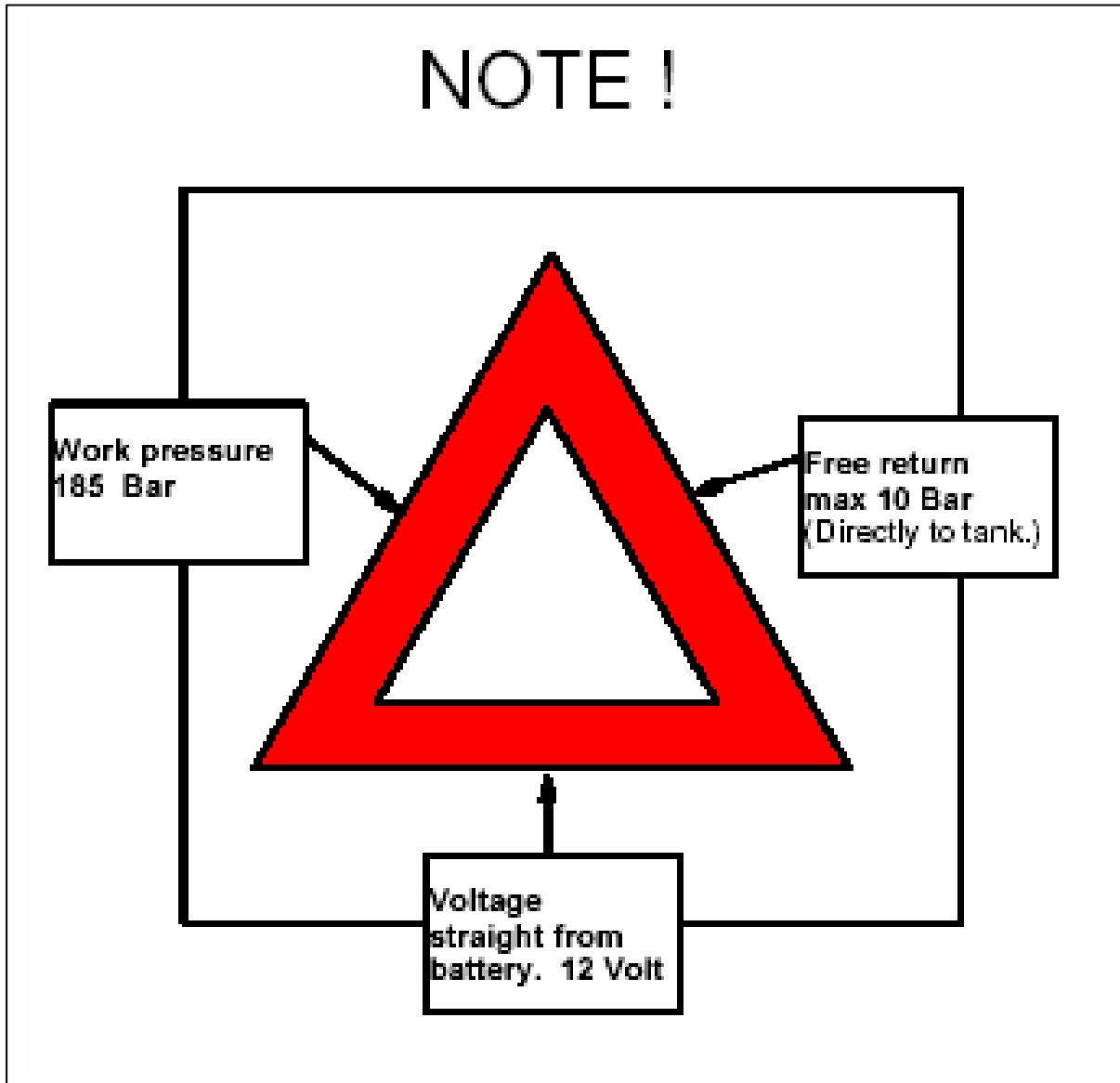

OUTPUT	FUNCTION
1	C&S OPEN
2	C&S CLOSE
3	ROLLERS IN
4	ROLLERS OUT
5	WRAP FWD
6	2 SPEED VALVE
7	MASTER VALVE
8	CLOSED CTR
11	DOUBLE DRIVE
12	Freewheel
14	REVERSING VAL.
15	ROTATION STOP

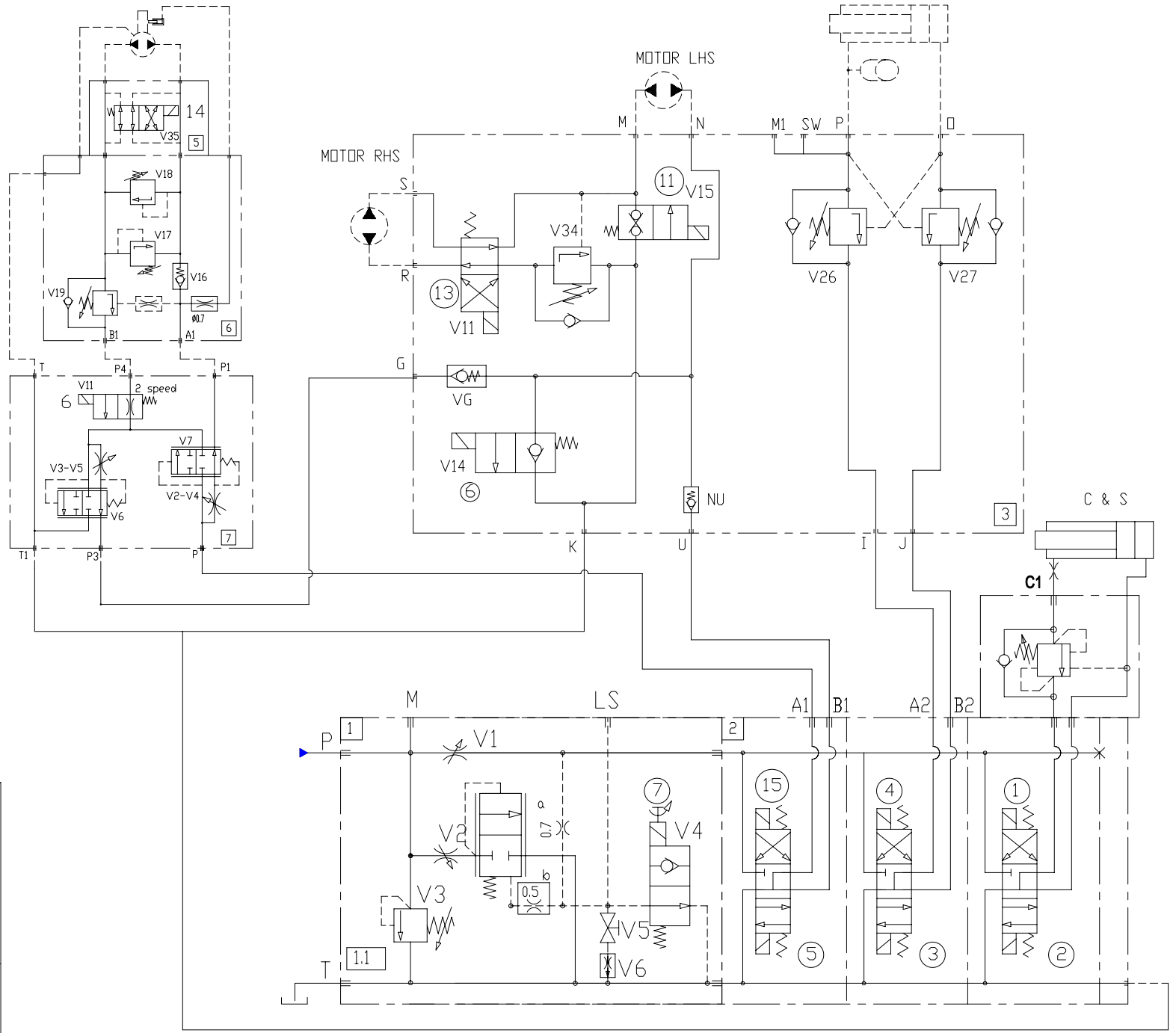

1510-14 HYDRAULIC CIRCUIT 06

Pos.	Part No.	Description
1	1508251	LS ENTRY BLOCK
2	1508250	ENTRY & CONTROL BLOCK
3	1508150	ASSEMBLY BLOCK
5	1308170	REVERSING VALVE
6	1308150	TOWER BLOCK
7	1508020	ADJUSTING BLOCK 1510/14



EC DECLARATION OF CONFORMITY

ACCORDING TO DIRECTIVES 89/392/336 /EEC AS AMENDED

Manufacturer:

**TANCO ENGINEERING Co LTD
BAGENALSTOWN
CO CARLOW
IRELAND**

CERTIFIES THAT THE FOLLOWING PRODUCT:

TANCO AUTOWRAP

MODEL: 1510/14

SERIAL NO:

To which this declaration relates, corresponds to the essential requirements of the Directive 89/392/336/EEC as amended.

To conform to these essential health and safety requirements, the provisions of the following harmonized standards were particularly considered:

EN 292-1,2, EN 294, EN 1152, prEN 703, prEN 811, prENI553, prEN 982.

DATE ____.

SIGNATURE:

**Andrew Deasy
TECHNICALMANAGER**