

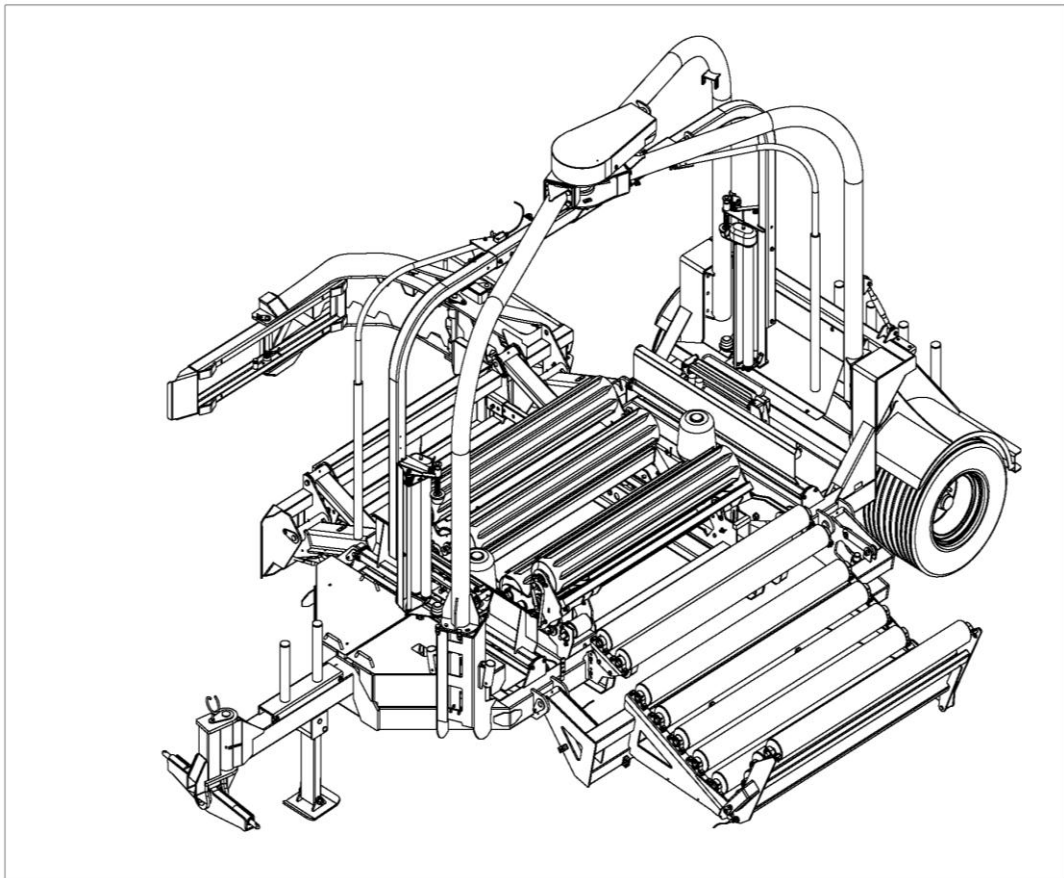

1814
OPERATORS HANDBOOK
1814-M0513



Tanco Autowrap Ltd.
Royal Oak Road
Bagenalstown
Co. Carlow
Ireland

Tel.: +353 (0)5997 21336
Fax: +353 (0)5997 21560
E-Mail: info@tanco.ie
Internet: www.tanco-autowrap.com



USER'S MANUAL

AUTOWRAP 1814

CHAP.	CONTENTS	PAGE
1.0	INTRODUCTION	4
2.0	SAFETY PRECAUTIONS	7
3.0	SETTING UP / MOUNTING OF THE MACHINE	13
4.0	ELECTRICAL SUPPLY	15
5.0	EMERGENCY STOP*	16
6.0	MOUNTING OF PLASTIC FILM	17
7.0	CONTROLLER	19
8.0	WRAPPING ARM SPEED SETTING	30
9.0	FILM OVERLAP SETTING	30
10.0	OPERATION INSTRUCTION	29
11.0	PERIODIC MAINTENANCE	36
12.0	ELECTRIC CIRCUIT DIAGRAM	38
13.0	DESCRIPTION OF THE HYDRAULICS	43
14.0	CHECK POINTS BEFORE TROUBLE SHOOTING	47
15.0	PROCEEDURE OF TROUBLE SHOOTING	49
16.0	TROUBLE SHOOTING	50
17.0	HYDRAULIC CIRCUIT	52
18.0	DECLARATION OF CONFORMITY	54

AUTOWRAP 1814 S and Arc Models

(Single Wrap Arm version shown here)

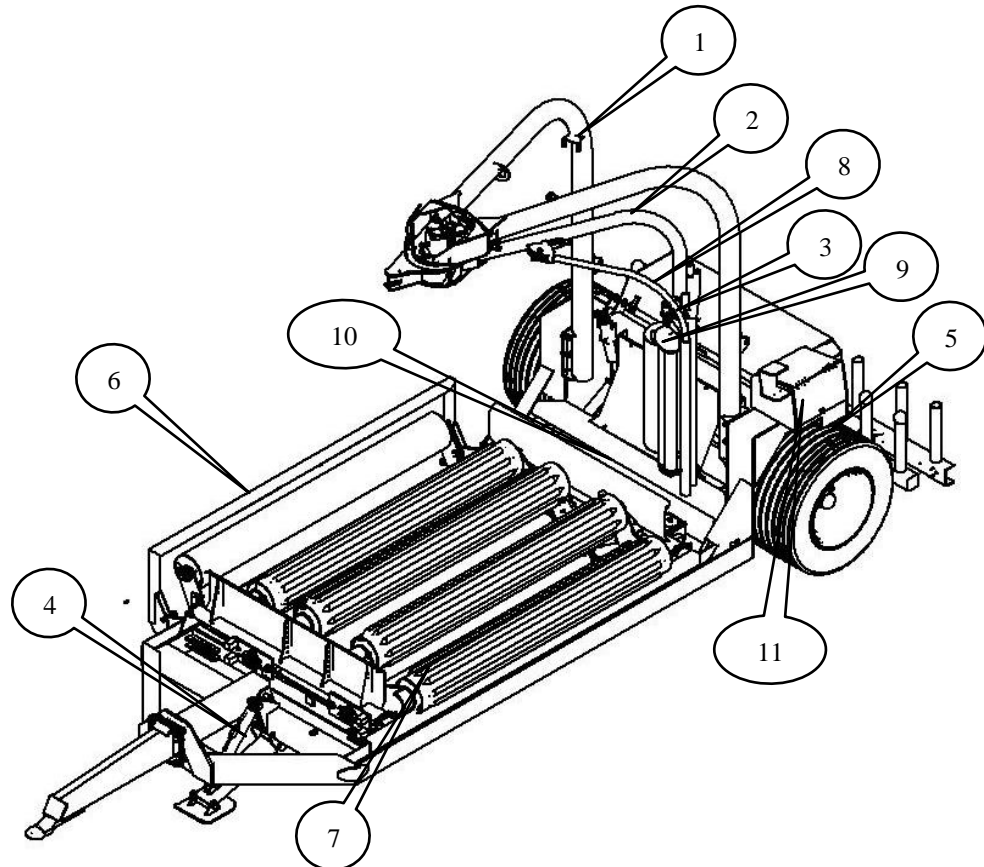

1. Tower
2. Wrap Arm
3. Power Pack (S Model)
4. Hydraulic Jack
5. Hydraulic axle height cylinders
6. Unloading Mat. Optional roller conveyor.
7. Rocking rollers.
8. E-Stop Arm
9. Dispenser
10. Film Cut and Start
11. Controller Enclosure

AUTOWRAP 1814 LA Model

Bale wrapping machine

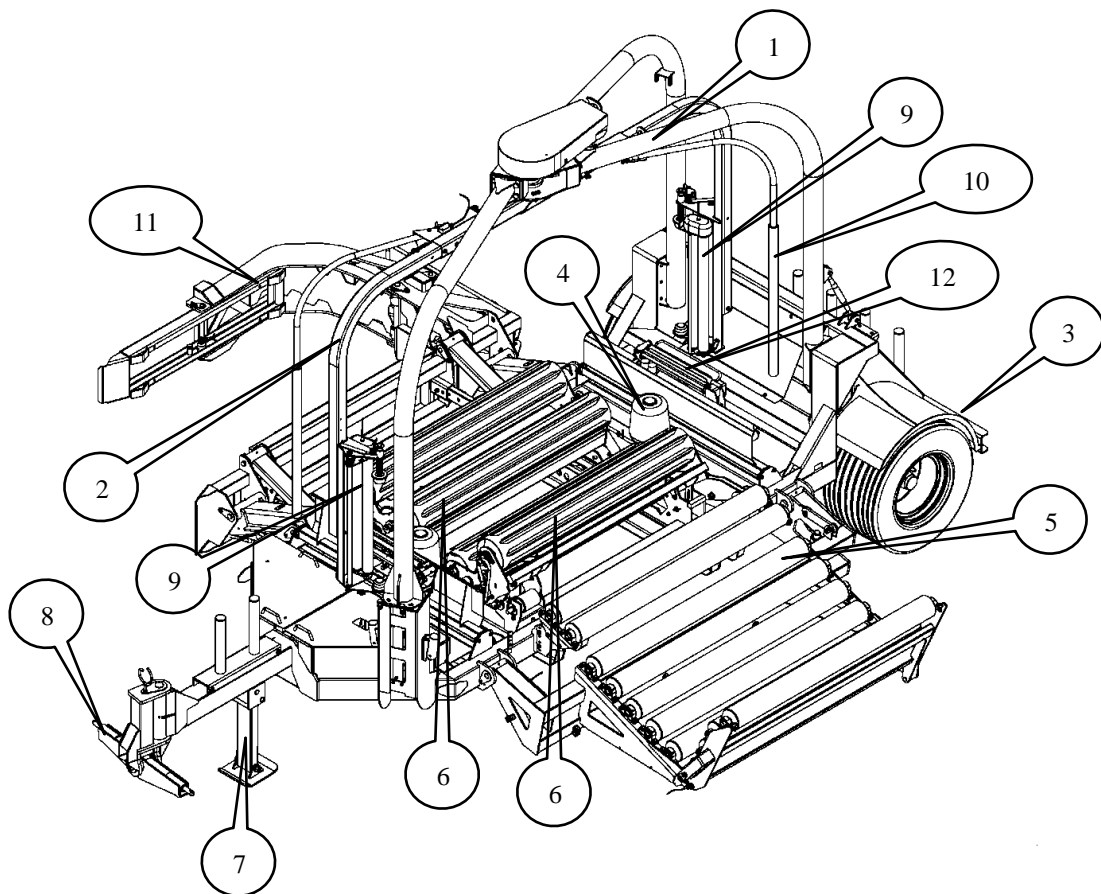

- | | | | |
|----|-------------------------|-----|--------------------|
| 1. | Tower | 7. | Stand |
| 2. | Wrap arm | 8. | Linkage bar |
| 3. | Bumper | 9. | Dispenser |
| 4. | Cone rollers (optional) | 10. | E-stop arm |
| 5. | Un-loading conveyor | 11. | Load arm |
| 6. | Rocking rollers | 12. | Cut and start unit |



1.0 INTRODUCTION.

There are three models on the 1814 Autowrap range. The ARC and S models are designed for static operation; the LA model is self-loading to operate in the field. All models can be operated fully automatically. The static models have the controller mounted in an enclosure on the machine; this can be operated by radio remote control from the loading tractor. The LA model has the controller in the tractor cab.

The 1814 is equipped with a patented, special mounting for the rollers, which enables the machine to wrap round* & square bales.

The 1814 can wrap both square and rectangular bales, from 47 x 80 to 120 x 120 x 190 cm long. It can take bales of up to 1500 kg. It can also wrap round bales of up to \varnothing 1500 mm.

This machine has been in operation since 2007; customer demand has enabled us to develop this well adapted machine for the market.

This manual is meant to explain how the 1814 is prepared, mounted, operated and how it works, and along with the spare part's list be a reference for maintenance and troubleshooting. So take good care of this book, it is a part of the machine.

Read carefully through this manual, and specially chapter 2.0, safety instructions, before starting the machine, and follow the instructions thoroughly. If problems should occur, ask your dealer for advice before you make the problem worse than it is. See also chapter 13.0, conditions of warranty.

TANCO AUTOWRAP LTD. reserves the right to alter the product and/or its technical specifications without prior notice and without this entitling any alterations to previously supplied products.

© All rights in pursuance of the Copyright Act shall apply, and any reproduction of the contents of this booklet, in whole or in part, is forbidden without the permission of TANCO AUTOWRAP LTD.

Reservation is made for possible printing errors.

*Optional 'round bale kit' required for wrapping round bales.



1814	
Height in working position	3400 mm
Width, min. / max. (ARC , S)	2440 / 3215 mm
LA	2440 /6950
Length, min. / max.	2540 / 3425 mm
Weight (ARC , S)	2550kg
LA	4500 kg
Wrapping arm speed, recom.	25 rev. per minute
Wrapping arm speed, max.	30 rev. per minute
Wheel size ARC , S	480/45-17
LA	500/50-17
Bale size, max.	120x120x190
Bale weight, max.	1500 kg
Capacity	Approx. 50 bales per hour
Pre-stretcher	750 mm
Oil pressure / amount, min.	175 bar / 50 litres/minute
Electric connection	12 V DC



2.0 SAFETY PRECAUTIONS.

TANCO AUTOWRAP LTD. does not take the responsibility for damages that may occur on machine, persons or other equipment, because of the machine NOT being used as described in this manual, or because of the safety precautions NOT being followed.

2.1 SAFETY EQUIPMENT.

Before using the machine, make sure that all guards and covers are securely fitted. The machine must not be operated if a function does not work as described later in this manual. (See chapter 2.4).



The AutoWrap 1814 is equipped with an "EMERGENCY STOP" on the wrapping arm. This device stops all functions as quickly as possible, but is by definition not an emergency stop, because it does not interrupt the feed. Nevertheless it has an equivalent function, so we have decided to call it an EMERGENCY STOP in this book.

2.2 BECOME FAMILIAR WITH THE OPERATIONS OF THE MACHINE.

If you are unsure how to operate the machine properly, either use of or maintenance to your Auto Wrap, please contact your Auto Wrap dealer.

2.3 IMPORTANT!

**MAKE ALWAYS SURE THAT NOBODY IS IN THE HAZARD
AREA OF THE WRAPPING ARM WHEN THE MACHINE IS IN USE.**

**THE MACHINE MUST NEVER BE OPERATED BY PERSONS WHO DO NOT KNOW
ENOUGH ABOUT HOW TO SAFELY OPERATE THE MACHINE, OR BY PERSONS
UNDER 16 YEARS OF AGE.**

2.4 DANGEROUS AREAS.

TANCO AUTOWRAP LTD. has given the safety to the operator the highest priority, but it is still impossible to secure oneself of every danger area on the machine. Therefore we will now go through some of the dangers that can occur when using the Auto Wrap bale wrapper. The 1814 is a large machine with many moving parts. As such there are significant danger area's associated with it and it is vitally important that the operator is conscious of these and remains vigilant at all times when operating the 1814.

1. IMPACT OF THE WRAPPING ARM.



During the wrapping process the arm rotates with a speed of 20-27 revolutions per minute around the bale. On the arm there is mounted a film Dispenser unit with a plastic roll. The Dispensers can give a person serious injuries if one comes to close to the working area of the wrapping arm. To reduce this danger we have mounted an emergency stop* device on the wrapping arm, this stops output for the wrap arm and should stop the wrap arm within two feet of movement when something comes in the way of it. **It is very important that this protection always works and that it should not under any circumstances be disconnected.**

(See more about the emergency stop* in chapter 5.0).

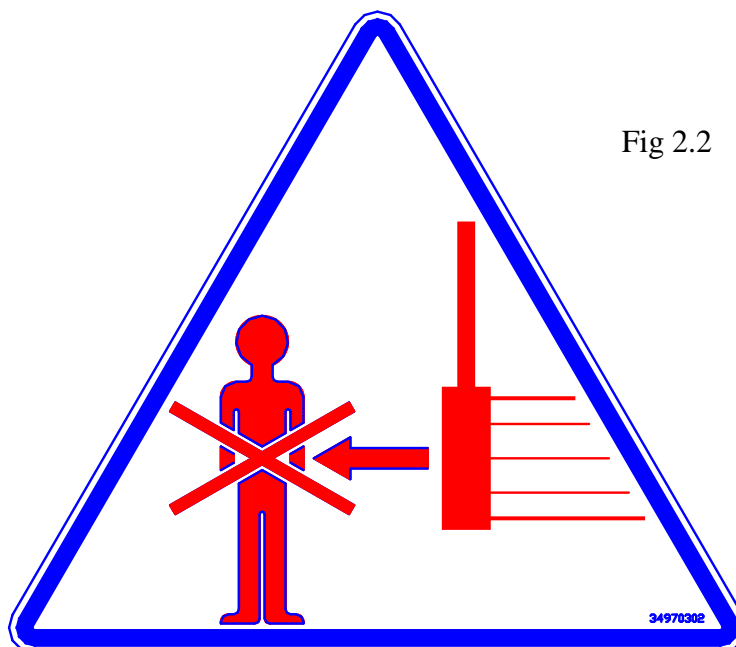
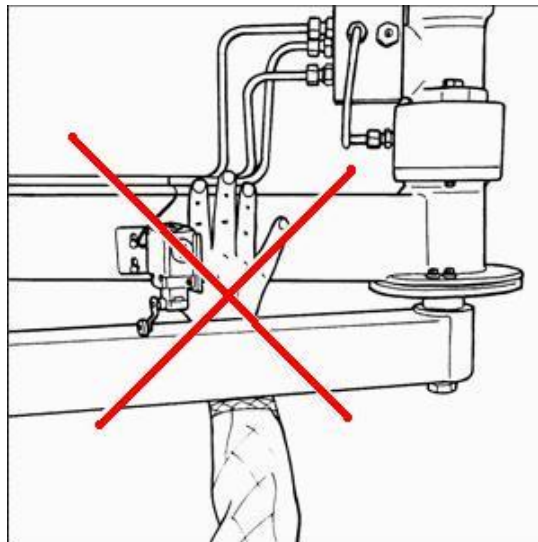

Fig 2.2

2. CRUSH HAZARD BETWEEN THE TOWER/CHASSIS AND THE WRAPPING ARM.



As earlier explained, we have a wrapping arm with a Dispenser and a plastic roll. The wrapping arm passes the main frame during each rotation. Here there is a risk of crushing if a person stands too close to the main frame when the wrapping arm passes. The distance between the main frame and the wrapping arm is not large enough to give room for a person. The clearance between the Dispenser and the Chassis there is also a crush hazard.



3. CRUSH HAZARD BETWEEN THE TOWER AND THE WRAPPING ARM.



During the main wrapping process the wrapping arm rotates around the bale. Every time the wrapping arm passes the tower/chassis, there is a crush hazard that can be dangerous for the fingers/ arms or bodies. The distance between the stationary and the wrapping arm is between 25-40 mm.



Fig 2.3

4. **CRUSH HAZARD BETWEEN THE ROLLERS AND THE MAIN FRAME.**



When adjusting the width of the rollers there is a danger of being trapped and squashed. **Keep away from this area**, fingers and feet also. (See fig. 2-3).

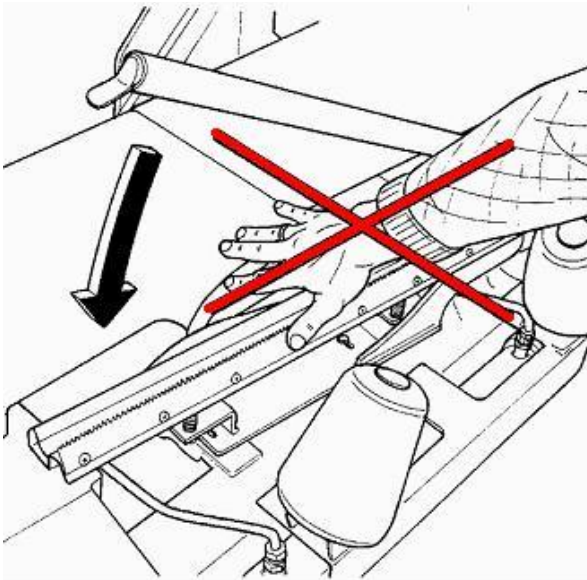

Fig 2.5

5. **CRUSH HAZARD CAUSED BY CUT AND START SYSTEM.**



At the end of the wrapping process the plastic is held tight & cut from the bale. It's held ready for the start of the next wrapping process. When the cutter arm moves down to hold the plastic, there can occur a trap danger between the cutter arm and the cutter holder. The cutter blade that perforates the plastic is very sharp, so keep hands away from the cutter. (See fig. 2-5).

6. CRUSH HAZARD BETWEEN THE ROLLERS.



When the rollers on the machine are moved together, there is not enough space for a person between the rollers. Here there is a danger of being squeezed, so make sure that nobody is between the rollers when they are moved together. (See fig. 2-6).

Note that the rocking rollers can rotate and even if they are in the level position they can drop suddenly. There is a serious risk of crushing associated with this. Never stand on the rollers or stand between or lie under them. If you need to work in this area always ensure that everything is in a safe position. i.e rollers are dropped and fully opened and power supply is disconnected

7. CRUSH HAZARD ON THE LOAD ARM.

Always ensure that when you are operating the load arm there is nobody in the operating area of it as it could cause serious injury, either by crushing or squeezing.

8. HAZARD ON THE CONVEYOR.

Always ensure that when you are operating the unloading conveyor there is nobody in the operating area of it as it could cause serious injury. If the optional rotate conveyor is fitted there is a risk of getting crushed when it is closing.

Note: The rollers on the conveyors and the two mounted on the chassis between the rocking rollers and the conveyor are free rolling. Never stand or sit on them as you are likely to lose your balance and cause injury to yourself.

2.5 LOCKING THE CONVEYOR.



When the machine is not in use, make sure the unloading conveyor is raised and the parking bracket is connected. If this bracket is not connected, the conveyor can creep down, causing a hazard on the road or to items the beside the machine.(See fig. 2-7).

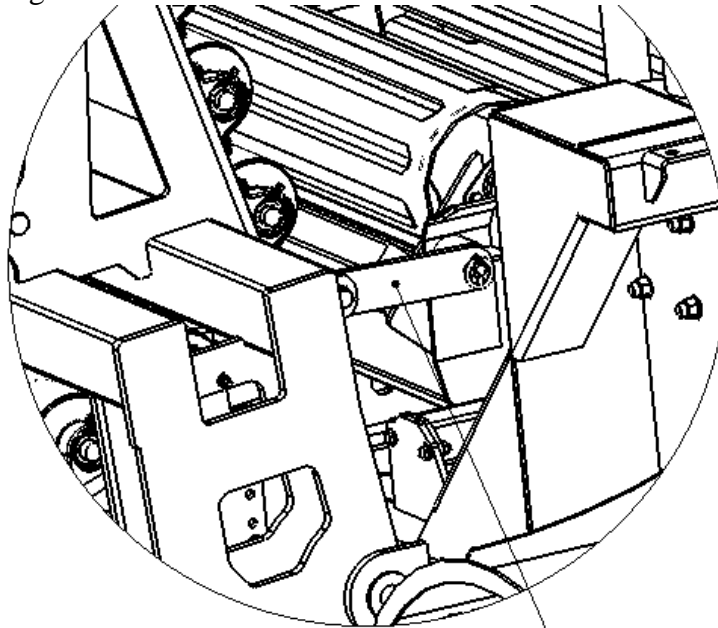

Fig 2.7

Parking bracket

Connecting heavy working implements often has an overall negative effect on the tractor's driving and braking capacity. When transporting on the road always ensure the machines hydraulic brakes are connected to the tractor and that they are functioning correctly.

2.6 TRANSPORTING.

When transported on a public road there are certain safety measures that must be taken:

1. Move the wrapping arm into the transport position using the controller. (See 10.)
2. Close the grab fully and raise the load arm fully. (See 10.9)
3. Raise the unloading conveyor and secure with the parking bracket. (See section 2.7)
4. Ensure machines lights are connected and working correctly.
5. Cut the flow of oil to the machine by disengaging the tractors spool valve and cut the power to the controller by pressing the Red Button on the controller.

3.0 SETTING UP / MOUNTING OF THE MACHINE.



Be careful! There is a danger of being crushed when working implements are mounted and connected. Carry out the mounting procedures slowly and carefully, and use separate and approved lifting equipment to make the work easier. See section 2 on safety regulations and pay attention to the various safety decals displayed on different parts of the bale wrapper.

3.1 HINGED TOWER.

Because of the freighting of the machine, AUTO WRAP 1814 is sometimes delivered with the tower hinged down. Raise tower by lifting using the lifting eyes. Fit 10 M16 x 50 bolts but do not tighten. Fit the dispenser to the wrap arm. Measure the height from the bottom of the dispenser to the chassis. Rotate the arm around ½ a turn and measure again. Raise or lower the tower until the wrap arm is parallel to the chassis. Tighten up the top links on the back of the tower. Lower the lifting mechanism and check again. If necessary lift again and tighten top links. Then fit the tower support going to the front of the machine.

Tighten all bolts and lock top links and after several hours' use, tighten all the bolts once again.

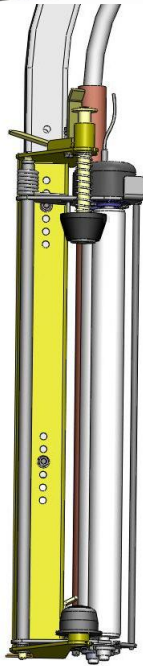

Fig 3.4

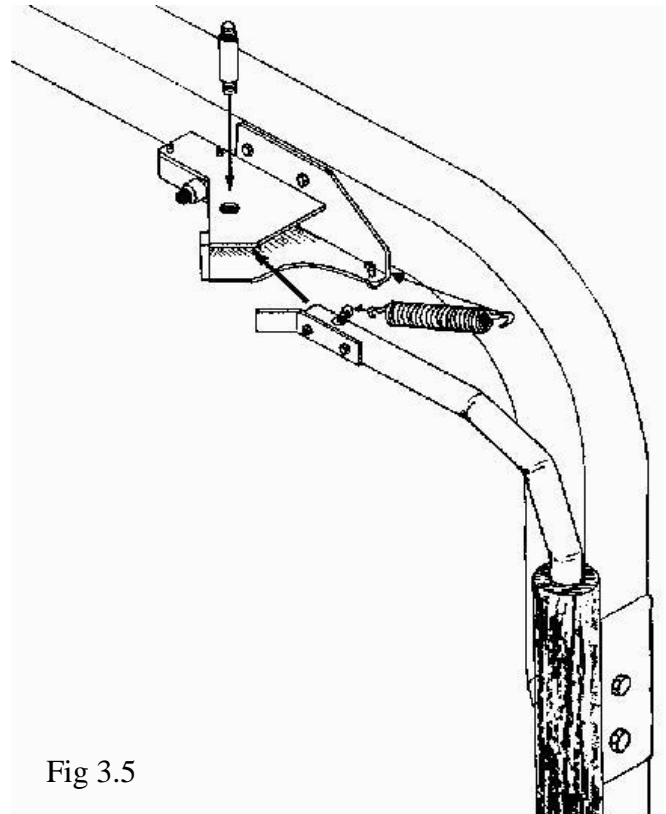

Fig 3.5

MOUNTING OF DISPENSERS

The dispensers are mounted using two M12 bolts. The dispenser height should be such that the plastics is being applied as close to the centre of the bale on the end as possible. Generally we recommend that they should be fitted in the lowest position possible (where the plastic just passes over the cut and starts. The height of the bale can then be decided by the width between the rocking rollers.

3.3 MOUNTING OF EMERGENCY STOP* ARM.

The machine is equipped with emergency stop-arms on each of the wrap arms.

The releasing arm for the emergency stop component must be mounted.

Put the arm into the bracket and mount the hinge bolt. Replace the washers and tighten the locking nuts. (See fig. 3-5).

The return spring is to be fastened between the eye bolt on the arm and the eye bolt on the bracket.



4.0 Electrical supply

The electric supply for the machine's control unit and electro-hydraulic components should come **directly from the tractors' 12 volt battery** .

The electric wires from the battery must have an area measurement of min. 2,5 mm².

Connection of other contacts on the tractor can cause risk of malfunction, and is not recommended.

Never tamper or remove fuses fitted. Replace fuses with ones of the same rating.

BROWN LEADER GOES TO BATTERY PLUS POLE

BLUE LEADER GOES TO BATTERY MINUS POLE

5.0 EMERGENCY STOP.

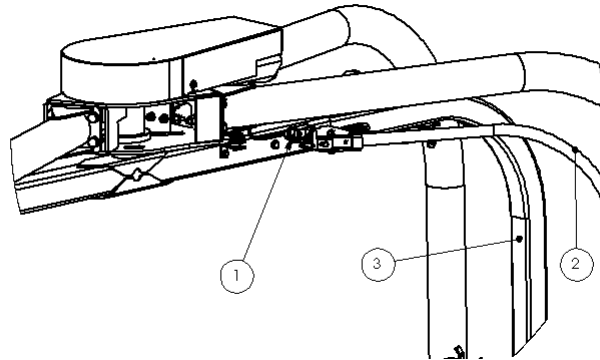

Fig 5.2

- 5.1** The machine is equipped with a safety arm (2) on the wrapping arm (3), and its operation must be tested before work itself is started.
- 5.2** The safety arm is designed to stop the wrapping arm injuring operators or objects, when starting up or during the wrapping process.
- 5.3** The emergency stop* is constructed with a "positive" connection, i.e. it has to be in full order before the machine can be started. Note that if there is a fault with the system, the wrap arm will work in manual mode but **the controller will not go into automatic.**
- 5.4** This consists of an electrical switch (1) mounted on the arm. This is wired normally open, and the actuating plate attached to the E-Stop arm rests on this and keeps it closed. The signal from the two switches and the film break sensors are fed through the centre of the wrap arm by means of a small electrical coupling. If the electrical circuit is broken, the hydraulic oil flow is cut off and all functions stop immediately. This is indicated on the control box display by 'EMERGENCY STOP'
- 5.5** Before use, this function must be tested. Start the wrapping arm, hold out an arm or any obstacle, the wrapping arm must stop within 700mm.
- 5.6** To restart the machine the obstacle must be removed and the safety guard must return to its original position. If "STOP" is pressed before "RESTART", the wrapping continues from the point in the program at which the emergency stop was activated. (See more in section 7.)

- 5.5.1 IMPORTANT: GIVEN THE VELOCITY AND MOMENTUM OF THE ARM IT IS IMPOSSIBLE TO STOP THE WRAP ARM IMMEDIATELY. THE EMERGENCY STOP ARM IS PROVIDED TO HELP REDUCE THE RISK OF SERIOUS INJURY AND GREAT CARE MUST BE TAKEN WHEN OPERATING THIS MACHINE.**



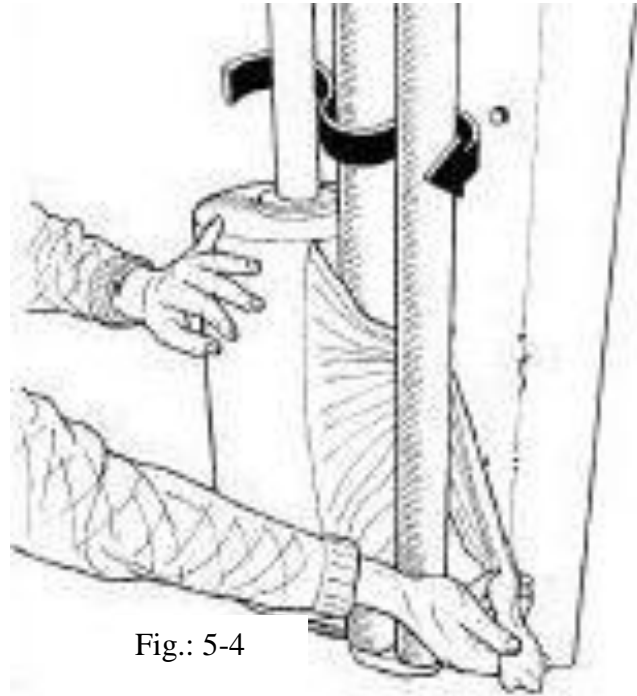
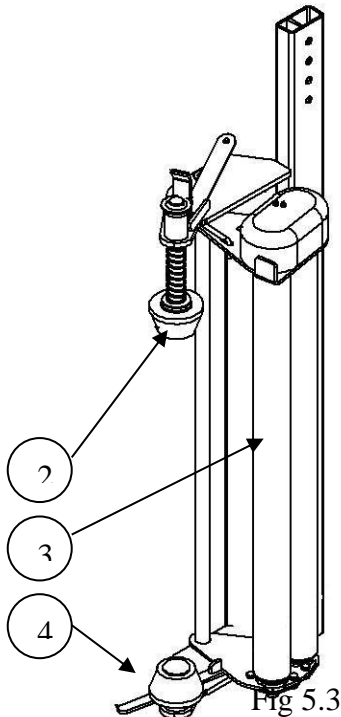

Fig.: 5-4

6.0 MOUNTING OF PLASTIC FILM.

When loading a plastic roll, first ensure the top cone (2) (See Fig 5.3) is pushed up to latched position, then push back the Stretch rollers (3) until held in position by locking catch (4).

- Place the Roll on the Bottom Cone and release the top latch (1). Beware of Fingers!
- Pull the film between the rollers on the pre-stretcher in the direction of the arrow. (See fig. 5-4). (See also the sticker on the dispenser)
- Release the locking catch and allow the rollers to lie against the roll of film. Pull the film from the roll and tie it to the bale.

6.1 The standard film dispenser is designed for 750mm film. If using 500 mm film an adaptor is required which must be ordered separately. See parts book and contact your dealer.

6.2 Height adjustment of pre-stretcher / plastic film.

The plastic film should hit at the middle of the bale wrapped, and therefore it may be necessary to adjust the height of the pre-stretcher.

6.3 Tanco Dual Stretch Dispenser

Some Tanco Autowrap machines can optionally be fitted with a patented dual stretch gear system.

This system enables a quick change of stretch levels on the Film Dispenser.

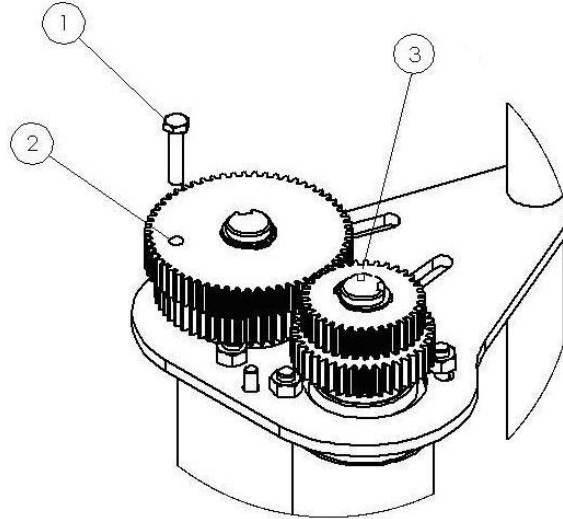

If the bolt (1) is fitted in position 2, the top set of gears provide the stretch (70%).
By removing the bolt from position 2 and fitting it in position 3, the bottom set of gears become the stretch gears giving 55% (for use in hotter climates or with square bales).
or optionally 33%

Tanco Dispenser Gear Combinations

Inner Gear	Outer Gear	% Stretch
60 Tooth	35 Tooth	70%
58 Tooth	37 Tooth	55%
54 Tooth	41 Tooth	32%



7.0 1814 Controller Manual

Contents

1. INTRODUCTION

1.1.1 IMPORTANT SAFETY INFORMATION!

1.1.2 Main operating Functions and Display

2. OPERATION

2.1 Operation in Automatic mode

2.2 Manually Interrupting an Automatic Wrapping Cycle.

2.3 Manual options in Automatic mode

2.4 Operations in Manual mode

2.5 Hand held controller

2.6 Radio Frequency (RF) Remote Control

2.7 The Display Menu.

2.8 Setting a Store Total

2.9 Resetting a Store Total to Zero.

2.10 Setting the Number of Wraps

3. Bale Type Setup Menu

4. Operator Setup Menu

5. Technician Setup Menu.

1. Introduction

The Tanco Autowrap Bale Wrap Controller enables the operator to monitor and control the operation of the bale wrapper at any stage of the wrapping cycle. The controller is designed for models : 1814 rotating-arm type wrappers.

There are 2 operating modes – Automatic and Manual. The automatic mode permits 'one-touch wrapping' to ease the workload on the operator. The controller is fully programmable to optimise wrapping performance. Bale counts are automatically logged in any one of 10 selectable memory stores, in addition to a grand total memory store.

1.1 IMPORTANT SAFETY INFORMATION!



- Please read and understand the instructions for using this controller before operating the machine.
- This controller is fitted with a pushbutton type On/Off Emergency Stop switch. Always ensure the controller is switched OFF via this switch before attempting any adjustment or maintenance to the machine.
- Please follow ALL other safety instructions given in the manufacturers' Operator Handbook for this machine.

1.2 Main operating Functions and Display

The principal instrument features and operating functions are shown in figure 1 below.

Figure 1

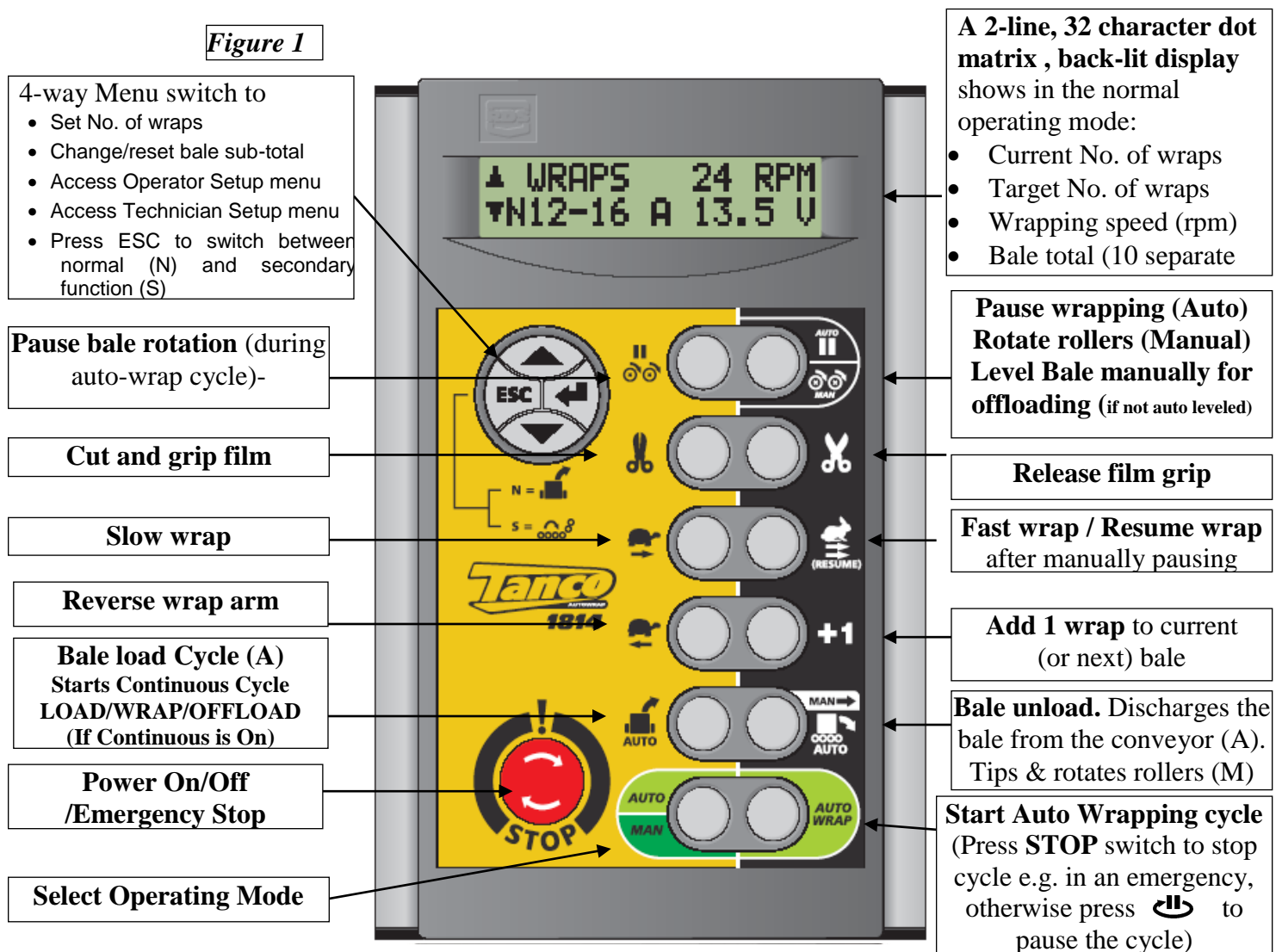





2 Operation

2.1 Operation in Automatic mode

The controller is generally used in automatic mode for ‘one touch wrapping’. The complete cycle can be broken into three main parts, Loading, Wrapping and Unloading. The default setting of the controller is for each of these tasks to be performed and then wait for the operator to activate the next operation. If **Continuous** (in Operator Setup) is set to **ON**, then the machine will run the complete cycle without operator intervention

Note: In Continuous operation the machine loads and unloads simultaneously, take great care that rotate conveyor has sufficient room to operate safely.

1. ‘A’ on the display indicates that the controller is set in Automatic mode. If not, press  to select.
2. Place a bale on top of the machine. Pressing the  button or with the controller in N(see 2.5) mode it can be done using the Hand controller. If Continuous is set to On (Operator Setup) then this button will start Loading, then when the load arm reaches down sensor Wrapping automatically starts and offloading automatically starts at the end of the wrapping cycle.
3. Press the  switch to commence the automatic wrapping cycle. The cycle is completed when the target number of wraps has been reached.
4. Once wrapping is complete the bale will be discharged onto the unload conveyors. You can now load the next bale or if you like press the  switch to unload the bale. Note if your machine has a non-rotate conveyor you must be stationary when doing this.

2.2 Manually interrupting an automatic wrapping cycle

Press the  switch to bring the wrapper to a controlled stop. Pressing the



 switch will continue the auto-wrap cycle from where it stopped.

For safety reasons, if it is necessary to work on the machine (e.g. in the event of a film break or the film running out), then it is strongly recommended that you then switch the controller off via the red stop button and disengage the machine power

source. Pressing the  switch after switching the controller back on will resume the auto-wrap cycle from where it stopped.

Unless it is an emergency situation, do not bring the machine to a stop by pressing the red stop button as this will impose unnecessary strain on the machine.

2.3 Manual options in Automatic mode

With the controller in automatic mode, the following manual functions are possible.



SLOW WRAP (not during the wrapping sequence). Press  to resume the normal fast wrap.



REVERSE WRAP ARM (only enabled outside of the wrapping sequence). Press this button to nudge the wrap arm backwards to the desired position.



PAUSE BALE ROTATION (function active during auto-wrap cycle). Hold this button to add more film to a particular part of the bale. Release the button when sufficient additional film has been applied.



BALE INDEXING (function active in manual mode). Press and hold this button to index the bale. Release the button when the bale is at the desired position.

Rectangular bales are automatically rotated till level at the end of wrapping before offloading. If the controller thinks the bale is not level then **Bale Not Level** message flashes on the screen and the sequence will stop. To continue, hold this button down until the bale is level and when the button is released the bale will automatically offload.



NOTE: The  button can also be used to rotate the rollers in manual mode but note that it also unloads the bale!

+1

ADD 1 WRAP Each time you press this button an additional wrap will be put on the current bale if the wrapping sequence is in progress, or onto the next bale if the automatic cycle has not yet been started. You can add as many wraps as required.

2.4 Operation in Manual mode

'M' on the display indicates that the controller is set in manual mode. If not, press  to select. In manual mode you have total control of every stage of the wrapping cycle. The software logic determines which manual functions can be activated at any point in the wrapping cycle. Should the operator incorrectly select a function at a certain stage during the wrapping cycle, then that operation will not be performed.

2.5 Hand held Controller

The hand held controller manually operate the Load arm Up/Down and Squeeze In/Out in **N** (NORMAL) function. In **S** (second function) it operates the Conveyor Up/Down and In/ Out. The active function is shown on the left of the controller display, See below. Pressing the **ESC** button toggles between **N** and **S**.

The machine is folded into the road transport position and unfolded to the working position with the hand held controller. See section 10.9 for further information on this.

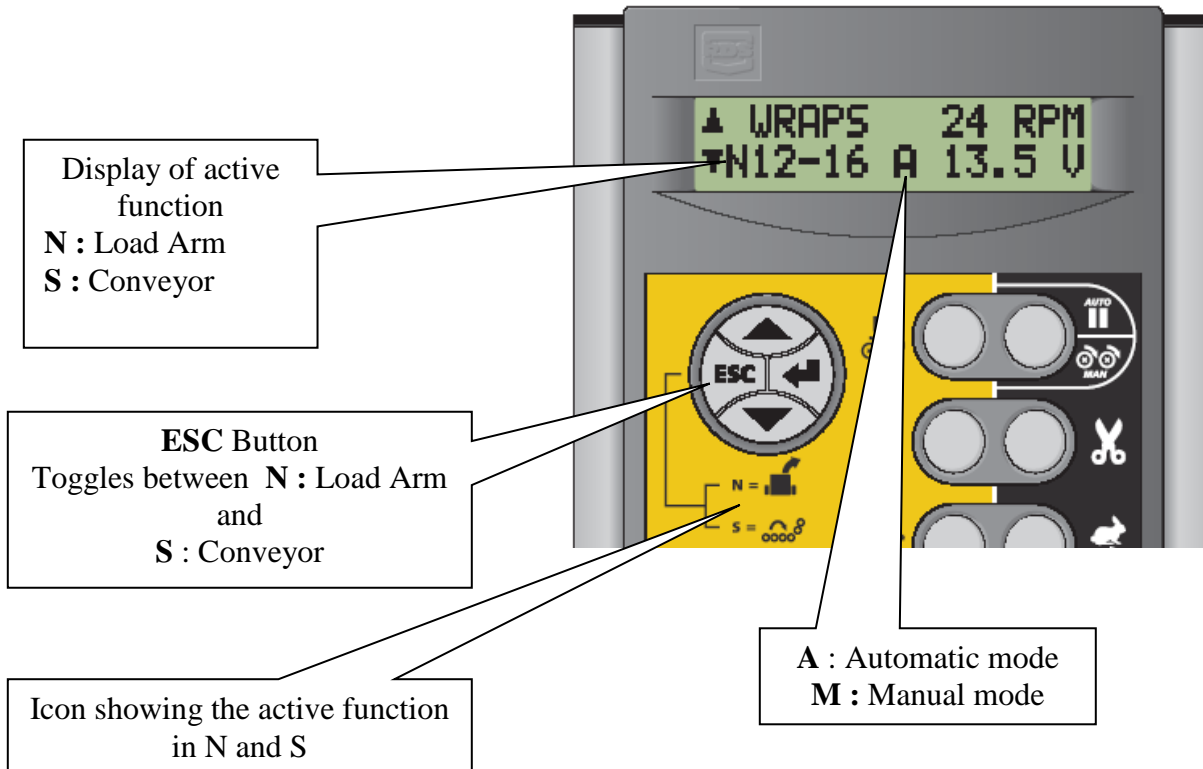
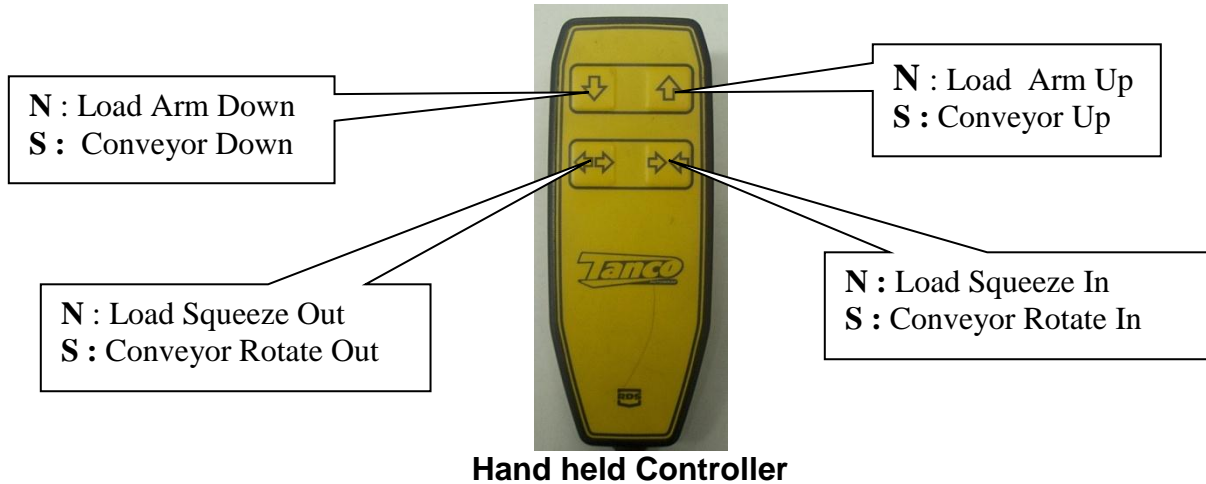

2.6 Radio Frequency Remote Controller



The Radio Frequency Remote control is fitted as standard on the static ARC and S Models, it is available as an option on the LA Model.

The remote control facility allows the Wrapper to be entirely controlled from the cab of the loader tractor. The Wrapper is usually parked near where the bales are to be stacked.

Note: The red safety button on the back of the hand held sender unit must be pressed with a button on the front to activate any function other than STOP.

The Wrapper controller must first be set for the desired number of wraps and must be put into the A (Auto) standby mode. (see section 7.2.10)
Then pressing AUTO START button will start an automatic wrapping cycle.

Pressing STOP will instantly stop the wrapping cycle.

From the remote it is also possible to:

1. Manually rotate the wrap arm forward and reverse.
2. Open and close the film Cut and Starts.
3. Add extra wraps to the present bale. (see +1 in section 7.2.3)
4. Manually offload the bale (Tip). This button will also solve the BALE NOT LEVEL error message (see section 10.8) by manually rotating the bale for offloading.

*Note: If a new remote control sender unit is being fitted, the controller must be set to receive the unique frequency of this sender. Go to Remote Type in the Operator Setup on the controller, then, enter to RF Learn. Press the Auto Start (and safety button on the back) on the remote sender. A number should flash up on the screen to indicate the controller has picked up and registered the frequency. The new unit is now ready for operation.

2.7 The Display Menu

The menu is divided in 3 sections. At the top level the settings used during the daily work with the machine – i.e. Store totals and No. of Wraps.

The Operator Setup' section enables the operator to perform adjustments to the machine operation – e.g. time duration and time delay settings during the automatic cycle.

The 'Technician Setup' menu is not normally accessible to the operator without a PIN access code. 'Technician Setup' is not covered by this manual.

Use the 4-way switch to navigate the menu. Each menu screen indicates which keys to press to make the settings. The instrument will default back to the main operating display after 30 seconds if no other key is pressed

Here is a summary of the display menu;

Controller Menu Structure

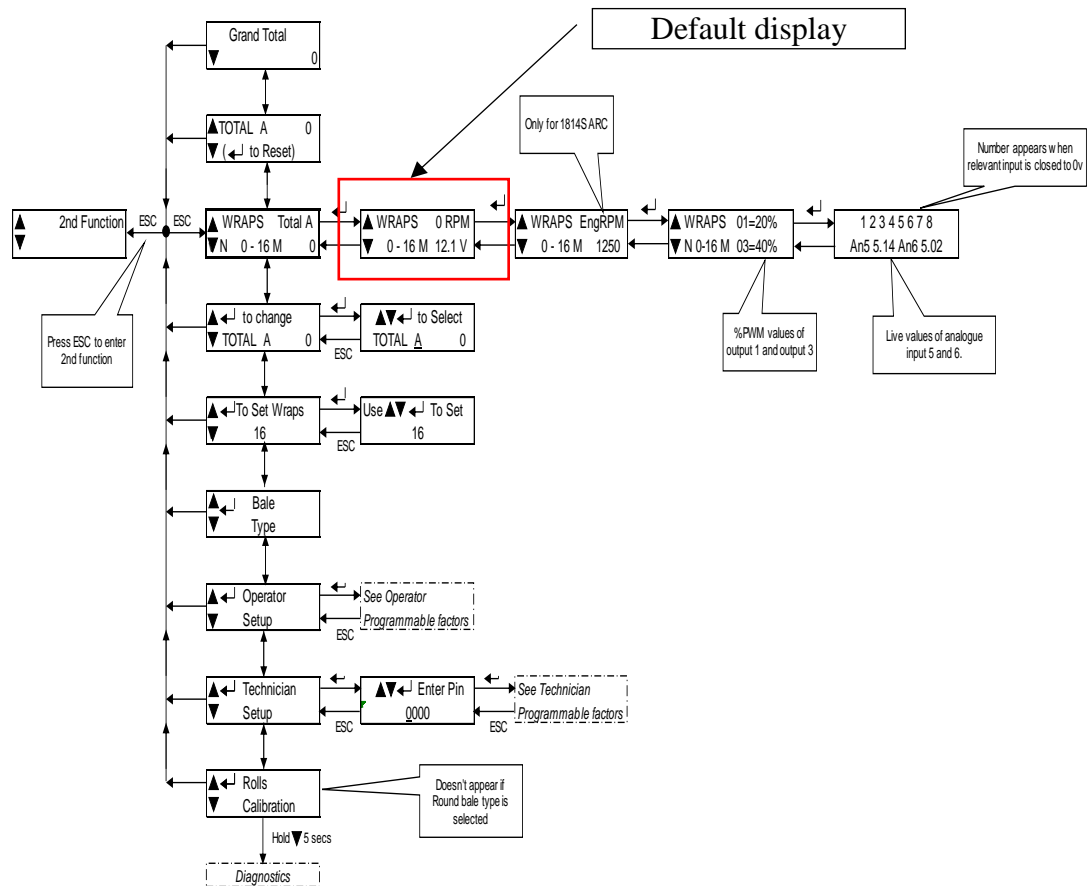



2.8 Selecting a Store Total

There are 10 individual memory registers labelled 'Store A' to 'Store J' for bale totals. Each time a bale cycle is completed, the currently selected store total and the grand total increments by 1.

The currently selected store is displayed on one of the two screens selectable in the normal operating mode.

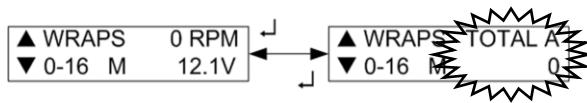

The default setting is Store A. To select a particular store, navigate the display menu using the 4-way switch.

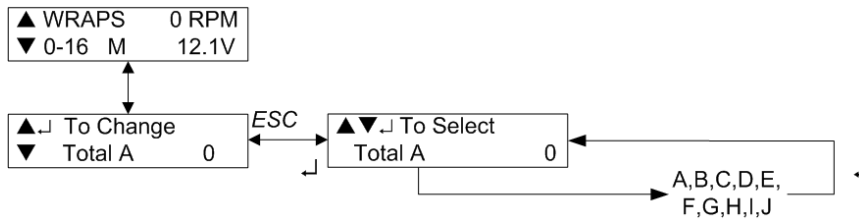

Press the up/down arrow keys to select the store, then press the ENTER key to confirm the selection.

2.9 Resetting a Store Total to Zero

Stores A to J can be individually reset to zero at any time. The Grand Total store cannot be reset. First select the store to be zeroed, then navigate the display menu as shown below.

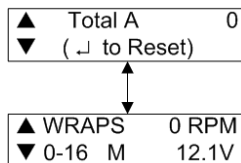

Press the ENTER key to reset.

2.10 Setting the Number of Wraps

The default number of wraps is 16. You can set the target number from 0 to 99 by navigating the display menu as shown below.

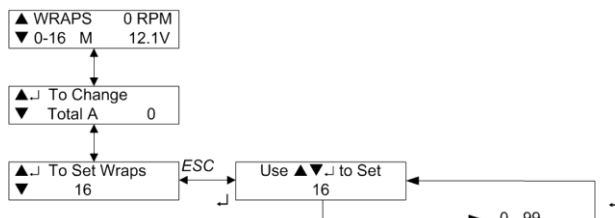



3 Bale type Setup Menu

The 1814 is fitted with sensors on the rocking rollers to sense the angular position of the bale. This information is used by the controller to optimize film application on rectangular bales. The rotational speed of the bale is automatically changed during wrapping to ensure that we have a consistent overlap (see section 9). It is also used to rotate the bale to a level position for off-loading.

Bale Type Default Settings

Factor	Round	80x90 (square)	120x70 (rectangular)	120x90 (rectangular)	47x80 500 (rectangular)	47x80 TWIN (square)
-	-	-	-	-	-	-
Rolls slow speed	NA	NA	32%	35%	28	NA
Rolls fast speed	41%	40%	41%	41%	38	41
Stop Bale Pulse	1	1	1	1	1	3

ROLLS CALIBRATION:

To set it up, you must place a bale on the turntable. Then press and hold the top right button (rolls rotate) and allow the bale to do a full rotation. Go to the Rolls calibration menu and press enter. Again press the right button (rolls rotate) and allow the bale to do a full rotation. This records the max and min values for each sensor during a rotation. The values are displayed. If they are satisfactory you must press enter to store them.

Note: If you do not do a rolls calibration for the particular bale size initially then the proportional control of the rocking rollers during wrapping will not function. Once the values have been saved they remain with that bale size. i.e no need to recalibrate it.

IMPORTANT: The default values have been selected as being the optimum for a certain bale size but note that variations can occur with the particular valves on a machine so it may be necessary to tweak them a bit. Please consult with your dealer if you are unhappy or unsure about the overlap on the bale.



4 Operator Setup Menu

The default settings for the machine are developed by Tanco for optimal operation of the machine. However, the operator can change certain parameters in the 'Operator Setup' menu to take account of operational conditions.

1814 Operator Setup

Software rev. 049

Parameter	Default	Menu no	Description
Contrast	FULL	4.01	Adjusts the display contrast
Film Break	OFF	4.02	Set 'ON' to enable sensors on the film dispenser. This allows you to continue wrapping with only one dispenser when one runs out.
Remote type	IR	4.41	Set to RF if you using Radio remote.
Continuous	Off	4.55	Set Off the controller will run Loading, Wrapping and Offloading as individual functions and stop when each is complete. Set 'ON' the controller will run a complete continuous cycle, Loading, Wrapping and Unloading with just one button press, L5 button.
Squeeze in	0.0s	4.07	Set time period squeezing during auto load sequence
Load up +	0.0s	4.08	Set load arm up time period past up sensor in auto load sequence
Squeeze out	0.0s	4.09	Set time period grab open during auto load sequence
Load down pause	0.0s	4.1	Set time period between grab open and load down during auto load sequence
Load Down +	0.5s	4.53	Set load arm down time period past down sensor in auto load sequence
Load up delay	0.0s	4.54	Time period between squeeze and load arm up in auto load sequence.
Conveyor Down	0	4.14	If required you can set the conveyor to be slightly raised while wrapping (by adjusting the conveyor down sensor posn). This sets the time period that it drops for during auto unload sequence
Pre-Rotate	0.0s	4.51	Time period which the bale rotates on the table before wrapping so on rectangular bales the film is applied to the long sides of the bale first.
Stop bale pulse	1	4.22	Select the no of ½ turns of the wrap arm before the bale starts turning at the start of the wrap sequence.
Wraps to release	2 Pulses	4.23	Selects the no of wraps before it film is released by the Cut and start units
Release 2	10 Pulses	4.24	Selects the no of wraps before the second film release by the Cut and start units
Delay To Stop	0.0s	4.27	Selects the delay on the last rev before wrap stops (note: it will always reverse back till it sees the sensor)
Bale Unload	8	4.29	The time period the rollers turn to unload the bale from the Rocking rollers to the unload conveyor
Conv. Level	No	4.57	Set to No, the conveyor remains in the down for unloading. Set to Yes, the conveyor raises to receive the unloading bale.
Language	English	4.35	Select the display language.



5. Technician Setup Menu

1814 Technician Setup (Pin 1,2,3,4)

Software rev.050

Parameter	Default	Menu no	Description
Sequence	1814	5.01	Sets controller to machine model. Should be 1814 or 1814S ARC
Slow Arm PWM	25% *	5.39	Sets Wrapping Arm slow speed by setting min. % valve opens. Note: not actual RPM
Fast Arm PWM	40% *	5.4	Sets Wrapping Arm fast speed by setting max. % valve opens. Note: not actual RPM
Rev Arm PWM	23% *	5.41	Sets Wrapping Arm speed in reverse direction
1 -D Fast Speed	38%	5.51	Sets Wrapping Arm fast speed when wrapping with one roll of film
Rolls Slow Speed	32% *	5.45	Sets Bale Rollers slow rotation speed (on rectangular profile bales)
Rolls Fast Speed	41%	5.42	Sets Bale Rollers fast rotation speed (on rectangular bales)
1-D Rolls Speed	30%	5.47	Sets Bale Rollers rotation speed when wrapping with one roll of film
Bale level at	25%	5.52	Sets the tolerance between the angular position of both rocking roller set that the controller considers the bale is sitting level on the table. This can be increased if there is a problem levelling the bale.
Rolls Ramp	0.1 Secs	5.46	Set time period for Bale Roller speed to change speed.
Slow Start Time	3.0 Secs	5.15	Time period Wrapping Arm rotates in slow speed at the beginning of wrapping cycle.
C&S Open Time	0.3 Secs	5.16	Time period Film Cut and Start opens during wrapping to release hold on film.
C&S Close Time 1	0.3 Secs	5.17	Time period Cut and Start closes during wrapping after releasing hold on film
C&S Close Time 2	2.0 Secs	5.18	Time period Cut and Start closes at the end of wrapping cycle to cut and hold the film.
Level timeout	5.0 Secs	5.54	Maximum time period the bale is rotated to get it into a level position for offloading. The rotation will stop before this time if the feedback from the rocking roller angular sensors say the bale is level
Rolls switch %	65%	5.55	Sets the point in the rotation of the bale where the roller speed changes from fast to slow.
Rolls slow min	0.5 Secs	5.56	Sets the minimum time the rollers stay in slow speed
Release Delay	0.0 Sec	4.25	Sets the point during the revolution of the Wrapping Arm that the Cut and Start opens to release its hold on the film.
Del. to C&S Open	0.3 Secs	4.44	Sets the point during the last revolution of the Wrapping Arm that the Cut and Start opens to cut and hold the film
Delay To Slow	0.4 Secs	4.26	Sets the time period the Wrapping Arm stays in fast speed during the last revolution of the wrapping cycle.
Conveyors Delay	2.0 Secs	5.38	Sets the time period between the bale off-loading from the table to the conveyor and the Conveyor rotating to discharge the bale.
Hyd Type	Open Ctr.	5.6	Not applicable, leave set to default of Open Ctr.
Auto Hand Cont.	Off	5.59	Should be left set to default Off
RPM Alarm	35 RPM	5.25	Sets maximum Wrapping Arm speed above which an alarm will sound and the wrap arm will stop.
Set Default		5.28	Resets the controller to default valves.



8. WRAPPING ARM SPEED SETTING.

Load a bale on to the machine. The wrap arm speed should be factory set to about 27 rpm. It can be adjusted by altering the **Fast Arm PWM** in the Technician Menu. Ideally this should be done by an experienced technician. If the tractor hydraulic output is less than the 50lt/min recommended it may be necessary adjust the flow control valve which divides the flow in the main valve. (see Hydraulic circuit). When the wrapping arm speed is OK, you can set the overlap.

9. FILM OVERLAPPING SETTING.

Commence a wrap cycle and stop it after a few turns of the wrap by pressing the red button. Check that the plastic coming off the dispenser is meeting the plastic already on the bale in a position where more than half the film is overlapping the plastic already on the bale. It is always important to check this with the long side of the bale standing up as this traditionally the side that get least plastic due to the geometric condition with rectangular bales. Approx. 52-53% is the ideal overlap.

The overlap is set in the Technician Setup on the controller. It is important to select the right bale size and check the overlap whenever you start a new bale size. When wrapping rectangular bales the controller varies the indexing speed of the bale, it rotates slowly when the bale is standing tall and faster when the bale sitting low. In the Technician Setup, the fast roller speed is adjusted by altering the **Rolls Fast Speed** and similarly the **Rolls Slow Speed** for slow. These changes are best left to an experienced technician.

IMPORTANT: If you have less than 50% overlap, what happens is that while most of the bale will have 4 or 6 layers, some narrow strips will have half that.

Therefore **DAMAGE TO SILAGE!**

Tanco do not accept liability for any damage to silage as they cannot supervise the wrapping and storage of your bales. It is the responsibility of the operator of the machine to check this.

10.0 OPERATING INSTRUCTIONS.

We shall now go through a complete wrapping process, from loading to unloading, and explain the practical use of Tanco 1814.





10.1 Fitting a roll of film.

See Section 6.0

10.2 LOADING (LA Model only)

For the first bale, ensure that the rollers are set the correct width for the bale size (See Section 10.3). The dispensers should be in the park position close to the film cut & start. Ensuring you have enough room around the machine, lower the conveyors (remove parking bracket first) and lower the load arm.

Note: that the machine overhangs on both sides the tractor when it is folded out. This requires care from the operator not to damage other bales or objects in the field.

With the Controller in N mode, Drive into the bale and squeeze it by pressing  button on the hand-controller. Then press  to raise the load arm close to the rocking rollers. Release the bale by pressing . Then lower the load arm to again by pressing .

This sequence can be done automatically by pressing  if the controller is configured to operate in this way see section 7.0. However this may not be suitable the oil flow from the tractor varies.

10.3 Setting up the rocking rollers

The width between the rocking rollers can be adjusted by changing the position of the width stop pins and moving in and out the Left hand rocking roller frame. This is done on a separate service using the tractors spool valve. For smaller bale move rocking rollers closer together and for larger ones move them apart. (See Fig 10.3).

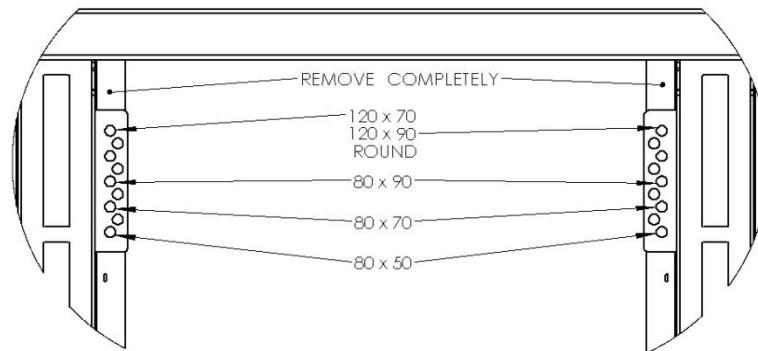

Fig. 10.3 Recommended rocking roller width positions.

There are also rocking roller stops mounted on the rocking roller frames. These limit the drop of the rocking roller frames and do not need to be adjusted in general.

Warning There a risk of crushing fingers and limbs when adjusting the rocking rollers! See Section 2.4

The Bale should rotate smoothly; no ‘tumbling’ should be evident. If this occurs adjust one of the roller sets out one hole at a time. The rollers should always run parallel to one another.

10.4 HEIGHT ADJUSTMENT OF FILM DISPENSER.

The Dispenser has to be adjusted so that the plastic film is always hitting the Centre of the bale. Therefore it is recommended to keep the film dispensers as low as possible and to keep the bale as high as possible (rocking roller width is minimum).

10.5 START.

Remember that the plastic film end has to be held in the Cut and start unit or attached to the bale before starting the wrapping cycle. When the tail of the film is held in the cut and start, press the  button to start the wrapping cycle in



automatic mode. Note as part of the wrap sequence the film will be released automatically after 2 revolutions and again after 5.

10.6 OVERLAP.

There should be a film overlap of 50% - 53%. (for adjustment see Section 9) This should be checked frequently as changes in hydraulic oil temperature could result in the overlap increasing or decreasing.

10.7 HOW MANY LAYERS OF PLASTIC FILM?

Depending on the moisture content and the type of bale being wrapped the typical minimum no of layers required are;

- * **4 layers – round bales**
- * **6 layers – Square bales.**
- * Follow your plastic manufactures guide on the film layers required

Using a 50% overlap (see section 10.6) cover the bale completely in film, then rotate the wrapping arm around the bale 1 more time. This number should be an even number (typically 4 rotations for a 1.2m round bale). If a small square of plastic was removed from the side of the bale, 2 layers should be found. Note the total number of revolutions on the controller (see section 2.5) and then multiply it by 2 for 4 layers, 3 for 6 layers etc.

10.8 STOP.

At the end of the wrapping sequence, before the required number of revolutions is obtained, the speed of the wrapping arm is reduced the cut and start units open to catch and cut the film and the arms go back to the park position, the wrapping arm is then stopped. Rectangular bales are now rotated to a level position for offloading. If the bale does not level automatically, the controller will give an error message **Bale Not Level** see section 2.3 for solution. The bale is then offloaded onto the discharge conveyor. At this stage it is now possible to load the next bale if desired.

10.9 Unloading.

When you are in a suitable position to discharge the bale, press the  button in automatic mode commences the unload sequence. There should be sufficient space for the conveyor to rotate and ground conditions should also be suitable . A smooth flat area without stones or other sharp objects is necessary. Note also that some grasses have tough stubble which can cause damage to the bales during unloading. Check this with great care. Also ensure that you have adequate room operate.

10.10 Transport/Working position. (LA Model only)

To fold the machine for road transport:

With hand controller in N (load arm setting see section 2.5)

Close squeeze fully using had controller

Change N to S (press **ESC** button)

Raise conveyor fully

Change N back to S, (**ESC**)

Raise load arm fully

Fit parking bracket on conveyor, see fig 2.7.

To unfold the machine for operation, reverse the above procedure.



10.11 Continuous Operation (LA Model Only)

To maximize the output of the 1814 machine it should be operated in **Continuous** mode. This can be set on or off in the **Operator Setup** on the controller. When **Continuous** is **On**, the machine loads a new bale and discharges the wrapped bale simultaneously and wrapping commences immediately the load arm is down. This reduces cycle time so increasing output. Note in Continuous mode the machine has operations happening on both sides so take care that it is safe to do so.

10.12 Pre load. (LA Model only)

It is possible while a bale is being wrapped to squeeze and raise the next bale clear of the ground and move to where the wrapped bale is to be discharged.

This pre loading can be done manually with the hand held controller (see section

2.5) or automatically by pressing  during wrapping. This will squeeze and raise the bale in one operation. The loading will stop at a height where the wrapping arm can pass over new bale. When wrapping has finished and the wrapped bale has been

moved to the off load conveyor, pressing  will load the new bale on the table and discharge the wrapped bale to the ground.



11.0 PERIODIC MAINTENANCE.

11.1 BEARINGS.

All pivot points are fitted with bushes and require regular greasing. Particularly those which are regularly articulating such as all pivot points are the load arm, rocking rollers, discharge conveyor and cut and starts. These should be greased daily. The ball-bearings on the rocking rollers and the dispensers are packed with grease, and do not need any more maintenance. See Figure 11.1.

11.2 FILM DISPENSER.

If the machine is in daily use, the Gears under the plastic cover on the dispenser should be greased when needed.

11.3 CUTTER / FILM HOLDER.

The cutter / film holder is pre-adjusted from the factory and does not need further adjustments. When replacing spare parts, it is necessary to adjust it. The springs for the U-shaped slot shall be adjusted so that there is 8 - 10mm of bolt exposed below the plate.

11.4 CLEANING.

The machine should be cleaned and oiled regularly during and at the end of the wrapping season.

NOTE !

When using high pressure washing apparatus, care must be taken with the electrical installation.

Also make sure that water is not sprayed directly into the bearings, etc..

Keep the control box protected from rain and water. If necessary use compressed air to dry electrical components.



11.5 HYDRAULIC CYLINDERS.

Make sure that all hydraulic cylinders are closed or the exposed cylinder rod is covered in grease when storing the machine.

11.6 QUICK COUPLERS.

Ensure that the quick couplers are kept clean and apply the dust caps after use.

11.7 STORAGE.

The machine should be parked on a dry place during the closed season.

11.8 OIL FILTER.

The oil filter must be changed once a year.

12.0 ELECTRIC CIRCUIT DIAGRAM 1814

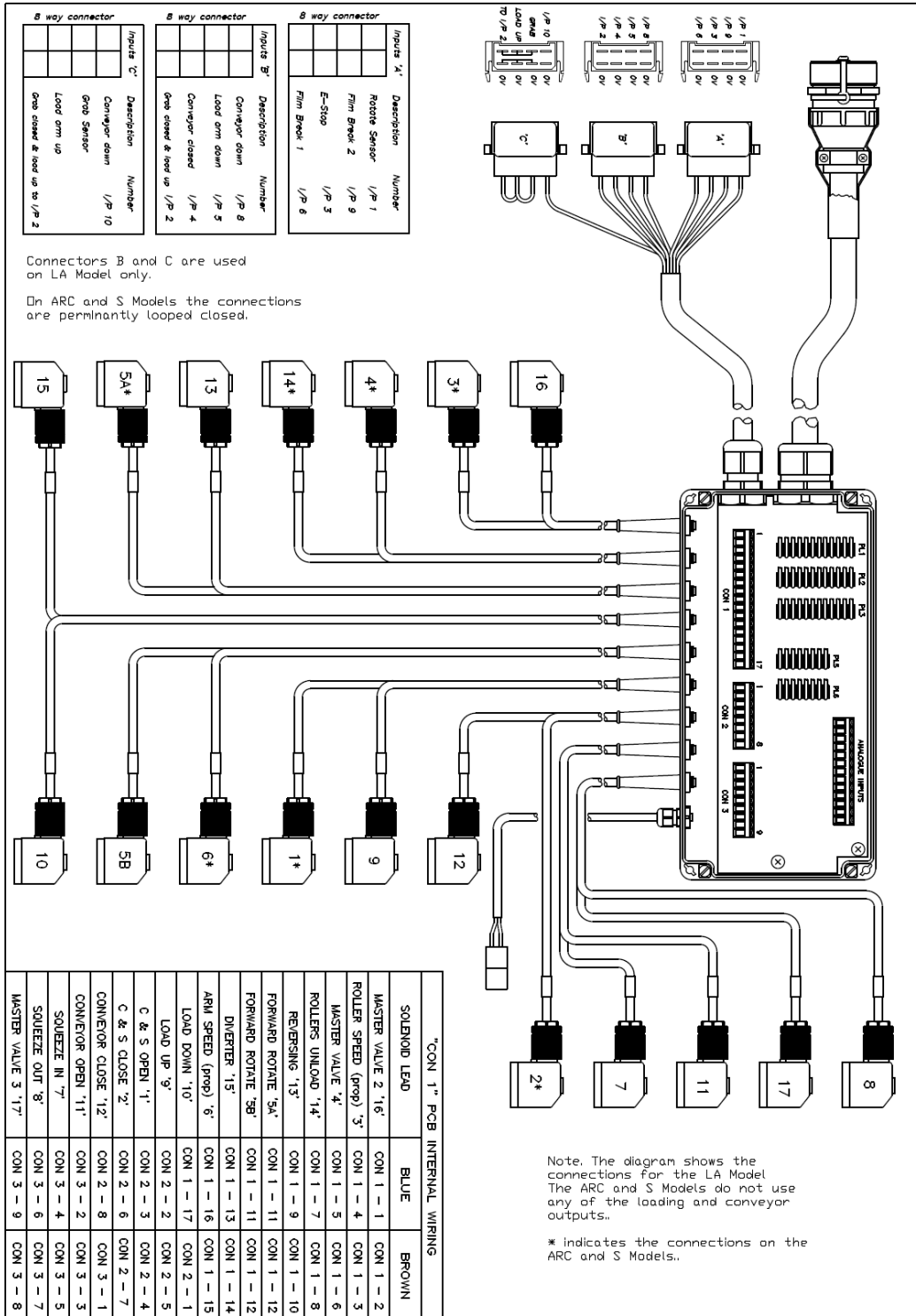

12.1 Sensor Connection Diagram 1814

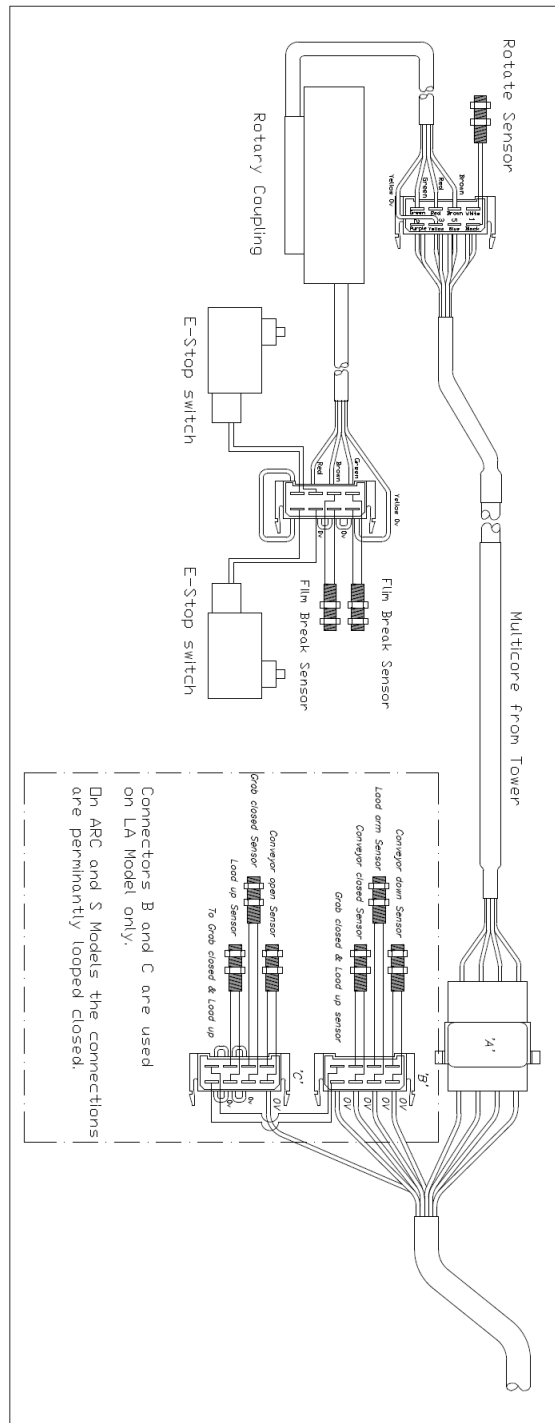

12.2 Sensor Location Diagram 1814

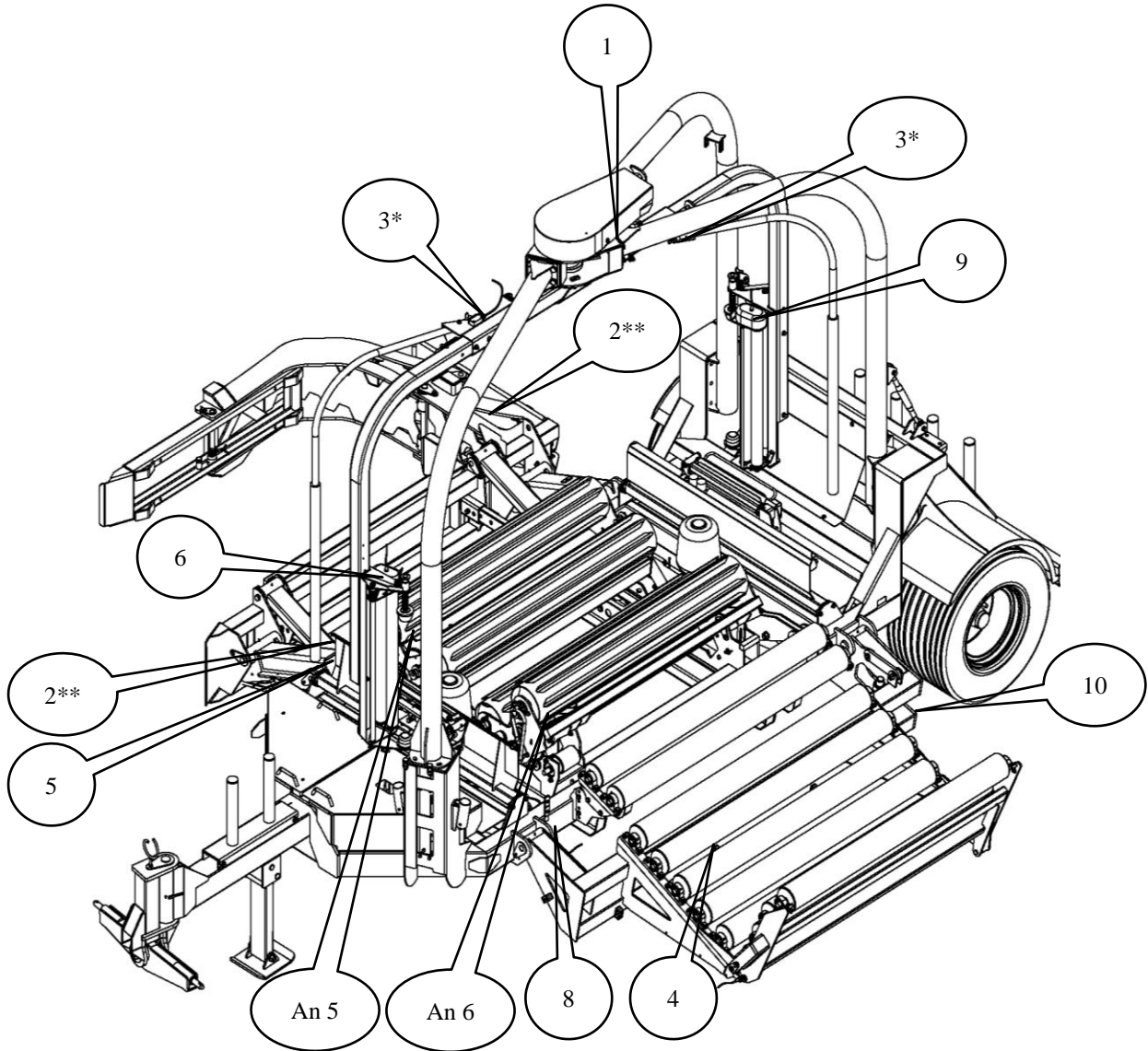

* The two Safety Arm Switches are connected to one Input (3).

** The Load Arm Sensor UP and Grab Sensor are connected to one Input (2)

The Grab Sensor is only required for safety when folding the machine into and out of the transport position.



1814 Wiring Details

Tanco Solenoid	Generic Function	Cable Number	AMP Pin	1814 Function	1400 Function
1	OP6	18	24	C&S Open	C&S Open
2	OP7	15	6	C&S Close	C&S Close
3	OP1	14	7	Roller Speed (prop)	Roller Speed
4	OP2	3	14	Master Valve	Master Valve
5A	OP4	31	16	Forward Rotate A	Forward Rotate
5B				Forward Rotate B	
6	OP3	6	18	Arm Speed (prop)	Arm Speed (prop)
7	OP13	30	10	Squeeze In	Squeeze In
8	OP14	11	15	Squeeze Out	Drawbar Out
9	OP8	24	22	Load Up	Load Arm Up
10	OP9	27	2	Load Down	Squeeze Out
11	OP16	1	19	Conveyor Open	Tip Off
12	OP15	5	12	Conveyor Close	Tip Return
13	OP11	16	11	Reversing	Reversing
14	OP10	26	3	Rollers Unload	Drawbar In
15	OP5	4	13	Diverter	Load Arm Down
16	OP12	25	4	Master Valve2	12 volts
17				Master Valve3	Not Used
	IP1	12	9	Rotate Sensor	Rotate Sensor
	IP2	2	20	Grab Sensor	Not Used
	IP3	20	31	Emergency Stop	Emergency Stop
	IP4	19	30	Conveyor Closed	Not Used
	IP5	22	33	Load Arm Down	Squeeze Out
	IP6	13	8	Film Break 1	Film Break 1
	IP8	29	5	Conveyor Position	Not Used
	IP9	28	1	Film Break 2	Film Break 2
	IP10	17	17	Conveyor Open	Not Used
	AnIP5	8	26	Right Roller Position	Not Used
AnIP6	7	25	Left Roller Position	Not Used	
AnIP7	32	29	Not Used	Not Used	
0v	35	35	Common 0v		
0v	34	34	Common 0v		
0v	33	23	Common 0v		
0v	9	27	Common 0v		
0v	10	21	Common 0v		
An0v	21	32	0v (Analogue)		
5v Supply	23	28	5v Supply (Analogue Inputs)		

There are 3 basics, which must **ALWAYS** be followed if the machine is to function correctly

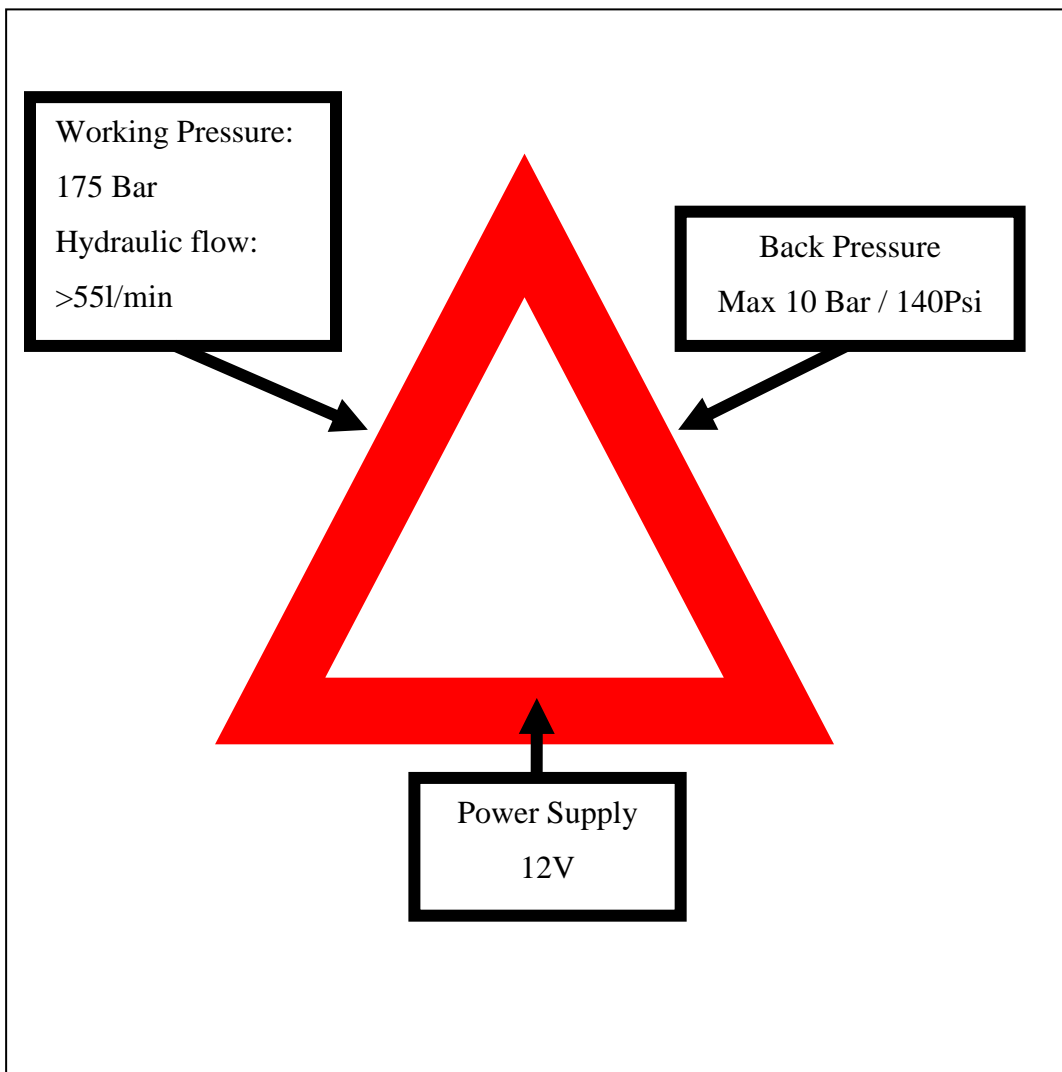

13.0 DESCRIPTION OF HYDRAULICS.

LA Model

The 1814LA Model can operate on tractors with Open or Closed Centre or Load Sensing hydraulics.

Control Valve

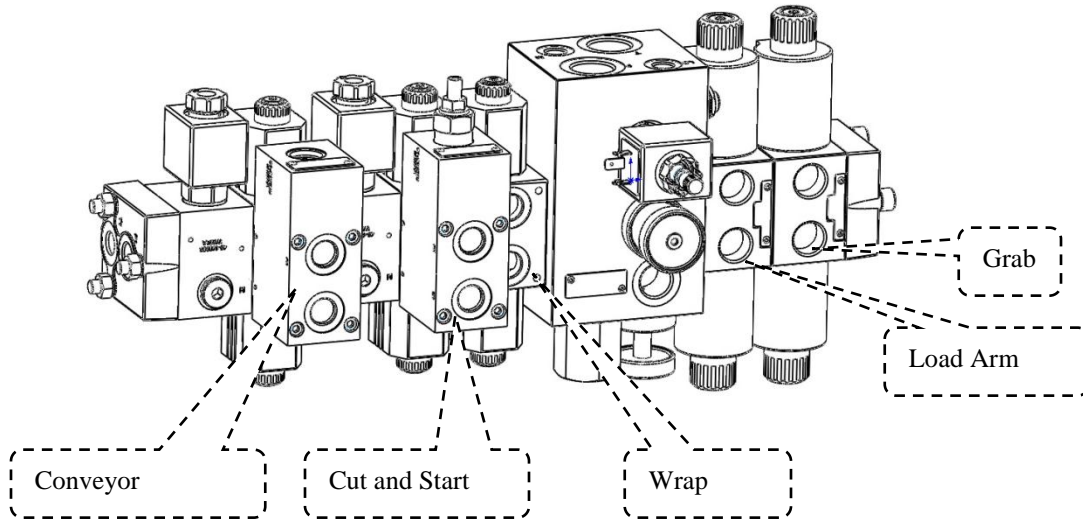

13.1 SETTING FOR TRACTORS HYDRAULIC SYSTEM.

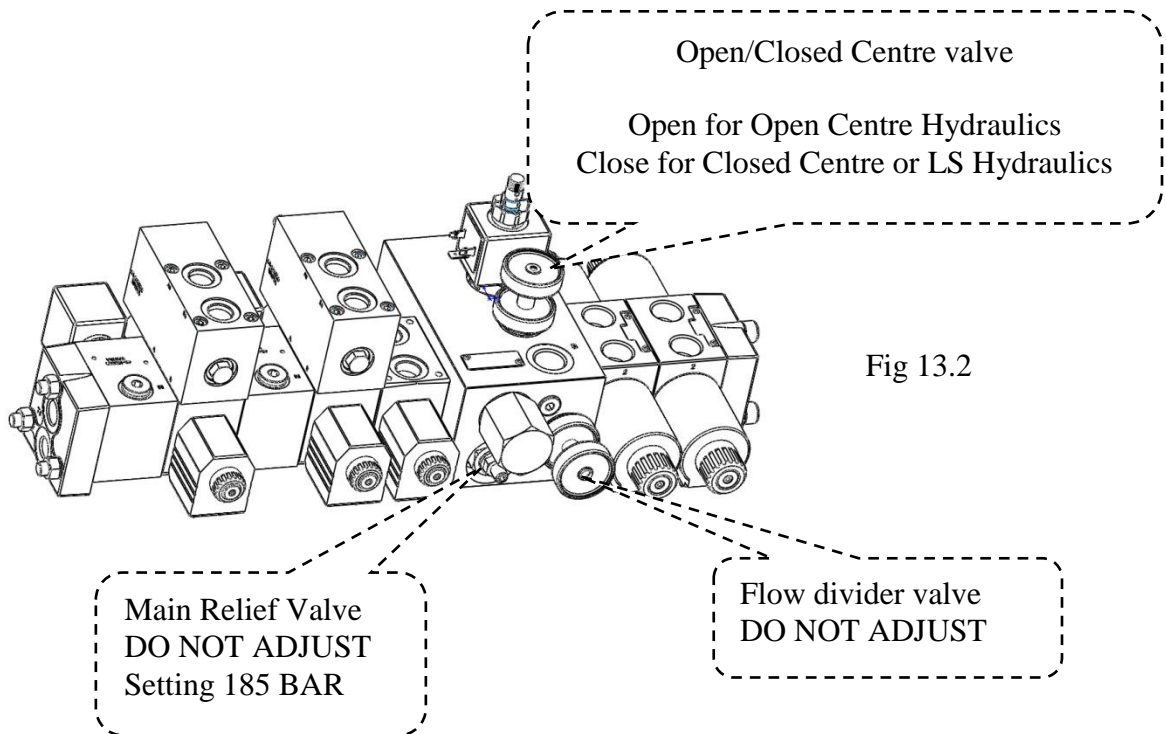

Fig 13.2

Open Center Hydraulics

Most tractors have an “Open Centre” Hydraulic System which delivers a continuous oil supply. The 1814 machine is set as standard to suit this. The Open/Closed Centre valve is fully opened. See fig. 13.2.

Closed Centre Hydraulics

A tractor with a “Closed Centre” hydraulic system requires the machine to block the oil supply through the machine when no function is operating. This is done by fully closing the Open/Closed center valve. See fig 13.2.

Load Sensing Hydraulics.

Many modern tractors have a “Load Sensing” (LS) hydraulic system. This is most efficient as the pump remains on standby, pumping no oil until it gets a signal from the machine. This LS signal is sent to the tractor by a third (small) hydraulic hose. For LS operation the Open/Closed valve is fully closed and the LS signal pipe is connected to the LS port on the tractor.

ARC Model

The ARC Model can be changed from open centre to closed centre by locking the master valve on the control valve closed. Push in and twist the knurled knob to lock it closed. See fig. 13.3

The control valve is located behind the cover on the back bulkhead on the machine.

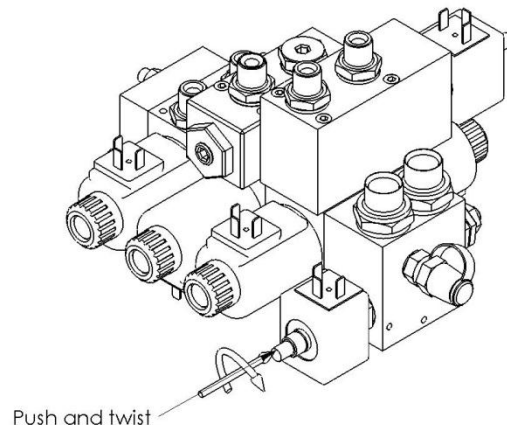

Fig 13.3

13.2 Hydraulic valves on front of chassis (LA Model ONLY)

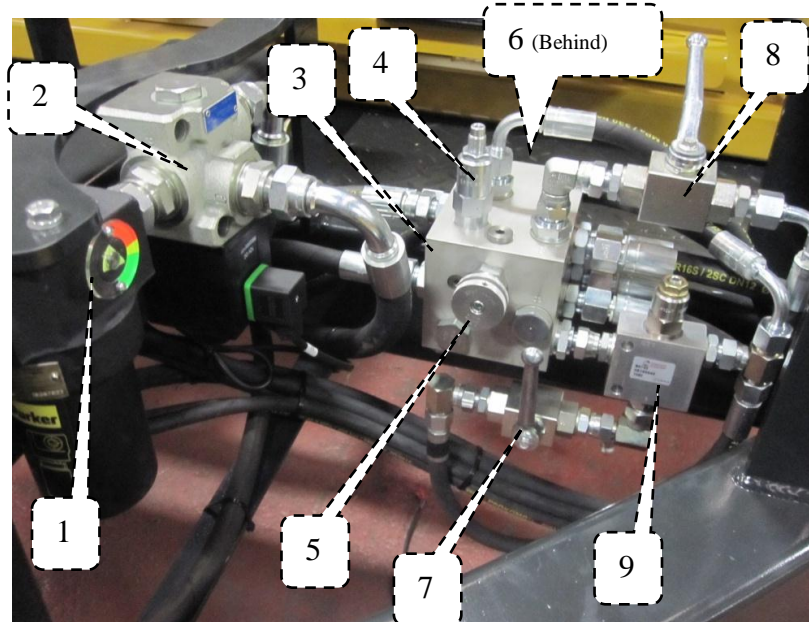

Fig 13.4

1. Oil Filter. Indicator shows filter condition when oil is flowing.
2. Master valve. This valve is energized with every function on the machine
3. Assembly block.
4. Sequence valve for leveling rocking rollers before off-loading bale. This is factory set fully out and then in two turns. For tipping rocking roller with optional round bale kit fitted, this valve must be screwed in at least 1 more turn. This is to give the tipping hydraulic cylinder sufficient pressure to tip.
5. Manual shut off valve. Open this if you want to relieve the pressure on the roller leveling cylinders. Must be closed during wrapping or the unloading sequence won't work (Rollers will not rotate!)
6. Over-center valve, this stops rectangular bales toppling while wrapping. Screw in fully and then out one and a half turns. If this is set too high the operating pressure during wrapping will be increased.
7. Shut off tap to leveling cylinder. Close this with the rollers down (See 5 above) for wrapping round bales. This holds the rollers in the down position. (Valve in picture in closed position)
8. Shut off tap for Tipping rocking rollers. Close this if you do not want the rocking rollers to tip (if optional tipping kit is fitted).
9. Rollers leveling holding valve. This valve holds the rollers level for loading.

13.3 WRAPPING ARM VALVE BLOCK.

The wrapping arm valve block is mounted inside the cover on the back bulkhead of the machine. It holds 5 valves.

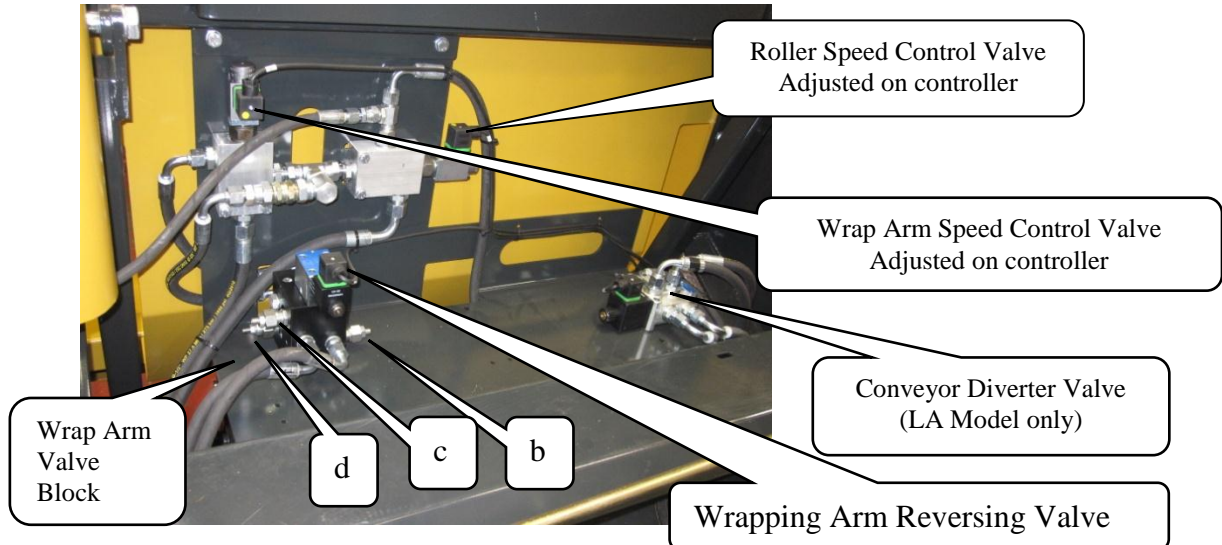

Fig 13.5

a) Non return valve.

The non-return valve is mounted internally in the block, inside the P port. It stops the wrap from reversing when parked.

b) Safety valve on the plus side.

This cross line relief valve reduces the shock loading on the wrap arm drive motor when it stops suddenly.

c) Safety valve on the minus side.

This cross line relief valve limits the max. torque of the wrapping arm drive motor. It is adjusted so that the pull force on the end of the arm is approx. 50 KG.

d) Holding valve.

This holding valve stops the wrap arm rotating forward when parked. It also maintains a positive pressure on the motor outlet, this makes the wrap arm run smoother.

e) Wrap Arm Reversing Valve

This valve reverses the rotation direction of the wrapping arm.

IMPORTANT: All these valves have been carefully set in the factory. Incorrect adjustment of these may cause damage to the machine. Always ensure that trained personnel only adjust the settings.



14.0 CHECK POINTS BEFORE TROUBLE SHOOTING.

In this chapter we have some general check points that have to be examined first if something is wrong with the machine. In chapter 17.0 we have a more detailed trouble shooting.

There are three basic assumptions that have to be fulfilled if the machine shall function properly:

1. The oil pressure from the tractor should be 180 bar.
2. The return flow of oil has to be as free as possible, **max. 10 bar counter pressure.**
3. Enough electric power to all functions.

14.1 OIL PRESSURE.

In order to check that the oil pressure into the machine is high enough, a gauge may be connected using the test pressure points on the both main valve blocks. When no function is operating the pressure will be the return line pressure. If the pressure is less than 150 bar, there will be less power for the functions. The build up the pressure manually close the master valve or select and hold a function on e.g. CUT& START CLOSE.

OIL FLOW.

The minimum oil flow for the LA Model is **50 liters/minute**, but it is recommended that it is 60 liters/minute and max. of 70.

30 liters / minute is the recommended oil flow for the 1814 ARC Model.

REMEMBER! Large oil amount = Valves get hot. (Small oil tank = insufficient cooling).

14.2 RETURN PRESSURE.

The return pressure can be too high. With high return pressure the machine's functions will get less power. High return pressure means also that you need more power to operate the valves.

MAX. ALLOWED RETURN PRESSURE IS 10 BAR.



We recommend "free return" directly to the tank.

14.3 ELECTRIC POWER.

It is important to check that all functions receive enough electric power. If not, some, or all functions may fail.

Is the battery voltage high enough?

If the voltage falls below 9 volts the valves will not be able to open.

Are the cables correctly connected to the battery?

Follow directions in chapter 4.4

Is the connection between battery cable and control unit OK?

Clean off the poles and check the plug.

Is the connection between remote control unit and machine OK?

Change contacts if any doubt about the condition.

Is the fuse on the battery cable OK?

PLEASE CONTACT YOUR DEALER IF YOU ARE IN DOUBT ABOUT ANYTHING.

(Remember, always to give your dealer the serial number and production year of your machine when contacting them dealer and ordering spare parts).

15.0 PROCEDURE OF TROUBLE SHOOTING.

15.1 SOLENOID VALVES.

When checking if the Solenoid valves are receiving electric power, you do this in the following way with the tractor stopped:

1. Unscrew the nut that holds the solenoid.
2. The solenoid is easy to move without electric power.
3. Push the current function on the remote control. If the solenoid gets power, it will be difficult to move, it "sticks". This is the best and easiest way to check if the solenoid valve is receiving electric power. Another way is to hold a screwdriver up to the magnet. If it "sticks", the solenoid is receiving electric power.

The power supply to the valve can also be measured with a voltmeter, but then the contact must be connected to the solenoid, so it is using power.

To have reliable functions, the voltage should not be lower than 11,5 volts, even if the solenoid valve usually works with a little lower voltage.

15.2 Only for solenoid valves to the main functions.

If the electric supply is in order and one of the functions fails, the reason can be dirt that tightens or prevents the sliding shaft (spool) from moving.

Try to maneuver the function manually, by pressing the point of a screwdriver into the end of the valve housing. **At the same time the corresponding switch on the control unit has to be operated to get electric power to the master valve.** If the function is working again after this, the dirt may have been pushed out in the oil system and the machine can be operated normally again.



Take care so that the machines moving parts, do not cause damage to persons or objects.



16.0 TROUBLE SHOOTING.

16.1 THE MACHINE DOES NOT FUNCTION.

- a) Even if the gauge shows enough pressure and there is no reaction in the machine. The reason could be that one, (or both), of the quick-couplers does not open for the oil.

Change quick couplers.

- b) The counter pressure could be too high.
Max. allowed counter pressure is 10 bar. (See chapter 14).

- c) Make sure that the master valves are functioning. These can be manually closed. Check that the pressure builds when either are closed. You will hear the tractor labour.

(Disturbances of this type, a, b or c, are most likely in the first days that the machine is in use).

16.3 THE CUTTER WILL NOT HOLD THE FILM.

The pressure is falling and the springs start to lift the cutter. (See chapter 14.2).

16.4 THE WRAPPING ARM WILL NOT ROTATE.

- a) Check the wrap arm proportional flow valve (see fig 16.4) This gets a PWM signal and cannot be read with a voltmeter. However you can check the connections and if possible put 12 V directly onto it. This will give flow to the wrap arm (i.e full speed) so be careful! Just press the button briefly and if it moves there is the problem the PWM module in the junction box. Consult with your dealer.
- b) Check cross line relief valve (S4). (See fig. 13-2). Screw in one turn and test. If it does not have an effect screw back to original position.
- c) The safety valve, (S3, fig. 13-2), can be leaking, so that the oil is passing by the wrapping arm motor. Dismantle and try out if the sliding shaft can move freely.
- d) The control valve may be blocked. Dismantle and check if the valve works normally. Do not use sharp tools



- e) Check if the oil motor is working
Ask your dealer for advice BEFORE you make the problems bigger and repairing more difficult.
- f) If the emergency stop* has been activated. To start the machine the control box must be reset (See also chapter 5.0).

16.5 THE ROLLERS DO NOT ROTATE DURING WRAPPING.

- a). Check "Stop bale pulse" is set to 1 in operator set-up. See section 7.0
- b) Check the Rollers proportional flow valve (see fig 16.5) This gets a PWM signal and cannot be read with a voltmeter. However you can check the connections and if possible put 12 V directly onto it. This will give flow to the rollers (i.e full speed) so be careful! Just press the button briefly and if it moves there is the problem the PWM module in the junction box. Consult with your dealer.

16.6 THE LOAD ARM DOES NOT FUNCTION.

I. Is there enough flow going to the machine.

Remember the load arm is receiving the excess from the flow divider. Try increasing the tractor engine speed. Check the flow. Adjust the main flow divider if necessary.

II. Check the bypass valve

If this is receiving enough power and has free flow, the problem must lie in the solenoid valve.

III. Is there enough electric power going to the valves.

When the power source is tapped by several users at ones, the voltage can fall so much that all the functions will cut out, or only the width regulating. Check the power source and measure the voltage.

1814 Arc and s Hydraulic Circuit

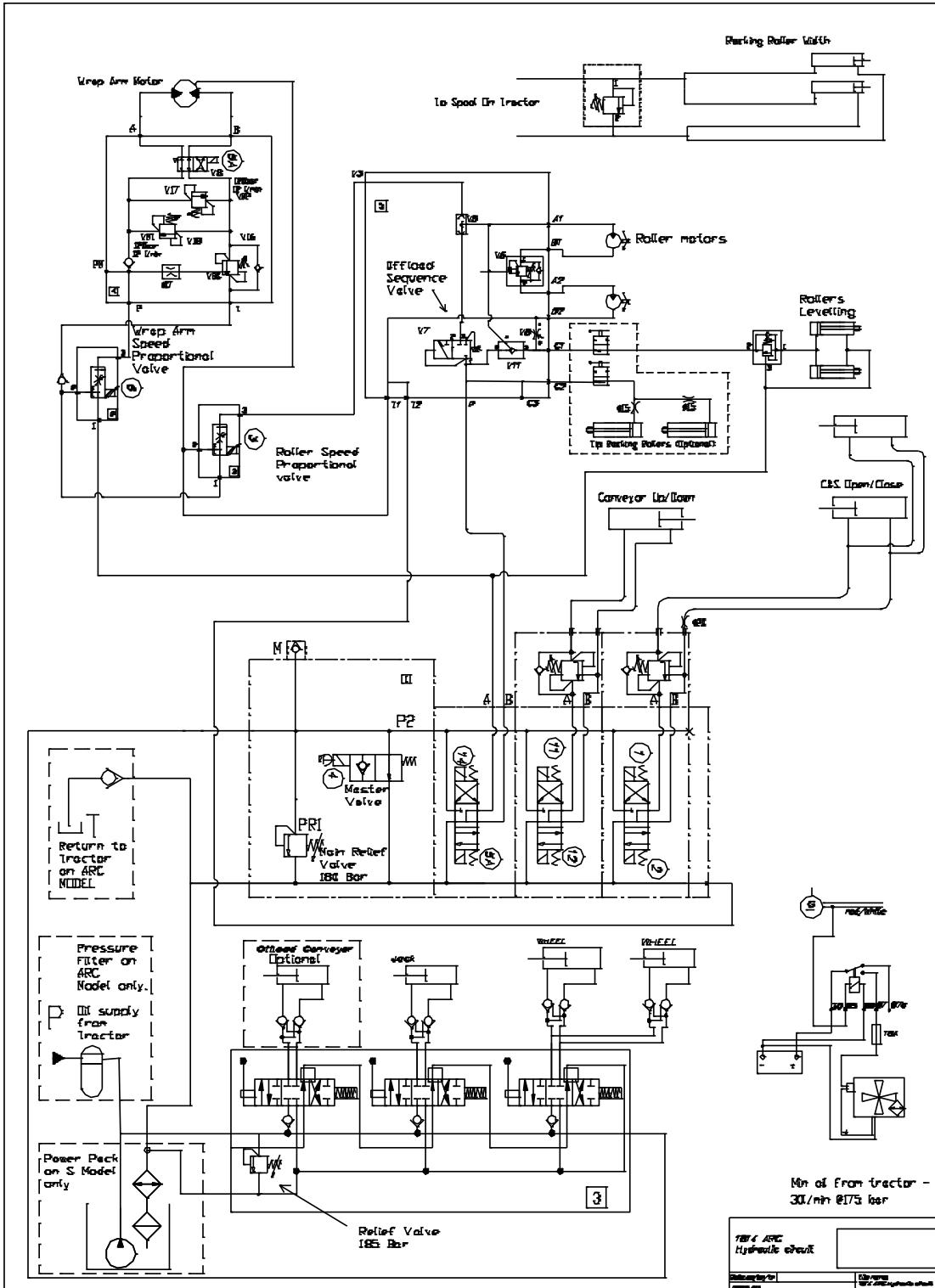



18.0 Declaration of conformity

EC DECLARATION OF CONFORMITY



ACCORDING TO DIRECTIVES 2006/42/EC

Manufacturer:
Tanco Autowrap Ltd
Bagenalstown
Co. Carlow
IRELAND

CERTIFIES THAT THE FOLLOWING PRODUCT:
TANCO AUTOWRAP
MODEL: 1814 Autowrap
SERIAL NO:

To which this declaration relates, corresponds to the essential requirements of the Directive 2006/42/EC.

To conform to these essential health and safety requirements, the provisions of the following harmonized standards were particularly considered:

ISO 12100, EN 294, prEN 703, EN ISO 13857, EN ISO 4254 - 1, prEN 982.

DATE: 01/11/2011

Signed: _____
Con Hourihane, Technical Manager