

**TANCO AUTOWRAP
450S/550S/550A MODEL 1995
OPERATORS HANDBOOK
AND
PARTS LIST
WD65-450S/550S/550A-M0595**

450S/550S MODELS

Bale Wrap Controller:

Connect direct to battery as per operating instructions and switch on. The programming of the Automatic Bale Wrap Controller is easily done by following the steps outlined below:

Once the unit is switched on, the number of required turntable revolutions appears on the right hand display. To change this press and hold the "hold to set" button, see fig. 6, then press the "set/reset" button. The first digit of the number will then blink and count from 0-9. Release the "set/reset" button at the required number. By pressing the "set/reset" again the second digit can be changed.

The monitor counts the number of bales per batch and the cumulative total. To see these, press the "bale count" button. The first number to appear is the batch total. If the button is held down for 10 seconds, a line will appear on the display, followed by the cumulative number wrapped. The batch count can be reset to 0 by holding the "bale count" button down and pressing the "set/reset" once. The cumulative total cannot be returned to zero.

To enable you to understand how the controller works, here is a brief resume of its functions.

- (1) After two revolutions of the turntable the actuator pushed open the Cut and Start, this action takes 0.5 secs until the latch engages, then after 6 revolutions of the turntable the actuator closes for a period of 5.5 seconds and stops in the rest position. When the turntable is tipped, the magnet operates the sensor which activates the linear actuator which closes fully and in doing so, trips the latch releasing the gripper arm which slams closed under the spring pressure, cutting the film end, at the same time gripping the film for the next bale

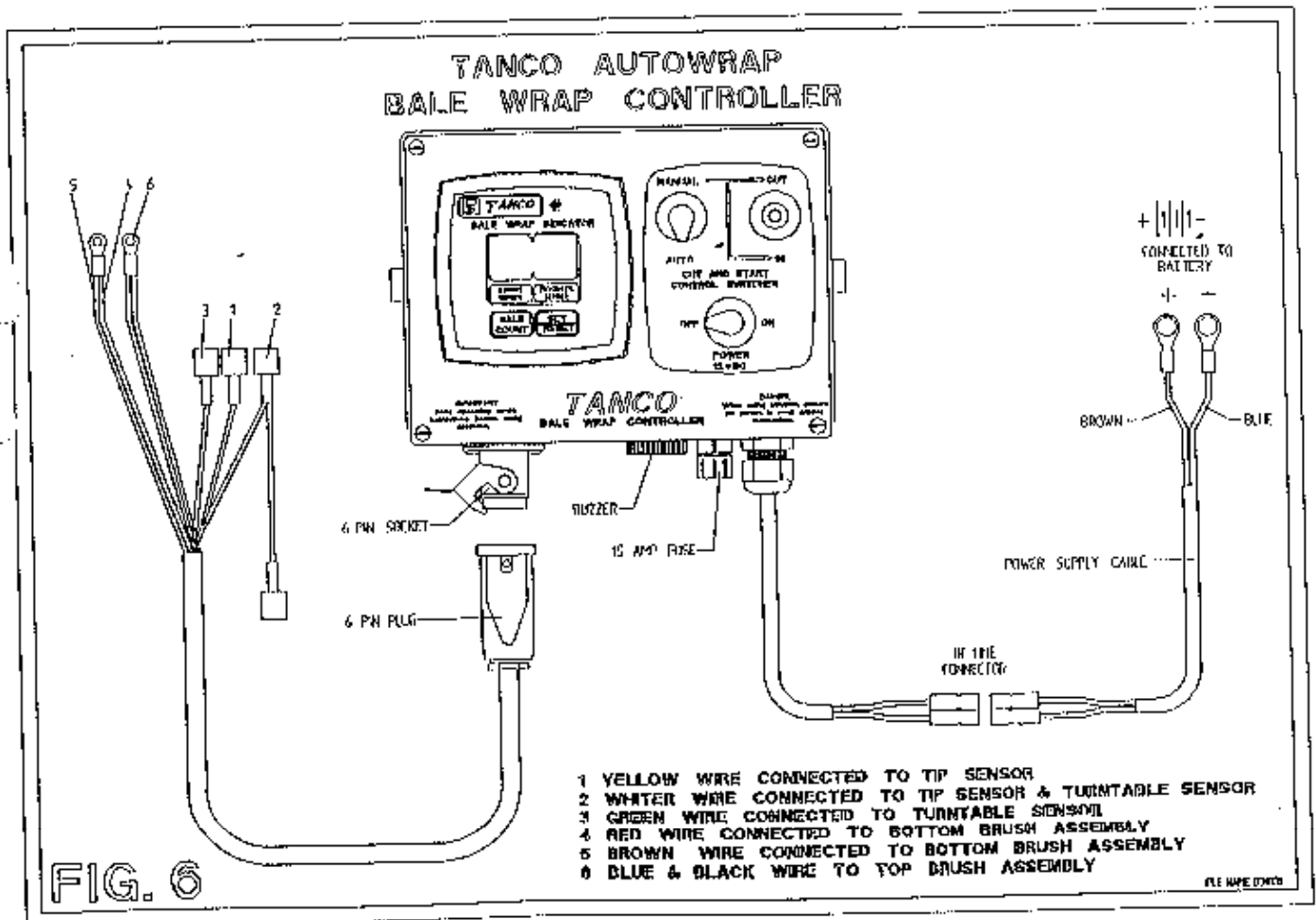

TANCO AUTOWRAP FILM THREADING DIAGRAM

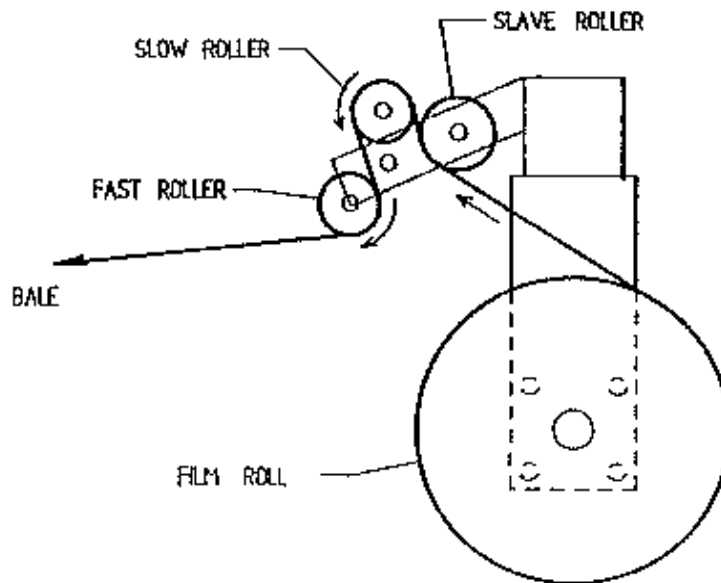

FILM ADJUSTMENT

CENTRE OF FILM ROLL MUST BE IN LINE WITH CENTRE OF BALE AND FILM MAST SHOULD BE VERTICAL.

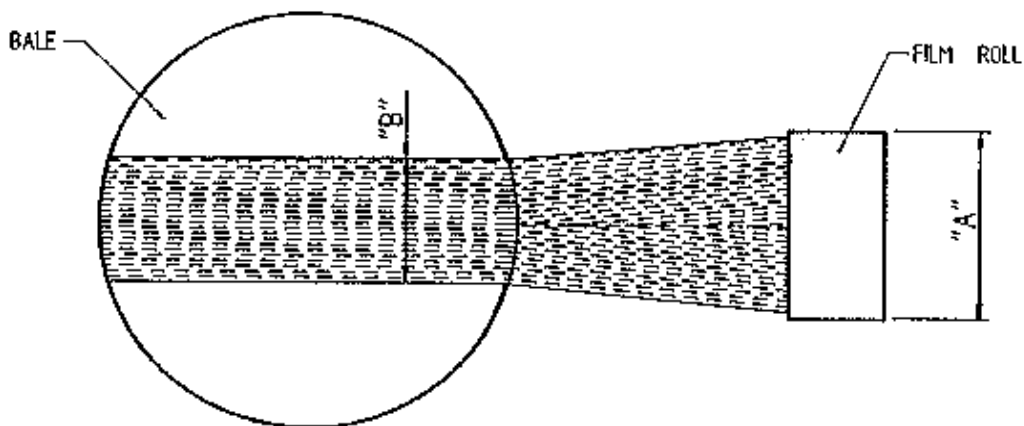

FILM ROLL WIDTH "A"	FILM WIDTH ON END OF BALE "B"
500 mm	400 mm
750 mm	600 mm

Fig. 1

FILE NAME W060-LA21

**TANCO AUTOWRAP CONSTANT INDEXING
GEARBOX CHAIN DRIVE TENSIONING SYSTEM (1995)**

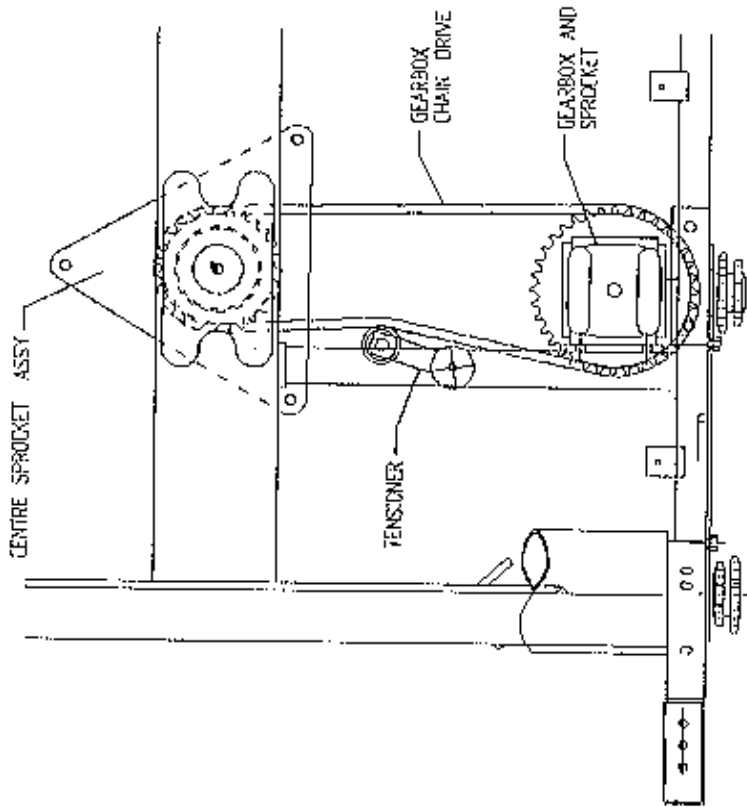
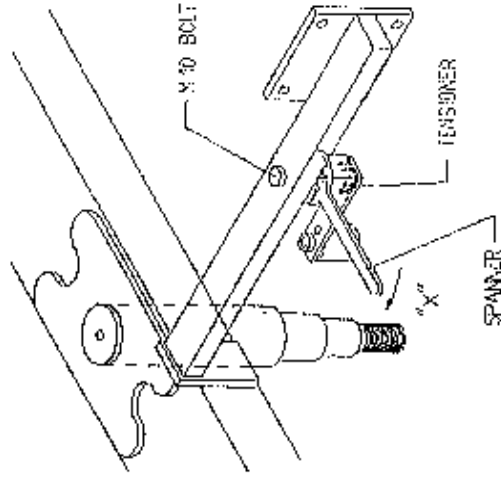

Fig. 2

CHAIN TENSIONING PROCEDURE

1. LOOSEN M10 BOLT SECURING CHAIN TENSOR.
2. TENSION CHAIN BY ADJUSTING TENSOR USING SPANNER IN DIRECTION OF ARROW "X" UNTIL SETTING OF 15°-20° IS REACHED.
3. RE-TIGHTEN M10 BOLT TO SECURE TENSOR IN POSITION.



ROLLER CHAIN DRIVE TENSIONING SYSTEM

CHAIN TENSIONING PROCEDURE

1. LOOSEN M10 BOLT SECURING CHAIN TENSOR.
2. TENSION CHAIN BY MOVING CHAIN TENSOR OUTWARDS IN SLOT.
3. RE-TIGHTEN M10 BOLT TO SECURE TENSOR IN POSITION.

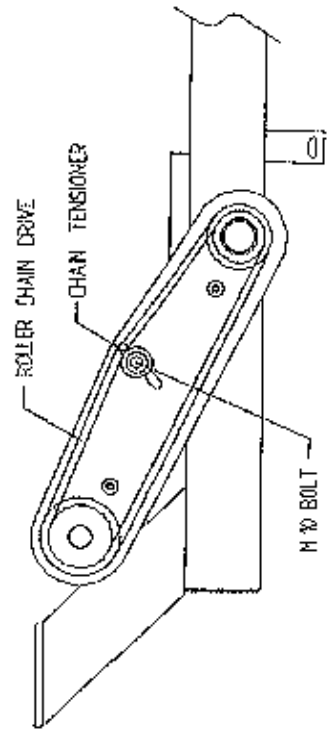

Fig. 3

TANCO AUTOWRAP 1995 MODEL TURNABLE CHAIN DRIVE TENSIONING SYSTEM

TENSIONING PROCEDURE

1. TIP UP MACHINE AND SUPPORT WITH A PROP.
 2. SLACKEN M12 CLAMPING BOLTS SLIGHTLY.
 3. SLACKEN LOCKNUT A.
 4. ADJUST NUT B UNTIL THERE IS 6mm - 10mm DEFLECTION ON CHAIN.
- NOTE WARNING:
DO NOT OVER TENSION CHAIN AS MOTOR WILL BE DAMAGED
5. TIGHTEN LOCKNUT A.
 6. TIGHTEN M12 CLAMPING BOLTS.

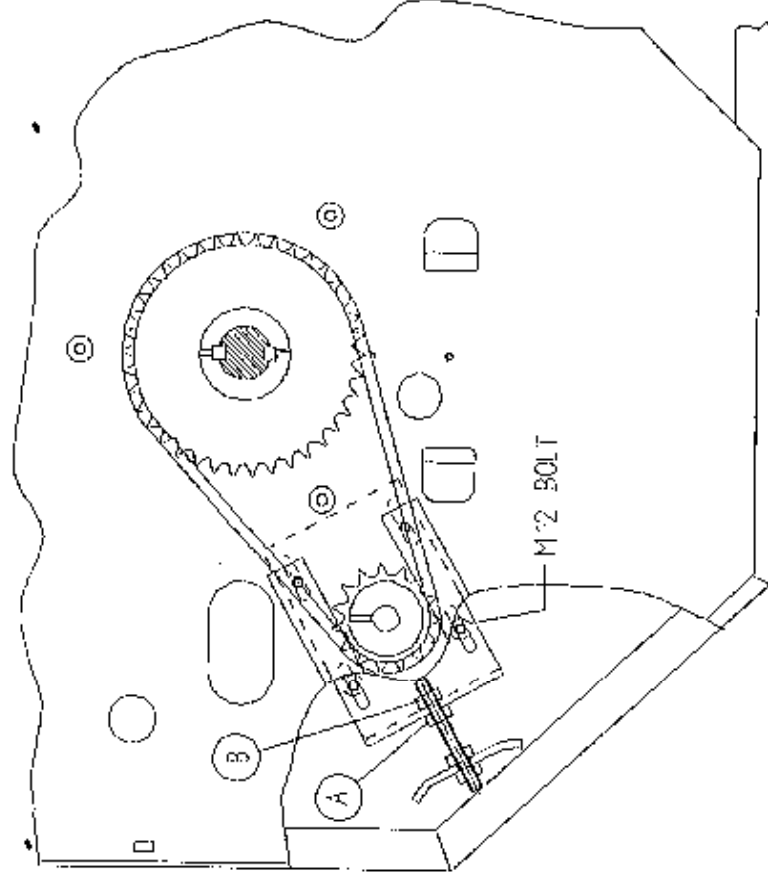

Fig. 8

FILM ADAPTOR

OPERATING INSTRUCTION

500mm wide film rolls are used as standard on 250, 350, & 450 autowrap Models while 750mm wide film rolls are used as standard on 550 model. If however, it is found necessary to use 500mm wide rolls along with 750mm film dispenser the following instructions must be adhered to: (NOTE: Failure to do so will result in inadequate wrapping and bale spoilage).

1. Fit film adaptor to top end of 500mm wide film roll as shown opposite.
2. Remove drive chain from inner set of sprockets and fit to outer set of sprockets as shown in Fig. below.
3. Re-tension chain.
4. Adjust height of film mast so that centre of film roll is in line with centre of bale on the turntable.
5. Adjust bale wrap indicator setting from 15 to 22 revolutions for 120cm x 120cm bales. (See page for guide to bale wrap indicator settings. See Table 1).

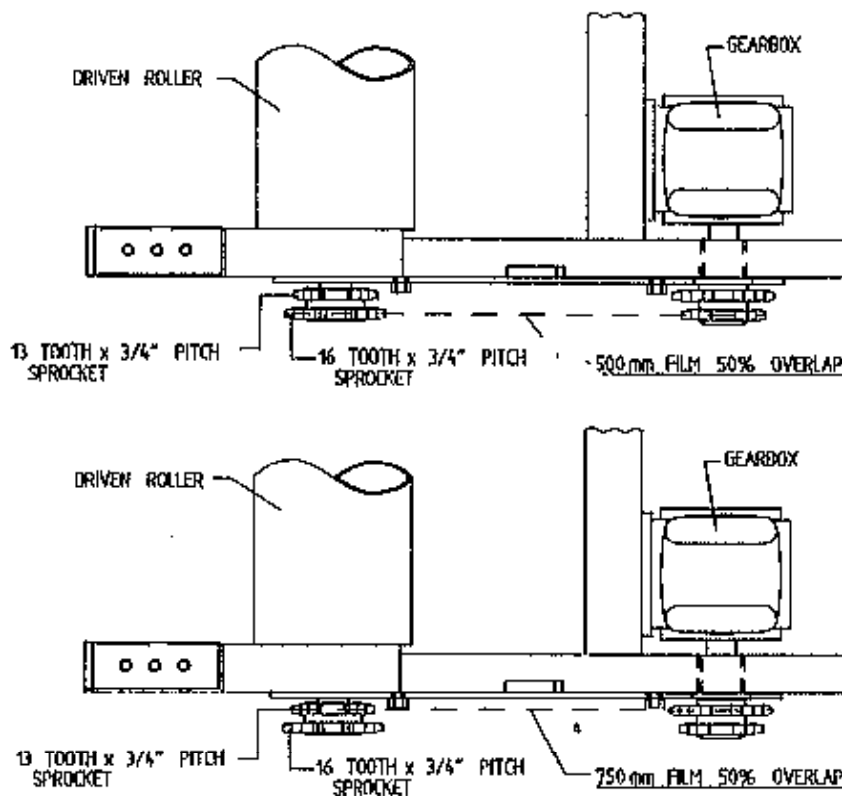
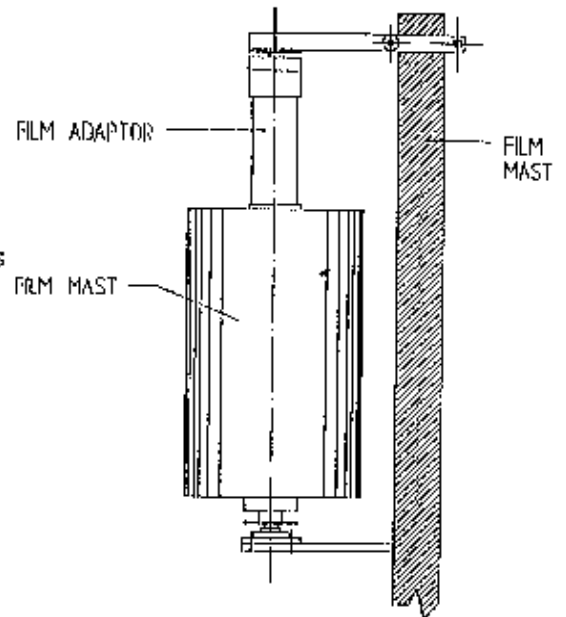
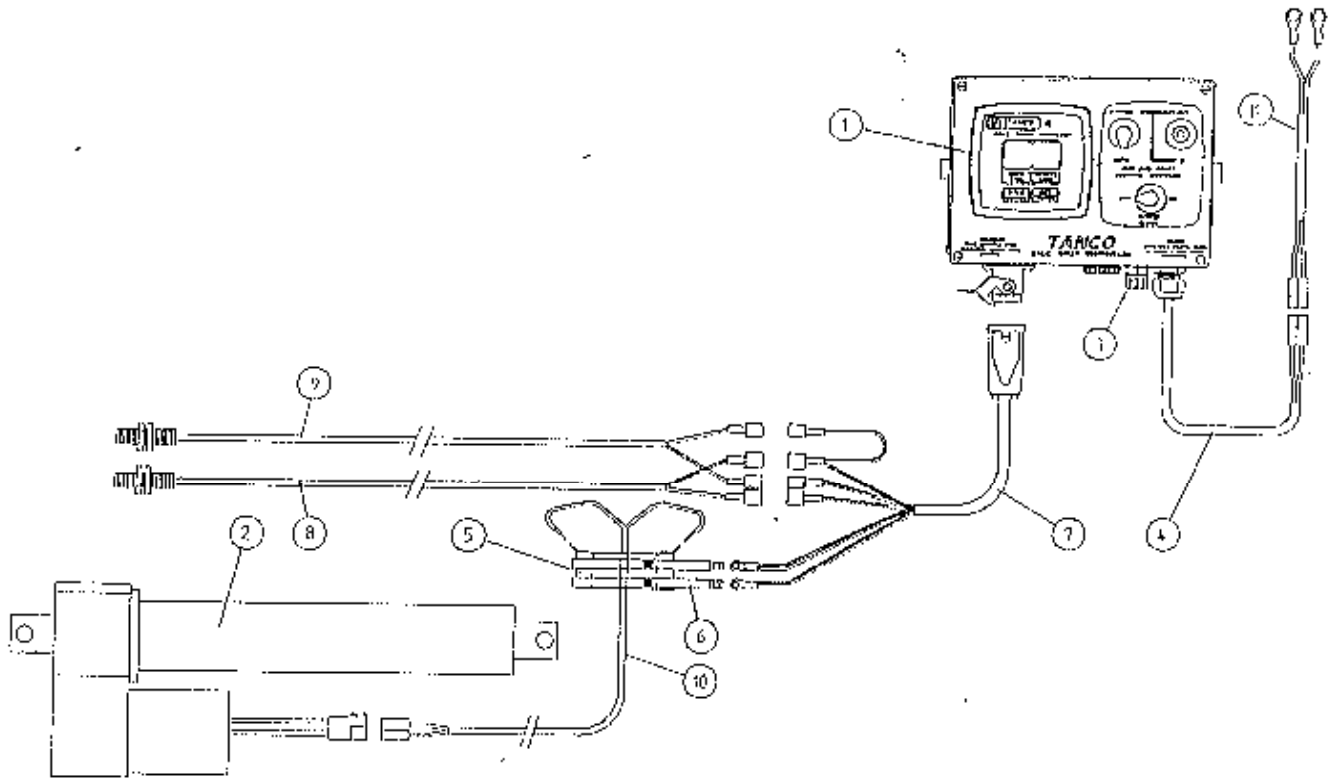
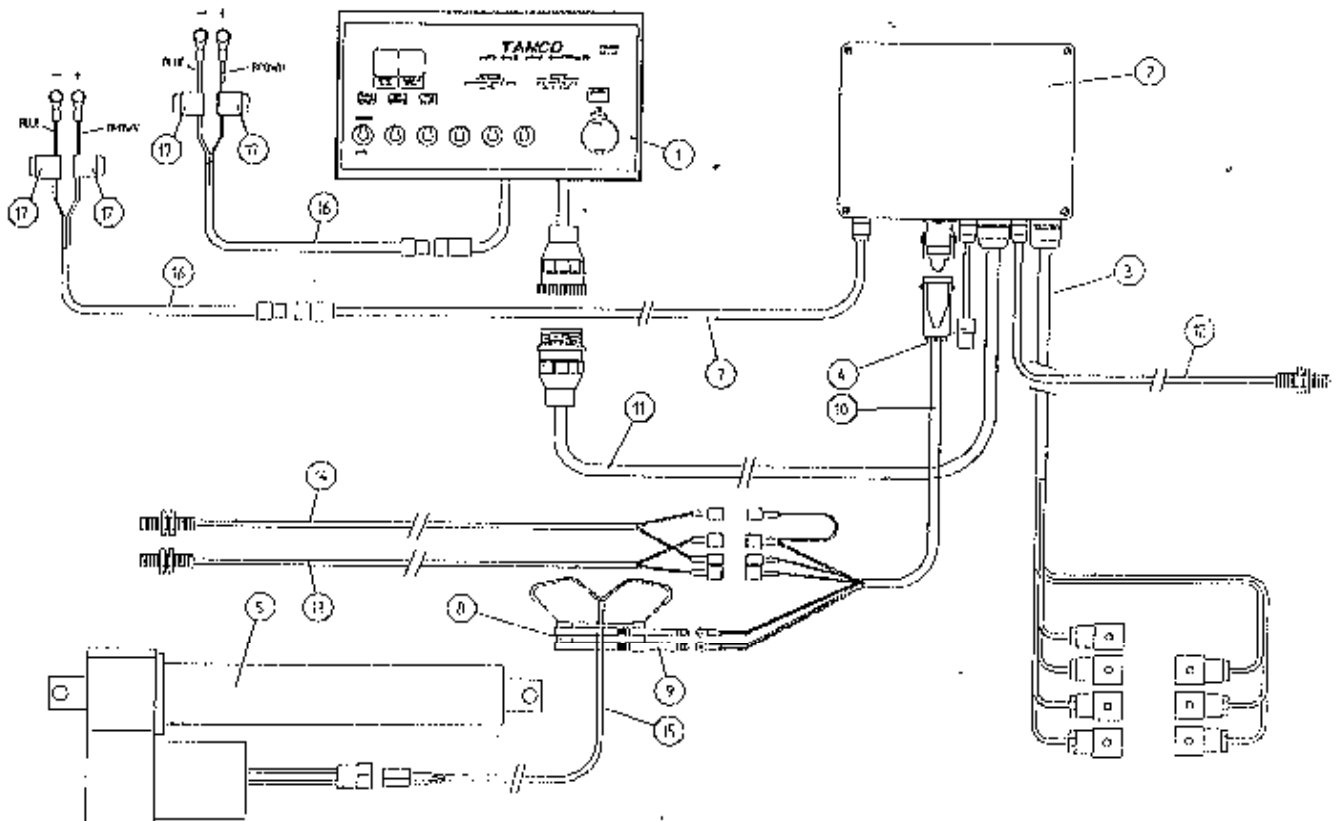

Fig. A

TANCO AUTOWRAP 250SL/450S/550S/1050S/1250SELECTRICAL COMPONENTSPARTS LIST

ITEM NO.	DESCRIPTION	QTY	PART-NO
1.	CONTROL BOX	1	D6049
2.	WARNER LINEAR ACTUATOR	1	ZD605-510
3.	1 1/4" FUSE HOLDER	1	ZD606-100
4.	MAIN FLY LEAD FOR CONTROLLER	1	ZD606-060
5.	SLIP RING ASSY.	1	ZD605-308
6.	BRUSHES	2	ZD605-302
7.	7 CORE CABLE C/W HEARTING PLUG	1	D605-7C
8.	ROTATING SENSOR	1	ZD606-RS
9.	TIP SENSOR	1	ZD606-TS
10.	TWO CORE CABLE FOR SLIP RING	1	D605-02C
11.	MAIN BATTERY LEAD FOR CONTROLLER	1	ZD606-030

TANCO AUTOWRAP 550A/1050A MODELS
ELECTRICAL COMPONENTS



PARTS LIST

ITEM NO	DESCRIPTION	QTY	PART-NO
1.	CONTROL BOX	1	D606
2.	JUNCTION BOX (3BANK SPOOL VALVE)	1	ZDG-JB3
3.	LOOM FOR VALVE C/E HIRSCHMAN	1	ZD606-082
4.	SYSTEM PRESSURE LEAD	1	ZD606-070
5.	WRANER LINEAR ACTUATOR	1	ZD605-510
6.	1 1/4" FUSE HOLDER	1	ZD606-100
7.	MAIN LEAD FOR JUNCTION BOX	1	ZD606-050
8.	SLIP RING ASSY	1	ZD605-308
9.	BRUSHES	1	ZD605-302
10.	7 CORE CABLE C/W HEARTING PLUG	1	D605-7C
11.	24 CORE INTERCONNECTING LEAD C/W CONNECTORS	1	D605-24C
12.	LIFT ARM SENSOR	1	ZD606-LAS
13.	ROTATING SENSOR	1	ZD606-RS
14.	TIP SENSOR	1	ZD606-TS
15.	TWO CORE CABLE FOR SLIP RING	1	D605-02C
16.	MAIN BATTERY LEAD	2	ZD606-030
17.	IN-LINE FUSE	4	ZD606-100

TANCO AUTOWRAP 450 S/550 S MODELS (TRAILED) 1995 HYDRAULIC CIRCUIT DIAGRAM

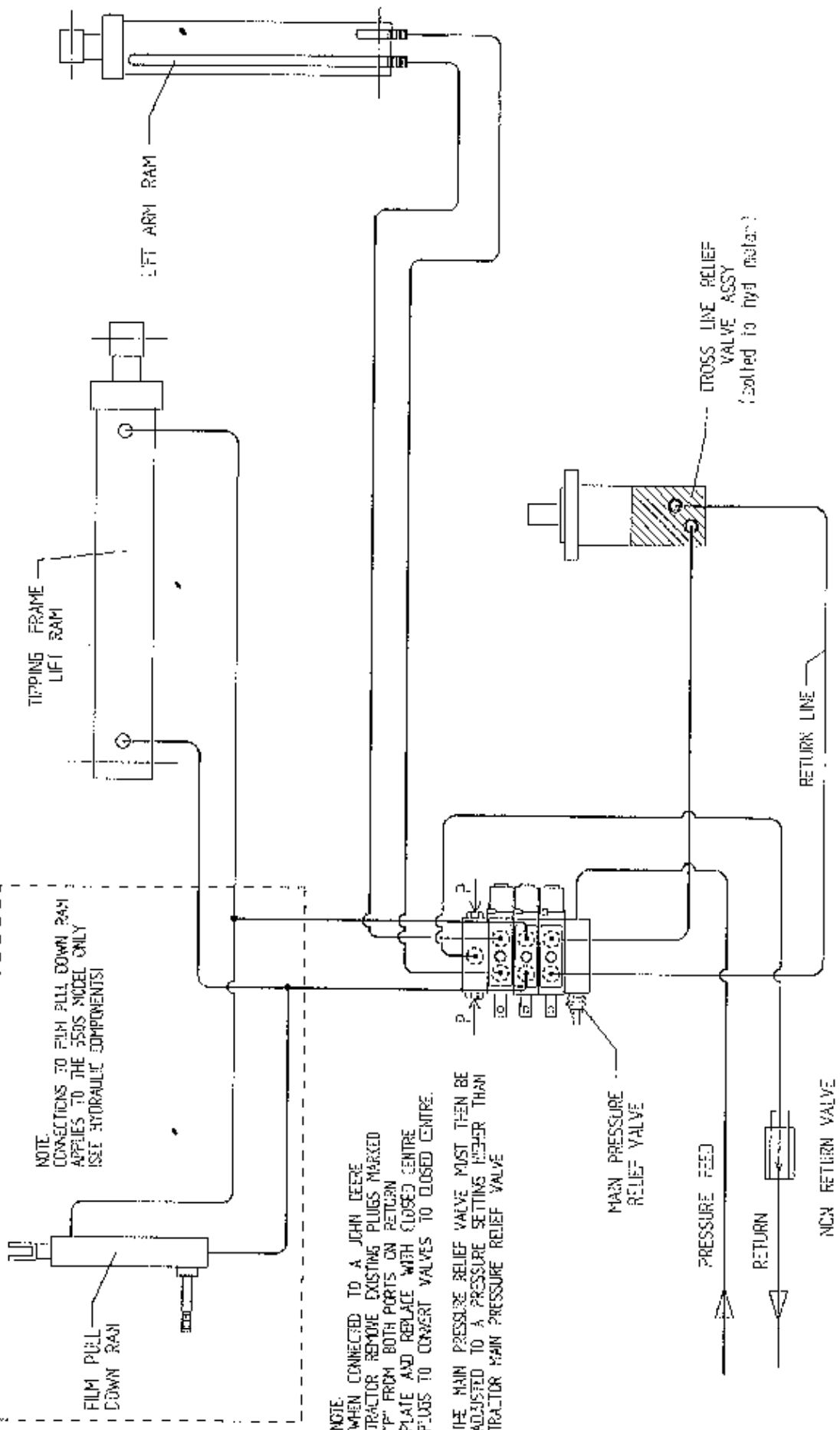

NOTE: CONNECTIONS TO FILM PULL DOWN RAM APPLIES TO THE 550S MODEL ONLY (SEE HYDRAULIC COMPONENTS)

NOTE: WHEN CONNECTED TO A JOHN DEERE TRACTOR REMOVE EXISTING PLUGS MARKED "P" FROM BOTH PORTS ON RETURN PLATE AND REPLACE WITH CLOSED CENTRE PLUGS TO CONVERT VALVES TO CLOSED CENTRE.

THE MAIN PRESSURE RELIEF VALVE MUST THEN BE ADJUSTED TO A PRESSURE SETTING HIGHER THAN TRACTOR MAIN PRESSURE RELIEF VALVE

TANCO AUTOWRAP 1995 MODEL
RIDGID BALE RAMP ASSY

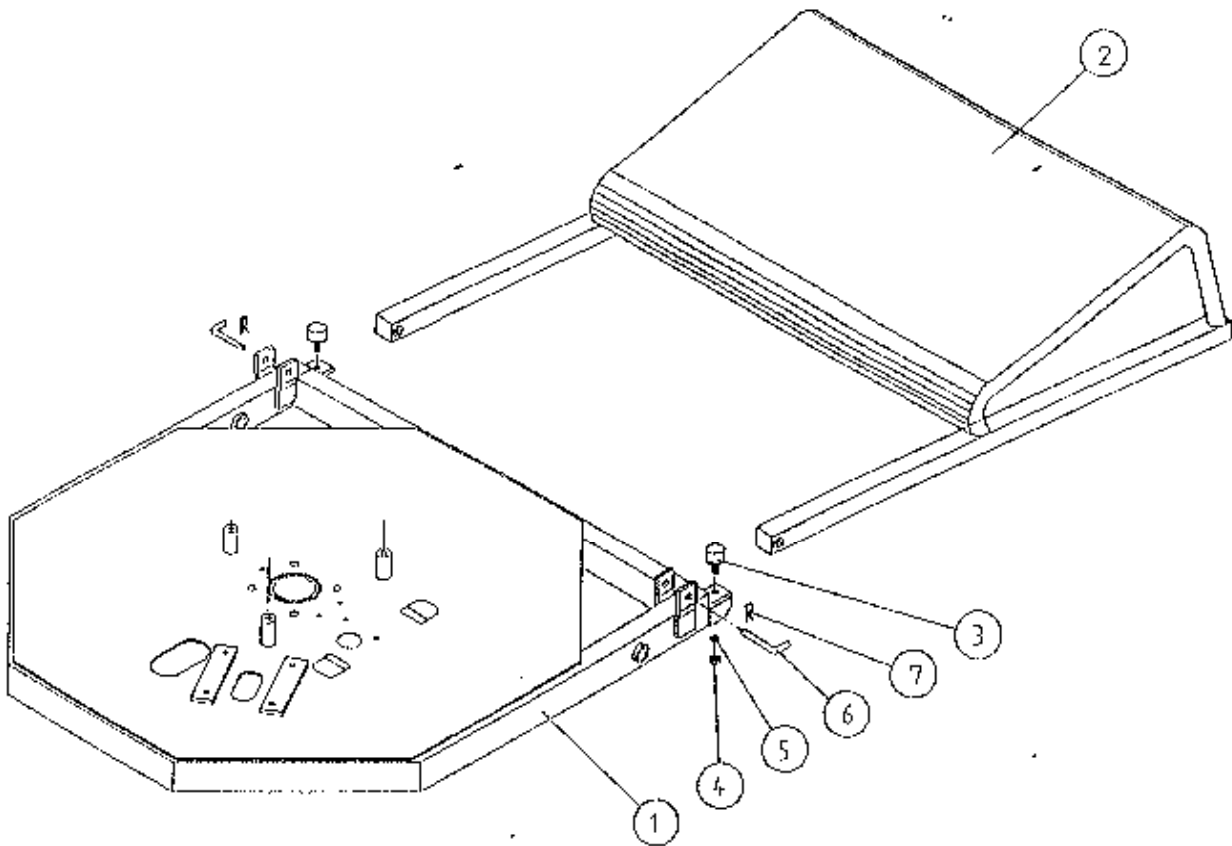

PARTS LIST

ITEM NO	DESCRIPTION	QTY	PART-NO.
1.	TIPPING FRAME ASSY	1	WD64-TF
2.	BALE RAMP ASSY	1	WD60-BR
3.	BUFFER 50mm DIA x 40mm LONG	2	Z40-20
4.	M10 HEX NUT	2	Z18-10
5.	10mm DIA SPRING WASHER	2	Z12-02-10
6.	BISSEL PIN	2	Z03-22-AW100
7.	4mm "R" CLIP	2	Z36-02

TANCO AUTOWAP 1995 MODEL HYDRAULIC BALE RAMP

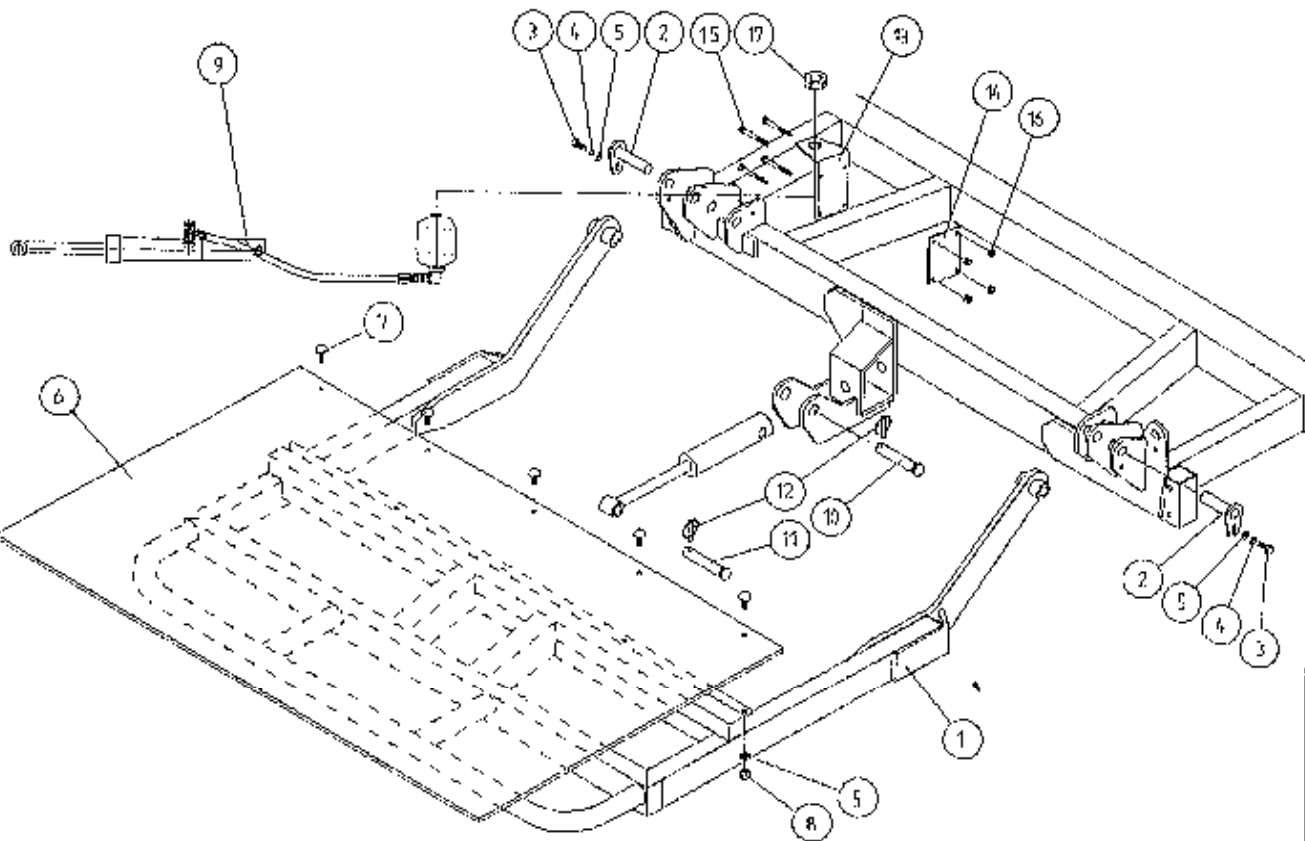

INSTRUCTIONS FOR RECHARGING HYDRAULIC CYLINDER

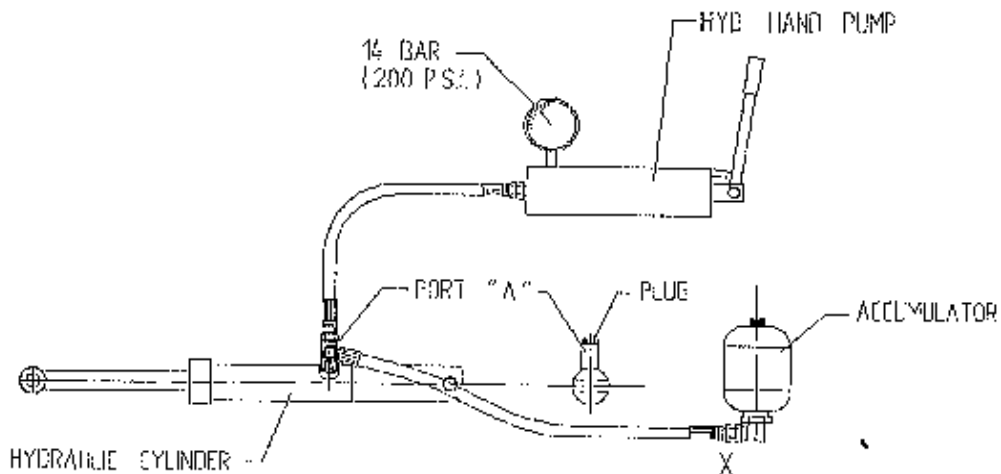

1. REMOVE PLUG FROM PORT "A".
2. CONNECT HOSE FROM HYD. HAND PUMP TO PORT "A".
3. CHARGE CYLINDER TO A PRESSURE OF 14 BAR (200 P.S.I.)
4. BLEED AIR FROM SYSTEM BY SLACKENING HOSE CONNECTION AT BASE OF ACCUMULATOR MARKED X. RETIGHTEN CONNECTION.
5. REMOVE PUMP HOSE FROM PORT "A" AND RE-FIT PLUG.

WD64-PL25

TANCO AUTOWRAP 1995 MODEL
HYDRAULIC BALE RAMP

PARTS LIST

ITEM	DESCRIPTION:	QTY:	PART NO:
1	HYDRAULIC BALE RAMP ASSY	1	WD65-HBRF
2	RAMP MAIN PIVOT PIN C/W GREASE NIPPLE	2	Z03-01-905
3	M10 HEX HD SET X 20mm LONG TUFLOCK	2	Z26-060ST
4	10MM DIA MACHINED FLAT WASHER	2	Z11-02-10
5	10MM DIA SPRING WASHER	12	Z12-02-10
6	BALE MAT	1	Z05-02-BRH
7	M10 X 30MM LONG CUP HD.SQ BOLTS	5	Z13-112
8	M10 HEX NUTS	5	Z18-10
9	HYDRAULIC RAM C/W ACCUMULATOR	1	Z01-01-AWD
10	SPAREX PIN	1	Z03-04-74
11	SPAREX PIN	1	Z03-04-73
12	7/16 DIA LINCH PIN	2	Z03-22-06
13	ACCUMULATOR MOUNTING PLATE	1	WD65-AMP
14	CLAMPING PLATE	1	WD65-231
15	M8 HEX HD BOLT X 80MM LONG	4	Z26-050B
16	M8 LOCKNUT	4	Z23-08
17	M28 X 1.5 PITCH HEX NUT	1	Z18-28

**TANCO AUTOWRAP TRAILED MODELS
LIGHTING KIT**

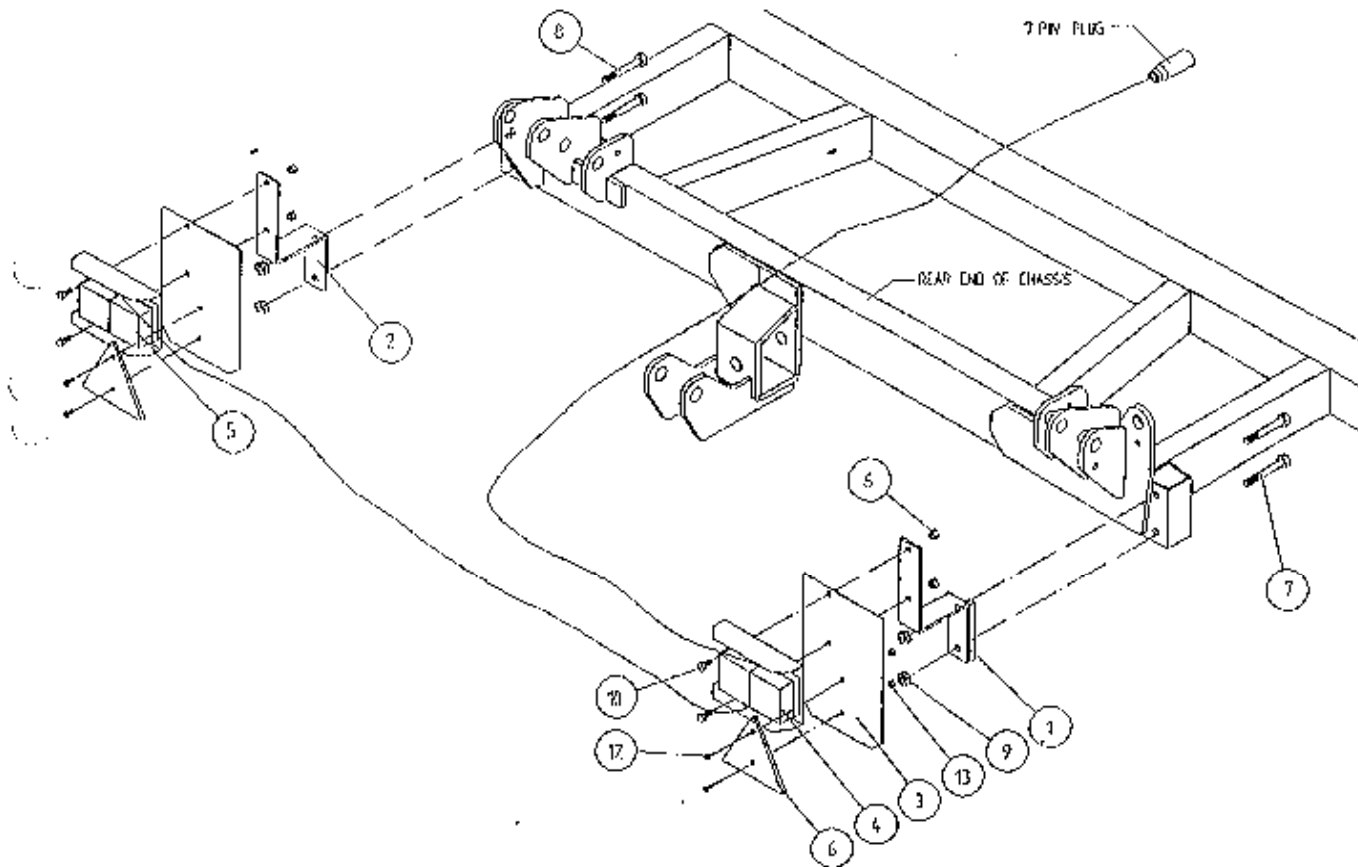

PARTS LIST

ITEM NO	DESCRIPTION	QTY	PART-NO.
1.	LIGHT MOUNTING BRACKET RHS	1	WD60-LMB
2.	LIGHT MOUNTING BRACKET LHS	1	WD60-899
3.	LIGHT MOUNTING PLATE	2	WD60-898
4.	LIGHT CLUSTER RHS	1	Z05-30R
5.	LIGHT CLUSTER LHS	1	Z05-30L
6.	TRIANGULAR REFLECTOR	2	Z04-62
7.	M12 HEX HD BOLT X 100 LONG	2	Z26-092B
8.	M12 HEX HD BOLT X 90 LONG	2	Z06-091B
9.	M12 LOCKNUT	4	Z23-12
10.	M8 HEX HD SET X 20 LONG	4	Z26-39S
11.	M8 LOCKNUT	4	Z23-08
12.	M6 CHEESE HEAD SET X 20 LONG	4	Z13-15
13.	M6 LOCKNUT	4	Z23-06

TANCO AUTOWRAP 550 A MODEL (1995) HYDRAULIC CIRCUIT DIAGRAM

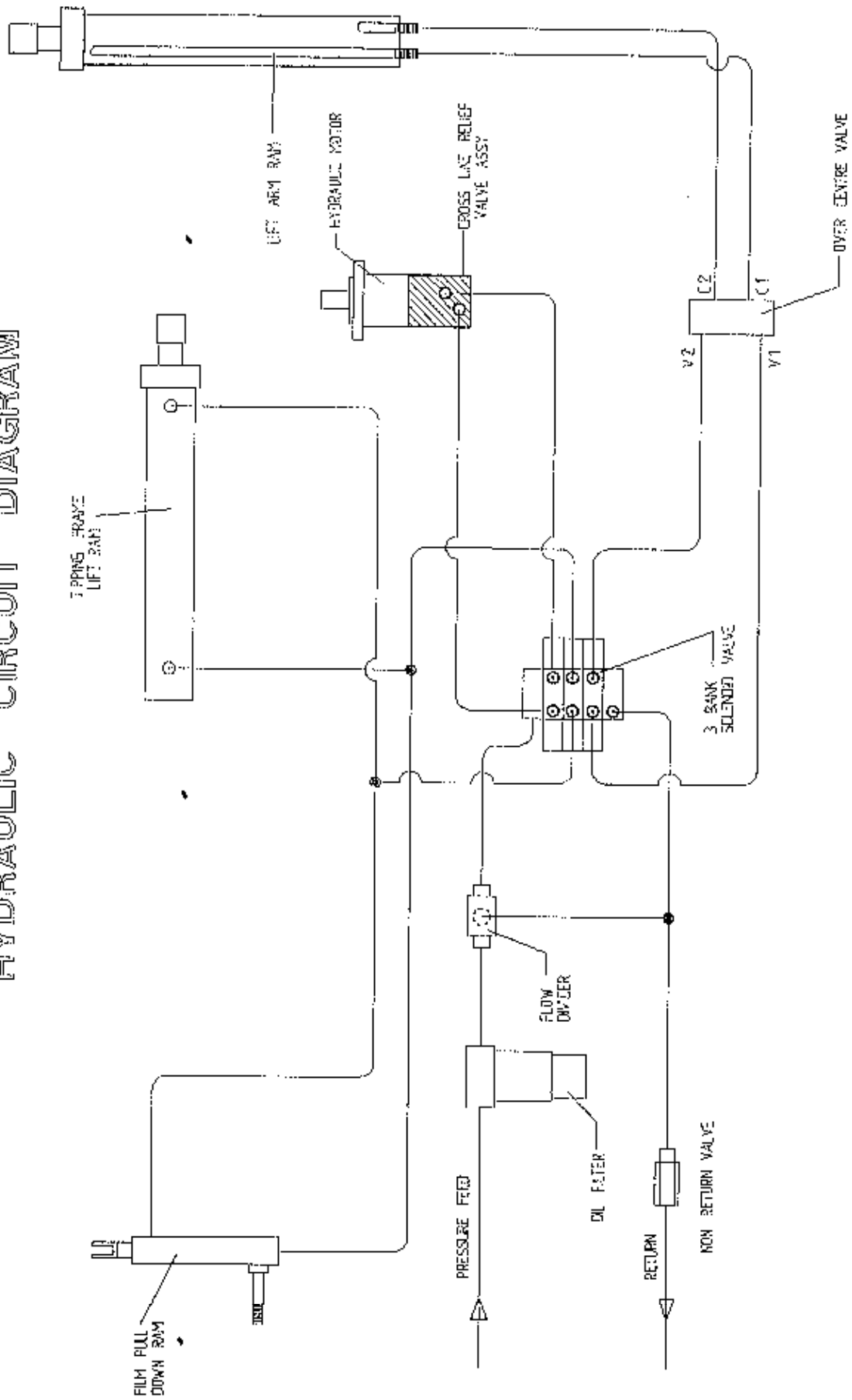

TANCO AUTOWRAP 450 S/550 S TRAILED MODELS 1995
HYDRAULIC COMPONENTS

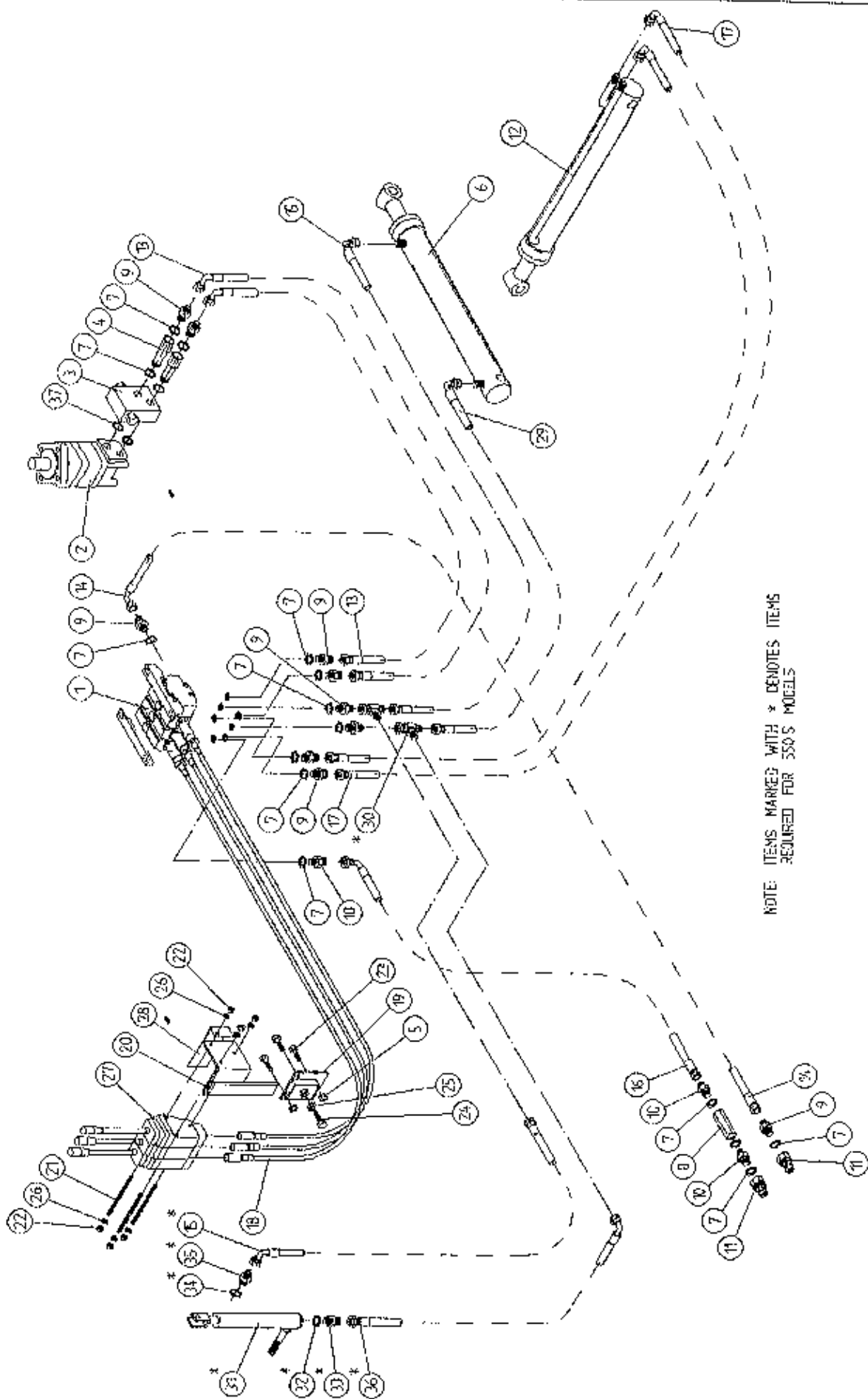

NOTE: ITEMS MARKED WITH * DENOTES ITEMS
REQUIRED FOR 550 S MODELS

TANCO AUTOWRAP 450 S/550 S MODELS (TRAILED) 1995
HYDRAULIC COMPONENTS (DIN)

PARTS LIST

ITEM NO.	DESCRIPTION	QTY.	PART-NO
1	3 BANK SPOOL VALVE (DIN)	1	Z01-03-018D
2	HYDRAULIC MOTOR (C.L)	1	Z01-02-RF200
3	CROSS LINE RELIEF VALVE	1	Z01-03-004
4	1/2" BSP BOTTOM BANJO BOLT (SPECIAL)	2	Z01-03-002B
5	M10 LOCKNUT	3	Z23-10
6	HYD. RAM (FOR TIPPING FRAME)	1	Z01-01-AR687
7	1/2" DOWTY WASHER	18	Z01-04-03
8	1/2" NON RETURN VALVE	1	Z01-03-017
9	1/2" X 3/8" ADAPTOR	10	Z01-06-06-08
10	1/2" X 1/2" ADAPTOR	3	Z01-06-08-08
11	1/2" MALE END Q/R COUPLING	2	Z01-15-081
12	HYD. RAM (FOR LEFT ARM)	1	Z01-01-AW
13	132" ST/90 3/8" D/W HOSE	2	Z38-R2-132-S9
14	84" ST/90 3/8" D/W HOSE	1	Z38-R2-84-S9
15*	72" ST/90 3/8" D/W HOSE	1+1	Z38-R2-72-S9
16	84" ST/90 1/2" S/W HOSE	1	Z12-R1-84-S9
17	108" ST/90 3/8" D/W HOSE	2	Z38-R2-108S9
18	3 1/2" METER ACTUATOR CABLES	3	Z004-03-0075
19	ACTUATOR MTG. BRACKET (LOWER)	1	WD65-AML
20	ACTUATOR MTG. BRACKET (UPPER)	1	WD65-AMU
21	TIE BOLT (M8 X 150MM LONG)	3	WSB150
22	M8 HEX NUT	6	Z18-08
23	M10 HEX HD. SETS X 40MM LONG	3	Z26-064S
24	M12 HEX HD. SET X 40MM LONG	1	Z26-084S
25	M12 HEX NUT	1	Z18-12
26	8MM DIA SPRING WASHER	6	Z12-02-08
27	ACTUATOR LEVERS	3	Z004-03-009
28	STICKER MOUNTING PLATE	1	WD60-794
29	60" ST/90 3/8" D/W HOSE	1	Z38-R2-60-S9
30*	3/8" FEMALE X 3/8" MALE/MALE "T" PIECE	2	Z01-12-002
31*	HYDRAULIC RAM D/A	1	Z01-01-AW25
32*	3/8" DOWTY WASHER	1	Z01-04-02
33*	3/8" X 3/8" ADAPTOR FITTED WITH 0.06" RESTRICTOR	1	Z01-03-40
34*	1/4" DOWTY WASHER	1	Z01-04-01
35*	1/4" X 3/8" ADAPTOR	1	Z01-06-04-06
36*	48" ST/90 3/8" D/W HOSE	1	Z38-R2-48-S9

* DENOTES ADDITIONAL ITEMS REQUIRED FOR 550S MODELS

TANCO AUTOWRAP 550 A MODEL (1995)
HYDRAULIC COMPONENTS

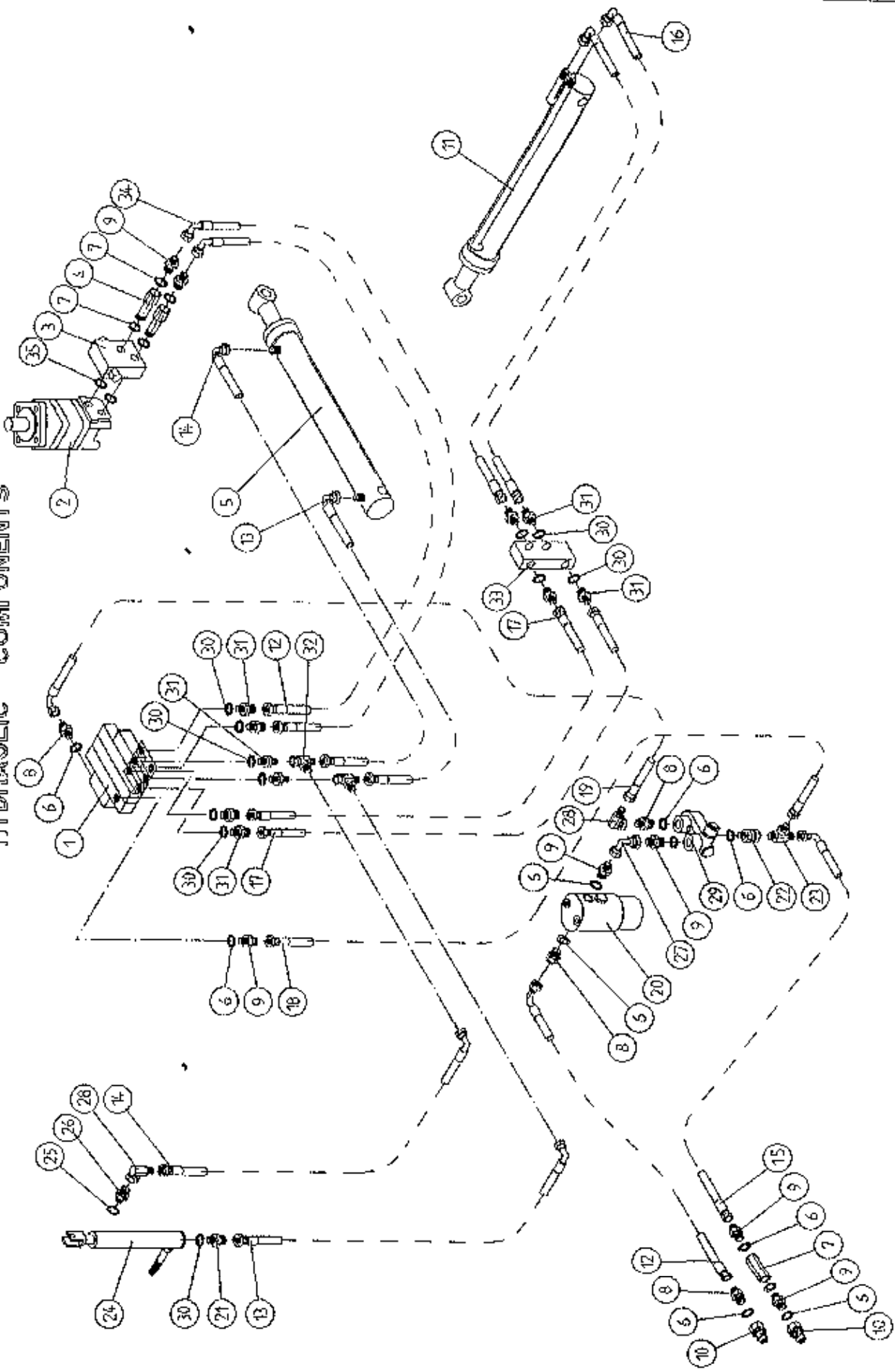

TANCO AUTOWRAP 550A MODEL (1995)

HYDRAULIC COMPONENTS

PARTS LIST

ITEM NO.	DESCRIPTION	QTY	PART-NO.
1.	3 BANK SOLENOID VALVE	1	Z01-03-10-A3
2.	HYDRAULIC MOTOR C.L.	1	Z01-02-RF200
3.	CROSS LINE RELIEF VALVE	1	Z01-03-004
4.	1/2" B.S.P. BOTTOM BANJO BOLT (SPECIAL)	2	Z01-03-002B
5.	HYDRULIC RAM (TIPPING FRAME)	1	Z01-01-AR687
6.	1/2" DOWTY WASHER	15	Z01-04-03
7.	1/2" NON RETURN VALVE	1	Z01-03-017
8.	1/2" X 3/8" ADAPTOR	6	Z01-06-06-08
9.	1/2" X 1/2" ADAPTOR	5	Z01-06-08-08
10.	1/2" MALE END Q/R COUPLING	2	Z01-15-081
11.	HYD. RAM (FOR LIFT ARM)	1	Z01-01-AW
12.	96" ST/90 3/8" D/W HOSE	1	Z38-R2-96-S9
13.	60" ST/90 3/8" D/W HOSE	2	Z38-R2-60-S9
14.	72" ST/90 3/8" D/W HOSE	2	Z38-R2-72-S9
15.	96" ST/90 1/2" D/W HOSE	1	Z12-R1-96-S9
16.	120" ST/90 3/8" D/W HOSE	2	Z38-R2-120S9
17.	16" ST/ST 3/8" D/W HOSE	2	Z38-R2T-17SS
18.	24" ST/ST 1/2" D/W HOSE	1	Z12-R2-24-SS
19.	24' ST/90 3/8" D/W HOSE	1	Z38-R2-24-S9
20.	FILTER	1	Z01-24-08
21.	3/8" X 3/8" ADAPTOR FITTED WITH 0.06" RESTRICTOR.	1	Z01-03-40
22.	1/2" MALE X 1/2" FEMALE ADAPTOR	1	Z01-05-08-08
23.	1/2" MALE "T" PIECE	1	Z01-11-003
24.	HYD. RAM D/A (PULL DOWN ARM)	1	Z01-01-AW25
25.	1/4" DOWTY WASHER	1	Z01-04-01
26.	1/4" X 3/8" ADAPTOR	1	Z01-06-04-06
27.	1/2" FEMALE X 1/2" FEMALE 90 ELBOW	1	Z01-14-018
28.	3/8" MALE/FEMALE 90 ELBOW	2	Z01-14-015
29.	IN LINE FLOW DIVIDER	1	Z01-03-10-A6
30.	3/8" DOWTY WASHER	11	Z01-04-02
31.	3/8" X 3/8" ADAPTOR	10	Z01-06-06-06
32.	3/8" MALE X 3/8" MALE X 3/8" FEMALE "T" PIECE	2	Z01-12-002
33.	OVER CENTRE VALVE	1	Z01-03-10-A8
34.	132" ST/90 3/8" D/W HOSE	2	Z38-R2-132-S9
35.	COPPER WASHER	2	Z01-04-15

INSTRUCTIONS FOR FITTING TWO WAY SOLENOID VALVE TO TANCO AUTOWRAP MODELS 550A, 1050A, 1250A.

REQUIRE WHEN OPERATING MACHINES ON TRACTORS WITH CLOSED CENTRE HYDRAULIC SYSTEMS.

1. Disconnect S/90 hose from inlet port on oil filter.
2. Connect port "T" on solenoid valve assembly to inlet port on oil filter.
3. Reconnect St/90 hose to port "P" on solenoid valve.
4. Connect 2 pin female connector to existing 2 pin connector at junction box.
5. Change the seventh controller function setting from n to j
See instruction manual for further information.

**TANCO AUTOWRAP 550A/1050A/1250A MODEL (1995)
TWO WAY SOLENOID VALVE KIT PART NO. Z01-03-016A**

PARTS LIST

ITEM NO	DESCRIPTION	QTY.	PART NO.
1	TWO WAY SOLENOID VALVE	1	Z01-03-01-A2
2	1/2" DOWTY WASHER	2	Z01-04-03
3	3/8" FEMALE x 1/2" MALE ADAPTOR	1	Z01-05-05-00
4	3/8" MALE/FEMALE 90 ELBOW	1	Z01-05-05
5	1/2" x 3/8" ADAPTOR	1	Z01-05-06-00

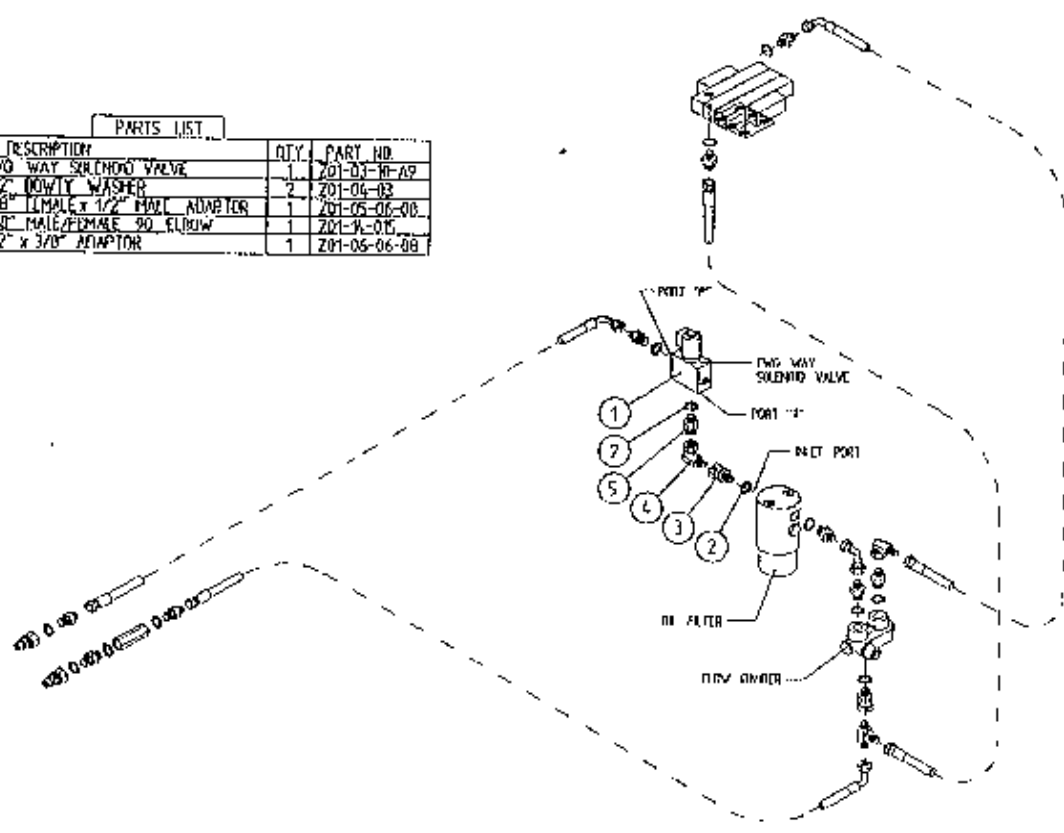

FILE NAME 9220C

**TANCO AUTOWRAP 1995 MODEL
TURNTABLE CHAIN DRIVE ASSEMBLY**

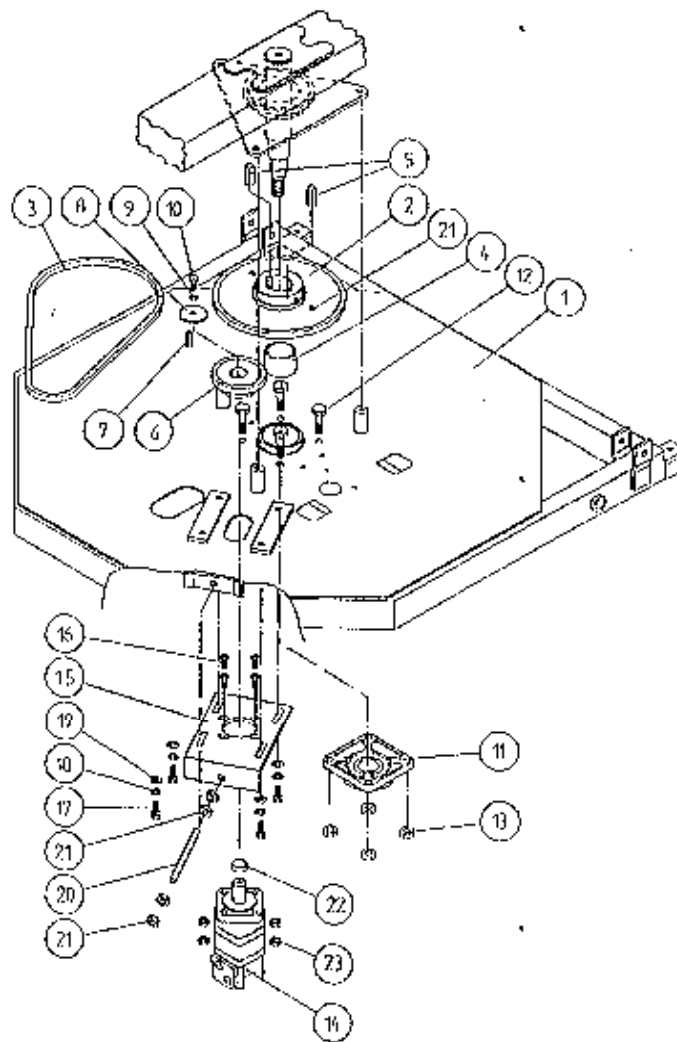

PARTS LIST

ITEM NO	DESCRIPTION	QTY	PART NO
1	TIPPING FRAME ASSY	1	WD64-TF
2	38 TOOTH X 1" PITCH SPROCKET	1	Z06-D64-38
3	CHAIN 1" PITCH X 54 PITCHES	1	Z09-AW6
4	SPINDLE SPACER	1	WD64-040
5	KEY 5/8" SQ X 50MM LONG	2	WD64-052
6	15 TOOTH X 1" PITCH SPROCKET	1	Z06-I60-046
7	KEY 5/16" SQ X 45MM LONG	1	WD64-053
8	LOCKING COLLAR	1	WD623-071
9	10MM DIA SPRING WASHER	1	Z12-02-10
10	3/8" UNC HEX HD SET 2 1" MM LONG	1	Z27-023S
11	2" DIA FLANGE BEARING C/W CAN LOCK COLLAR	1	Z06-19EC
12	5/8" UNF HEX HD SET X 2" LONG	4	Z31B-064
13	5/8" UNF LOCKNUT	4	Z20-10
14	HYDRAULIC MOTOR	1	Z01-02-RF200
15	HYDRAULIC MOTOR MOUNTING PLATE	1	WD64-001
16	M12 X 40MM ALLEN HD O/S SCREW	4	Z13-5-12
17	M12 HEX HD SET X 30MM LONG	4	Z26-082S
18	12MM DIA SPRING WASHER	4	Z12-02-12
19	12MM DIA FLAT WASHER	4	Z10-02-12
20	M16 THREADED BAR X 150MM LONG	1	WD64-038
21	M16 HEX NUTS	4	Z18-16
22	SPACER	1	WI60-093
23	M12 LOCKNUTS	4	Z23-12

TANCO AUTOWRAP 1995 MODEL

CONSTANT INDEXING DRIVE ASSY

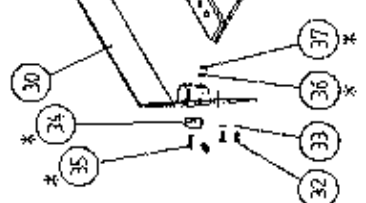
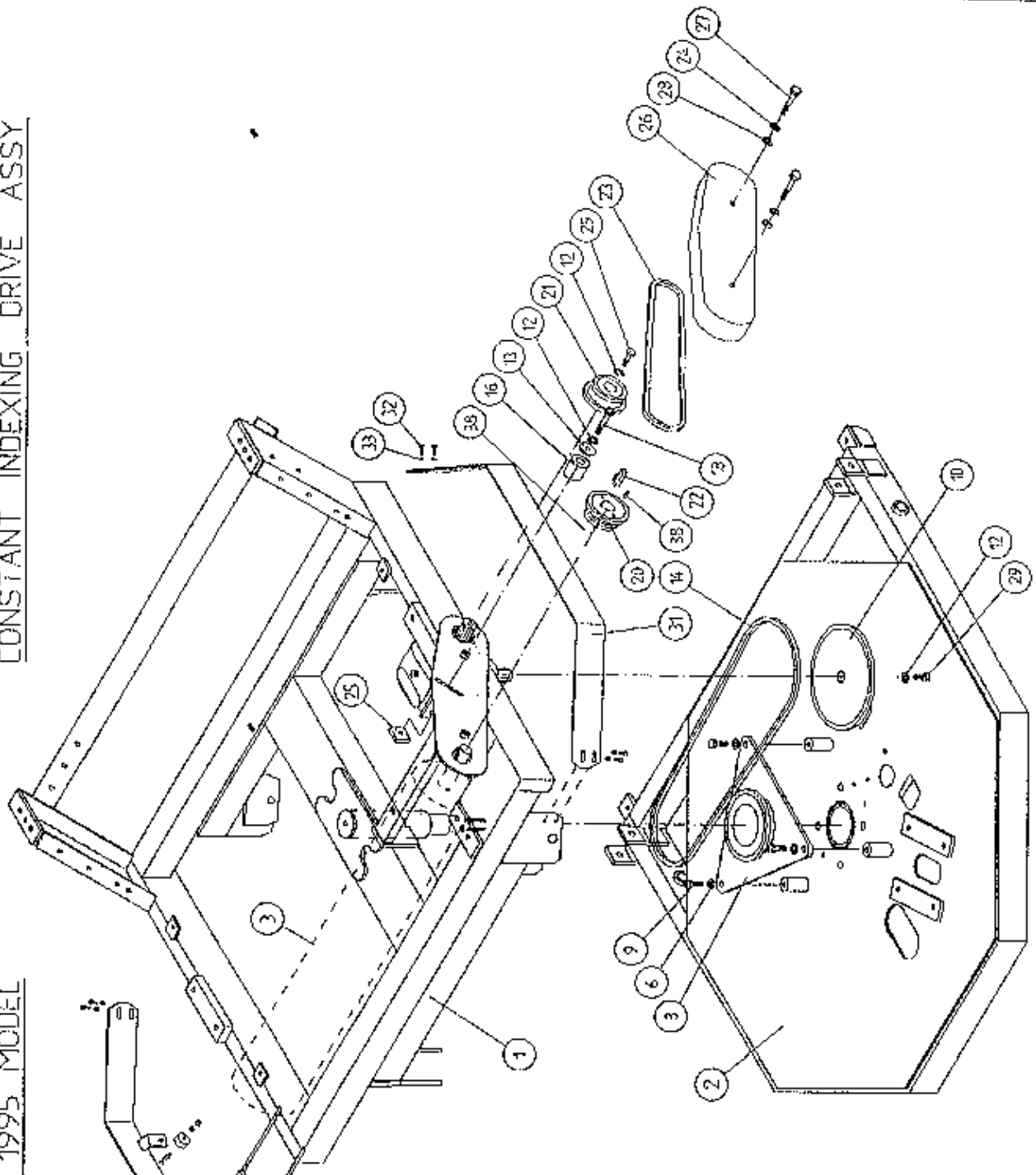

NOTE: ITEMS MARKED WITH * DENOTES ITEMS REQUIRED FOR AUTOMATIC MODELS ONLY.

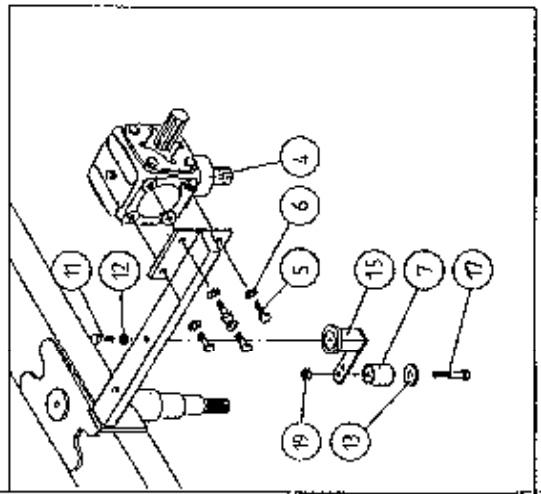

TANCO AUTOWRAP
CONSTANT INDEXING DRIVE ASSEMBLY

PARTS LIST

ITEM NO.	DESCRIPTION	QTY.	PART-NO
1	TURNTABLE ASSY.	1	WD64-TA
2	TIPPING FRAME ASSY.	1	WD64-TF
3	DRIVE ROLLER ASSY.	1	WD658-BRD
4	GEAR BOX	1	Z01-25-300
5	M12 HEX HD SET x 30mm LONG	4	Z26-082S
6	12mm DIA SPRING WASHER	7	Z12-02-12
7	CHAIN TENSIONER	1	WD60-CT
8	CENTRE SPROCKET ASSY 27 TOOTH	1	WD64-CSA
9	M12 HEX HD SET x 25mm LONG	3	Z26-081S
10	36 TOOTH SPROCKET	1	Z06-D64-468
11	M10 HEX HD SET x 25mm LONG	1	Z26-0611S
12	10mm DIA SPRING WASHER	4	Z12-02-10
13	RETAINING COLLAR	3	WD623-071
14	CHAIN 3/4" PITCH X 87 PITCHES	1	Z09-AW-5
15	ROSTA TENSIONING UNIT ARM	1	Z06-454
16	CHAIN TENSIONER	1	WD65-CT
17	M10 HEX HD BOLT x 65MM LONG	1	Z26-0671B
18	M10 HEX HD BOLT x 80MM LONG	1	Z26-0691B
19	M10 LOCKNUT	1	Z23-10
20	SPROCKET DOUBLE SIMPLEX 13T/16T KEYED	1	Z06-D64-1316K
21	SPROCKET DOUBLE SIMPLEX 13T/16T SPLINED	1	Z06-D65-1316S
22	KEY 5/16" x 5/16" x 32mm LONG	1	WD623-K32
23	CHAIN 3/4" PITCH X 62 PITCHES	1	Z09-AW-3
24	1/2" DIA STAR WASHER	2	Z10-01-121
25	LOCKING FLAT	1	WD623-060
26	CHAIN GUARD	1	WD60-CGC
27	M10 HEX HD SET x 70mm LONG	2	Z26-068B
28	10mm DIA FLAT WASHER	2	Z10-02-10
29	M10 HEX HD SET x 30mm LONG	2	Z26-062S
30	GUARD	1	WD64-TG
31	GUARD	1	WD64-020
32	M8 HEX HD SETS X 20MM LONG	8	Z26-020S
33	8MM DIA SPRING WASHER	8	Z12-02-08
34*	MAGNET	2	D6043
35*	M6 CSK HD SET X 35MM LONG	2	Z13-132
36*	6MM DIA FLAT WASHER	2	Z11-02-06
37*	M6 LOCKNUT	2	Z23-06
38	SPIRAL PIN	2	Z03-23-062

* DENOTE ADDITIONAL ITEMS REQUIRED FOR AUTOMATIC MACHINES

TANCO AUTOWRAP 450 S/550 S/550 A MODELS 1995

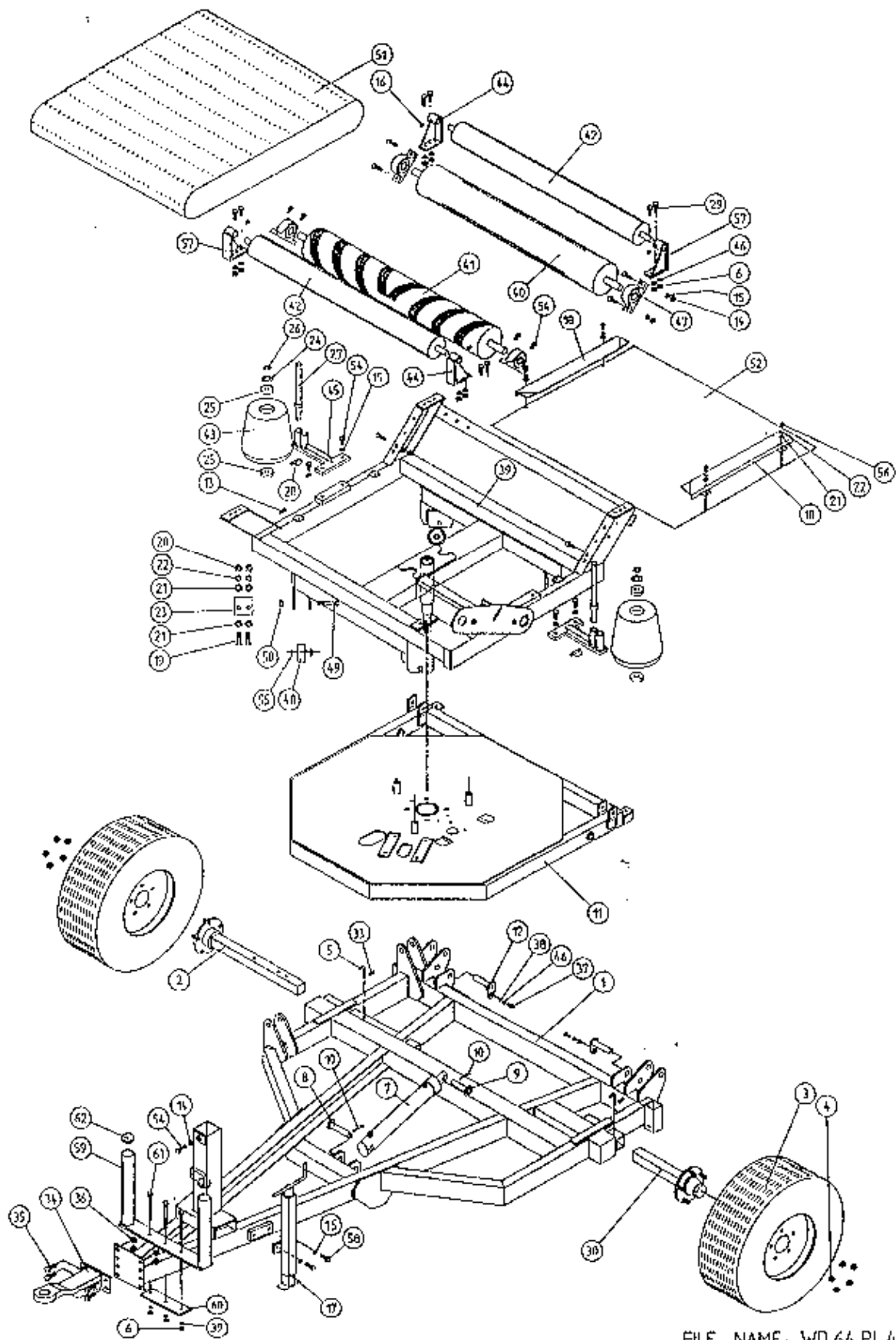

FILE NAME - WD 64 PL 44

WD64-PL7

TANCO AUTOWRAP 450S/550S/550A MODELS (TRAILED) 1995

PARTS LIST

ITEM NO	DESCRIPTION	QTY	PART-NO.
1.	CHASIS ASSY	1	WD60-CHA
2.	STUB AXLE (LONG)	1	Z04-033
3.	WHEELS	2	Z04-03
4.	WHEELS NUTS	10	M22AWNA
5.	BISSSEL PIN	2	Z03-22-AW82
6.	M10 HEX NUT	12	Z18-10
7.	HYD. RAM	1	Z01-01-AR687
8.	RAM. BOTTOM PIVOT PIN	1	Z03-02-330
9.	RAM TOP PIVOT PIN	1	Z03-03-50
10.	2" X 1/4" SPLIT PIN	2	Z03-21-29
11.	TIPPING FRAME ASSY	1	WD64-TF
12.	TIPPING FRAME PIVOT PIN C/W GREASE NIPPLE	2	Z03-01-9055 Z39-60
13.	M10 HEX HD SET X 30MM LONG	4	Z26-0628
14.	M12 HEX NUT	13	Z16-12
15.	12MM DIA SPRING WASHER	12	Z12-02-12
16.	1/8" B.S.P. ST GREASE NIPPLE	4	Z39-60
17.	SCREW JACK ASSEMBLY	1	WD60-JA
18.	BELT GUIDE ASSY	2	WD64-BG
19.	M8 HEX HD SETS X 20MM LONG	8	Z26-0398
20.	M8 HEX NUTS	14	Z18-08
21.	8MM DIA FLAT WASHERS (MUD FLAP)	8	Z11-02-081
22.	8MM DIA SPRING WASHERS	8	Z12-02-08
23.	SCRAPER	2	WD60-708
24.	THRUST WASHER	2	WD60-292
25.	BEARING (25MM I.D.)	4	Z06-AWRB-93
26.	CIRCLIP	2	Z28-525
27.	ROLLER SHAFT ASSEMBLY	2	WD60-RSA
28.	10MM "D" LINC PINS	2	Z38-03
29.	M10 HEX HD SET X 35MM LONG	8	Z26-0638
30.	STUB AXLE (SHORT)	1	Z04-032
33.	4MM "R" CLIP	2	Z36-02
34.	RING HITCH ASSY (LONG)	1	WD65-HIT
35.	M16 HEX HD SET X 45MM LONG	4	Z26-1238
36.	M16 LOCKNUTS	4	Z23-16
37.	M10 HEX HD SET X 25MM LONG	2	Z26-0618
38.	10MM DIA MACHINED FLAT WASHER	2	Z11-02-10
39.	TURN TABLE ASSY	1	WD64-TA
40.	BELT ROLLER ASSY IDLER	1	WD610-BRI
41.	BELT ROLLER ASSY DRIVER	1	WD650-BRD
42.	SMALL ROLLER ASSY	2	WD60-SMR
43.	SIDE ROLLER	2	Z06-AWR
44.	ROLLER MTG BRACKET	2	WD60-TRMBR
45.	END ROLLER MOUNTING BRACKET	2	WD650-ERM
46.	10MM SPRING WASHERS	10	Z12-02-10
47.	1 1/4" PILLOW BLOCK BEARING C/W CAM LOCK COLLAR	4	Z06-485
48.	SUPPORT WHEELS (4" DIA)	4	Z06-466
49.	AXLE ASSY C/W GREASE NIPPLE	4	Z03-22-AW/AX Z39-60
50.	M20 LOCKNUTS	4	Z23-20
51.	1.130MM WIDE X 2475MM LONG X 1/4" FLAT BELT	1	Z05-02A95
52.	TURN TABLE COVER PLATE	1	WD60-093
54.	M12 HEX HD ST X 40MM LONG	14	Z26-0848
55.	SPACER	8	WD60-198
56.	M8 HEX HD SET X 30MM LONG	4	Z26-0418
57.	ROLLER MOUNTING BRACKET	2	WD60-TRMBL
58.	M12 HEX HD SET x 30mm LONG	2	Z26-0828
59.	FILM TRANSPORT BRACKET	1	WD60-FTB1
60.	CLAMPING PLATE	1	WD60-933
61.	M10 HEX HD BOLT x 140mm LONG	3	Z26-07268
62.	PLASTIC CAP	2	Z32-08

**TANCO AUTOWRAP 450S/550S/550A MODEL (TRAILED) 1995
LIFT ARM AND CHASSIS**

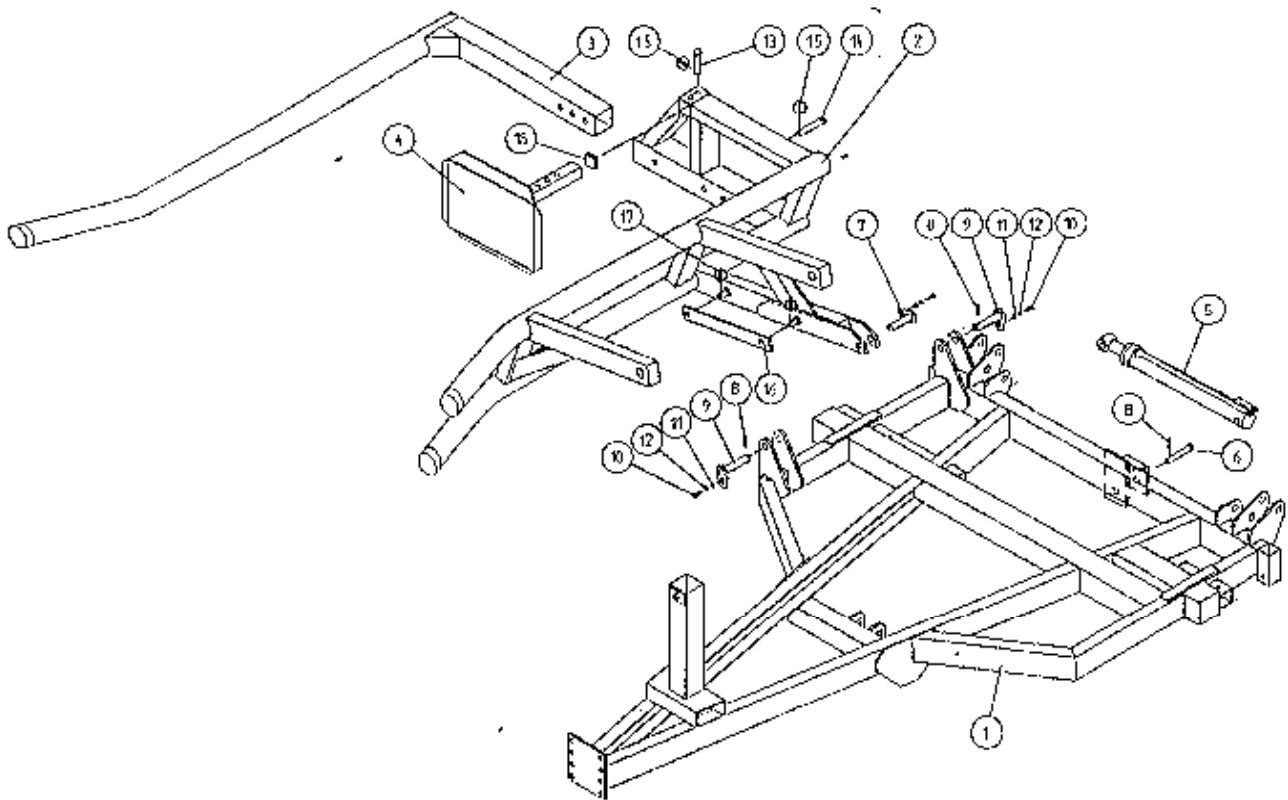

PARTS LIST

ITEM NO.	DESCRIPTION	QTY.	PART-NO.
1.	CHASSIS ASSEMBLY	1	WD60-CHA
2.	LIFT ARM ASSEMBLY	1	WD60-LA
3.	ADJUSTABLE OUTER ARM ASSY	1	WD60-LAAA
4.	ADJUSTABLE BALE STOP	1	WD610-LAS
5.	HYDRAULIC RAM (LIFT ARM)	1	Z01-01-AW
6.	RAM BOTTOM PIVOT PIN	1	Z03-02-330
7.	RAM TOP PIVOT PIN	1	Z03-01-797
8.	2" x 1/4" SPLIT PINS	3	Z03-21-29
9.	LIFT ARM PIVOT C/W GREASE NIPPLE	2	Z03-01-905
10.	M10 HEX HD SET x 25mm LONG (TUFLOCK)	3	Z26-061S
11.	10mm DIA MACHINED FLAT WASHER	3	Z11-02-10
12.	10mm DIA SPRING WASHER	3	Z12-02-10
13.	SPAREX PIN	1	Z03-04-73
14.	SPAREX PIN	1	Z03-04-77
15.	7/16" DIA LINCH PINS	2	Z03-22-06
16.	SAFETY SUPPORT BAR	1	WD60-319
17.	6mm DIA LINCH PIN	2	Z03-22-03
18.	PLASTIC CAP	1	Z32-10

TANCO AUTOWRAP 450S MODEL (TRAILED) 1995
 FILM DISPENSER SYSTEM

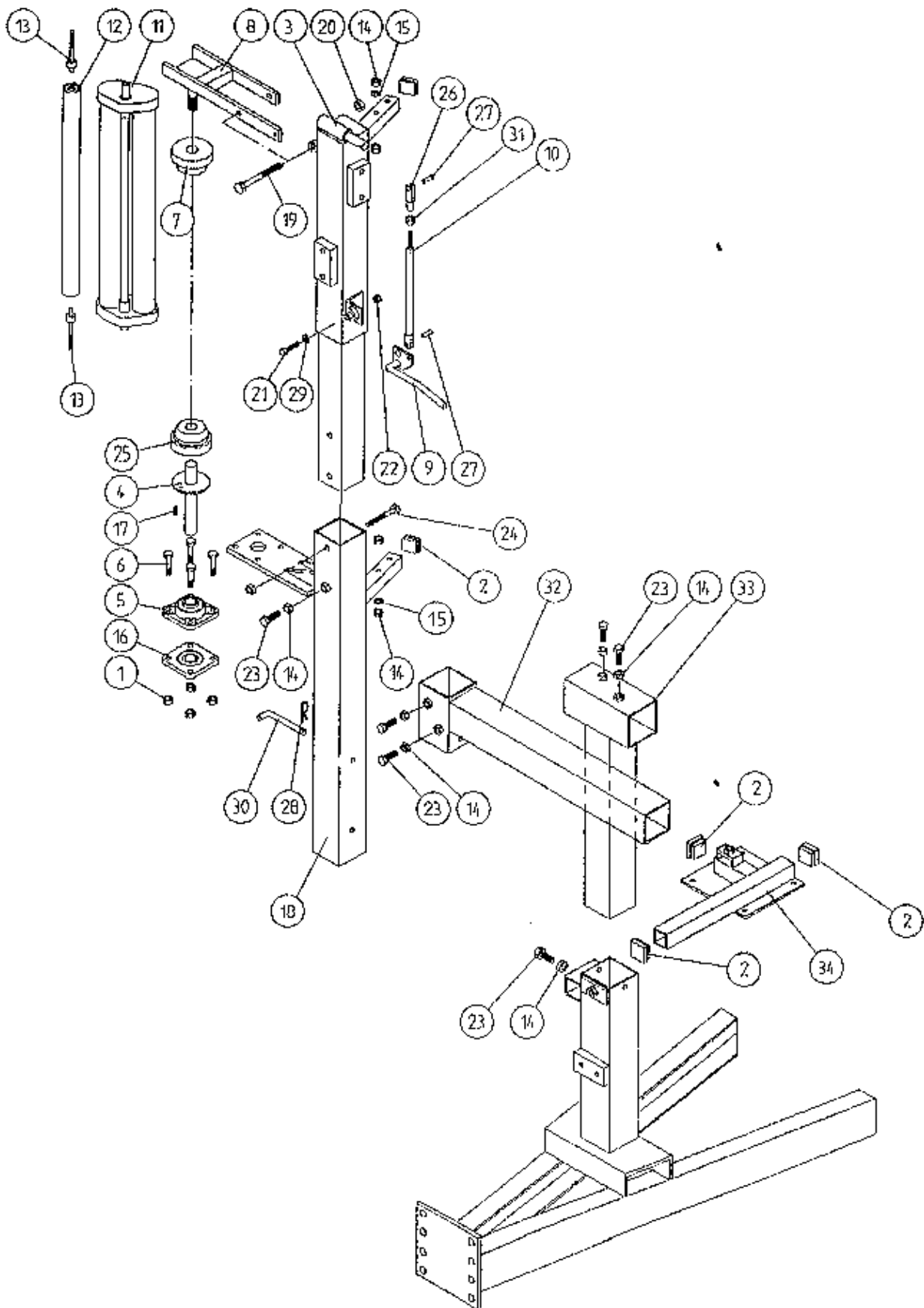

• FILE NAME WT.64 - PL26

TANCO AUTOWRAP 450S MODEL (TRAILED) 1995

FILM DISPENSING SYSTEM

PARTS LIST

ITEM NO.	DESCRIPTION	QTY.	PART-NO
1	M10 LOCKNUTS	4	Z23-10
2	PLASTIC CAPS (TO SUIT 40 X 40 X 3 RHS)	5	Z32-07
3	DISPENSER MOUNTING (UPPER)	1	WD60-DMJII
4	FILM SPOOL ASSEMBLY	1	WD60-SPO
5	1" DIA FLANGE BEARING C/W CAM LOCK	1	Z06-48EC
6	M10 HEX HD. BOLT X 50MM LONG	4	Z26-066B
7	CONE (TOP) C/W BALL BEARINGS	1	Z06-45-01
8	CLAMP ASSEMBLY	1	WD60-DMCA
9	LEVER ASSEMBLY	1	WD60-DMLA
10	LINK ASSEMBLY	1	WD60-DMLK
11*	FILM DISPENSER UNIT MK 6 (70% STRETCH)	1	D613
12	SLAVE ROLLER (SHORT)	1	Z06-SR95-S
13	SLAVE ROLLER PIVOT	2	WD64-SRP
14	M12 HEX NUTS	6	Z18-12
15	12MM DIA SPRING WASHER	2	Z12-02-12
16	VALVE MOUNTING PLATE ASSEMBLY	1	WD65-VMP
17	1/4" DIA TENSION PIN X 3/4" LONG	1	Z03-20-062
18	DISPENSER MOUNTING (LOWER)	1	WD60-DMLII
19	M12 HEX HD BOLT X 130MM LONG	1	Z26-094B
20	M12 LOCKNUT	3	Z23-12
21	M8 HEX HD BOLT X 35MM LONG	1	Z26-042S
22	M8 LOCKNUT	1	Z23-08
23	M12 HEX HD SET X 30MM LONG	2	Z26-082S
24	M12 HEX HD BOLT X 100MM LONG	1	Z26-092B
25	CONE (BOTTOM)	1	Z06-45-02
26	CLEVIS (M10)	1	Z49-335
27	PIN (5/16" DIA) C/W CLIP	2	Z49-337
28	4MM "R" CLIP	1	Z36-02
29	8MM DUA MUD FLAP WASHER	1	Z11-02-081
30	BISSEL PIN X 11.0MM LONG	1	WD60-874
31	5/16" UNF HEX NUT	1	Z15-05
32	1" DIA FLANGE BEARING	1	Z06-48

* NOTE: From Dispenser Serial no. 15370 onwards item no 11 should read
DISPENSER UNIT MK 7 (70% STRETCH) PART NO: D614

TANCO AUTOWRAP 550S/550A MODELS 1995
FILM DISPENSING SYSTEM

PARTS LIST

ITEM NO.	DESCRIPTION	QTY	PART-NO.
1.	M10 LOCKNUTS	4	Z23-10
2.*	PLASTIC CAPS (TO SUIT 40 x 40 x 3 RHS)	2+3	Z32-07
3.	DISPENSER MOUNTING (UPPER)	1	WD60-DMUH
4.	FILM SPOOL ASSEMBLY	1	WD60-SPO
5.	1" DIA FLANGE BEARING C/W CAM LOCK	1	Z06-48EC
6.	M10 HEX HD BOLT x 50mm LONG	4	Z26-066B
7.	CONE (TOP) C/W BALL BEARINGS	1	Z06-45-01
8.	CLAMP ASSEMBLY	1	WD60-DMCA
9.	LEVER ASSEMBLY	1	WD60-DMLA
10.	LINK ASSEMBLY	1	WD60-DMLK
11.*	FILM DISPENSER UNIT MK 8 (70% STRETCH)	1	D615
12.	SLAVE ROLLER LONG	1	Z06-SR95-L
13.	SLAVE ROLLER PIVOT	2	WD64-SRP
14.	M12 HEX NUTS	10	Z18-12
15.	12mm DIA SPRING WASHER	2	Z12-02-12
16.	SLEEVE	1	D52012-95
17.	1/4" DIA TENSION PIN x 3/4" LONG	1	Z03-20-062
18.	DISPENSER MOUNTING (LOWER)	1	WD60-DMLH
19.	M12 HEX HD BOLT x 130mm LONG	1	Z26-094B
20.	M12 LOCKNUT	3	Z23-12
21.	M8 HEX HD BOLT x 35mm LONG	1	Z26-042S
22.	M8 LOCKNUT	1	Z23-08
23.	M12 HEX HD SET x 30mm LONG	6	Z26-082S
24.	M12 HEX HD BOLT x 100mm LONG	1	Z26-092B
25.	CONE (BOTTOM)	1	Z06-45-02
26.	CLEVIS (M10)	1	Z49-335
27.	PIN (5/16" DIA C/W CLIP)	2	Z49-337
28.	M12 HEX HD BOLT x 80mm LONG	1	Z26-0901B
29.	3/4" DIA FLAT WASHER	1	Z10-02-19
30.	FILM PULL DOWN BRACKET ASSY	1	WD65-FPDB
31.	FILM PULL DOWN ARM ASSY	1	WD65-FPDA
32.	RETAINING WASHER	1	WD60-859
33.	ROLLER	1	WD60-866
34.	2" x 1/4" SPLIT PIN	1	Z01-23-29
35.	4mm "R" CLIP	1	Z36-02
36.	BISSEL PIN (110mm LONG)	1	WD60-874
37.	HYDRAULIC RAM	1	Z01-01-AW25
38.	M12 HEX HD SET x 50mm LONG	1	Z26-086S
39.	5/16" UNF HEX NUT	1	Z15-05
40.	1/8" BSP ST. GREASE NIPPLE	1	Z39-60
41.	M16 LOCKNUT	1	Z23-16
42.	1" GE PLASTIC CAP	2	Z32-14
43.	DISPENSER MAST HORIZONTAL SOCKET ASSY	1	WD65-DHS
44.	DISPENSER MAST VERTICAL SOCKET ASSY	1	WD65-DVS
45.	DISPENSER MAST HORIZONTAL SOCKET ASSY	1	WD65-DHS
46.	4mm "R" CLIPS	1	Z36-02
47.	1" DIA FLANGE BEARING	1	Z06-48
48.*	VALVE MOUNTING PLATE ASSEMBLY	1	WD65-VMP

* DENOTES ADDITIONAL ITEMS REQUIRED FOR 550S MODELS

* NOTE: From Dispenser Serial no. 15370 onwards item no 11 should read
FILM DISPENSER UNIT MK 9 (70% STRETCH) PART NO: D616

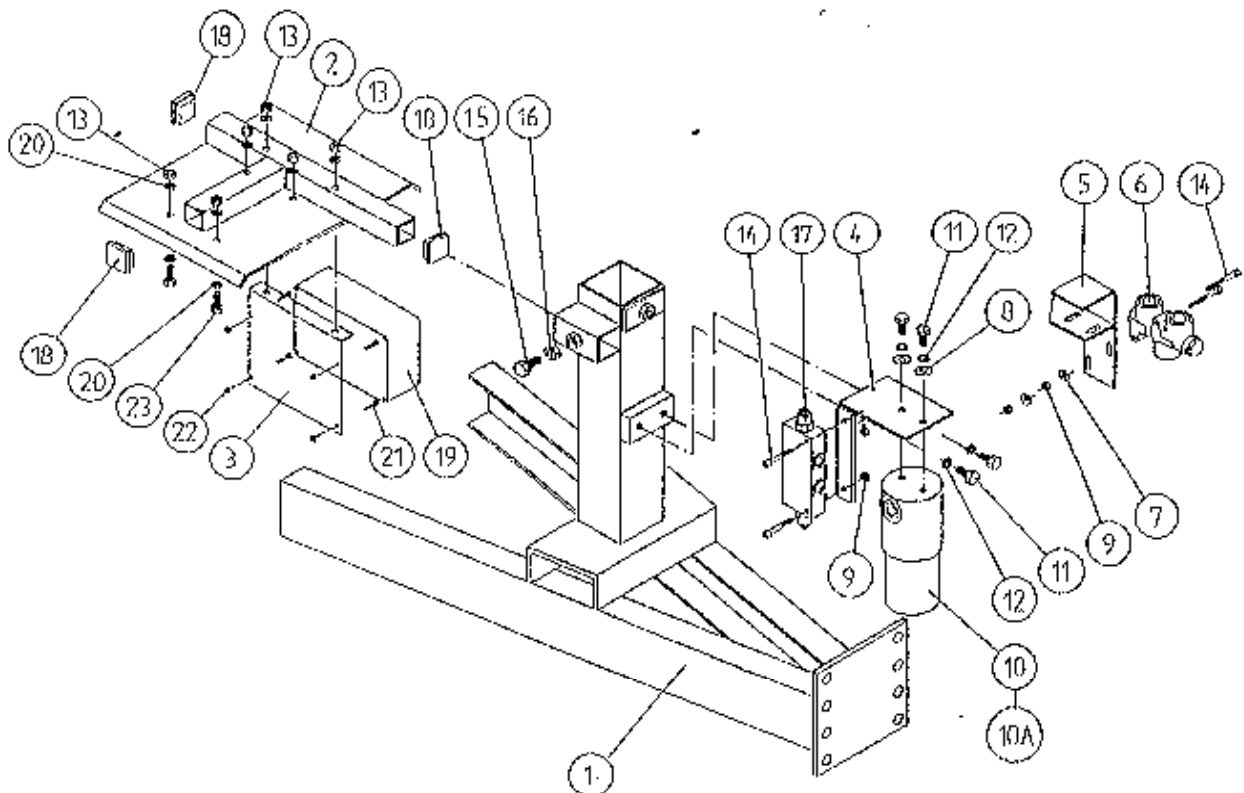
TANCO AUTOWRAP 550A MODEL (1995)VALVE/JUNCTION BOX/FILTER & DIVERTER VALVE MOUNTING
BRACKET ASSEMBLYPARTS LIST

ITEM NO	DESCRIPTION	QTY	PART-NO.
1.	CHASSIS ASSY	1	
2.	3 BANK VALVE MOUNTING BRACKET ASSY	1	WD610-VMP
3.	JUNCTION BOX MOUNTING PLATE	1	WD612-04
4.	OIL FILTER/OVER-CENTRE-VALVE MOUNTING BRACKET	1	WD610-FVB
5.	FLOW DIVIDER MOUNTING BRACKET	1	WD65-FDM
6.	FLOW DIVIDER	1	Z01-03-10-A6
7.	6MM DIA MUD FLAP WASHER	2	Z11-02-061
8.	8MM DIA MUD FLAP WASEHR	2	Z11-02-081
9.	M6 LOCKNUT (NYLOCK)	4	Z23-06
10.	OIL FILTER	1	Z01-24-08
10A.	OIL FILTER ELEMENT	1	Z01-24-08E
11.	M8 HEX HD SET x 25mm	4	Z26-040S
12.	8mm DIA SPRING WASHER	4	Z12-02-08
13.	M8 LOCKNUTS	6	Z23-08
14.	M6 ALLEN HD SOCKET SCREW x 45mm	4	Z13-020-50
15.	M12 HEX HD SET x 30mm	1	Z26-082S
16.	M12 HEX NUT	1	Z18-12
17.	OVER-CENTRE VALVE	1	Z01-03-10-A8
18.	PLASTIC CAP TO SUIT 40 x 40 RHS	3	Z40-07
19.	JUNCTION BOX	1	ZDG-JB2
20.	8mm DIA FLAT WASHER	12	Z10-02-08
21.	M4 ALLEN HD SOCKET SCREW x 16mm	4	Z26-006
22.	M4 LOCKNUT	4	Z23-04
23.	M8 HEX HD SET x 20mm	6	Z26-039S

**TANCO AUTOWRAP
CUT AND START UNIT (1995)
PARTS LIST**

ITEM NO	DESCRIPTION	QTY	PART-NO.
1.	MAIN MOUNTING FRAME ASSY	1	WD605-MF1
2.	LATCH ASSY.	1	WD605-LA
3.	PUSH PLATE / POINTER ASSY.	1	WD605-PPP
4.	GUIDE ASSY	1	WD605-GD1
5.	PLUNGER ASSY	1	WD605-PL1
6.	GAS SPRING	1	Z07-47
7.	GAS SPRING MOUNTING BRACKET	1	WD605-GSM
8.	WARNER LINEAR ACTUATOR D11 10B5 08	1	ZD605-510
9.	"U" BOLT	1	WD605-45
10.	SPACER 1" X OD X 1/2" ID X 6mm LONG	2	WD605-65
11.	SLEEVE 1/2" DIA O.D. X 13/32" DIA I.D.	1	WD605-47
12.	M8 HEX HD SET X 35mm LONG	1	Z26-042S
13.	TRIGGER ASSEMBLY	1	WD605-TRG
14.	COLLAR 1" DIA BRIGHT RD. X 41.5mm LONG	1	WD605-51
15.	SPACER	1	WD605-100
16.	BLADE GUARD/MOUNTING BRACKET	1	WD605-105
17.	M12 HEX HD BOLT X 80mm LONG	2	Z26-0901B
18.	BISSEL PIN	1	Z03-22-AW100
19.	4mm "R" CLIP	1	Z36-02
20.	SPRING 16mm O.D X 1.5mm WIRE X 48mm LONG	1	Z07-34
21.	OILITE OIL RETAINING BUSH 1 1/8" O.D.	3	Z06-105
22.	1 1/2" X 1/4" DIA TENSION PIN	1	Z03-20-07
23.	M12 LOCKNUTS	2	Z23-12
24.	M12 HEX HD BOLT X 65mm	1	Z26-0882B
25.	M8 GRUB SCREW	1	Z28-008
26.	M8 HEX HD SET X 25mm	3	Z26-040S
27.	M12 BINX LOCKNUT	4	Z23-12BX
28.	M8 LOCKNUT	8	Z18-08
29.	M6 LOCKNUT (NYLOCK)	2	Z23-06
30.	10mm DIA FLAT WASHER	10	Z11-02-10
31.	8mm DIA FLAT WASHER	5	Z11-02-08
32.	6mm DIA FLAT WASHER	2	Z11-02-06
33.	3mm DIA SPLIT PIN	2	Z03-21-02
34.	BLADE	1	WD605-104
35.	MAIN GUARD	1	WD605-MG
36.	M8 HEX HD SET X 20mm LONG	2	Z26-039S
37.	8mm DIA SPRING WASHER	9	Z12-02-08
38.	EDGING STRIP	1	Z44-12
39.	M10 HEX HDSET X 20mm	2	Z26-060S
40.	8mm DIA FLAT WASHER 1" O.D.	4	Z11-02-081
41.	PACKER	1	WD605-133
42.	M8 X 40 COUNTER SUNK BOLT	2	Z13-5-08X40
43.	M12 HEX HD BOLT X 50mm LONG	1	Z26-086B
44.	M10 LOCKNUT	1	Z23-10

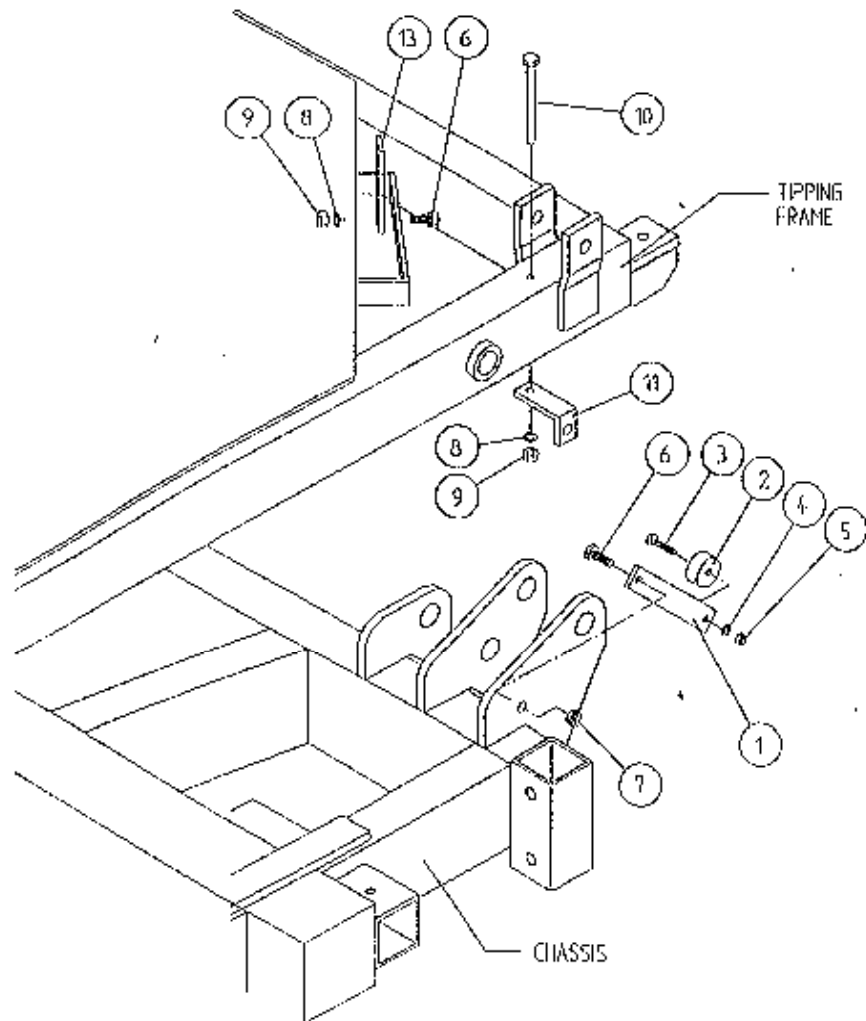
TANCO AUTOWRAP CUT AND START UNIT 1995SENSOR AND MAGNET MOUNTING BRACKETSPARTS LIST

ITEM NO.	DESCRIPTION	QTY.	PART-NO.
1.	MAGNET MOUNTING BRACKET	1	WD605-165
2.	MAGNET	1	D6043
3.	M6 HEX HD SET x 30mm LONG	1	Z26-022S
4.	6mm DIA FLAT WASHER	1	Z11-02-06
5.	M6 LOCKNUT	1	Z23-06
6.	M8 HEX HD SET x 25mm LONG	2	Z26-040S
7.	M8 LOCKNUT (NYLOCK)	1	Z23-08
8.	8mm DIA SPRING WASHER	2	Z12-02-08
9.	M8 HEX NUT	2	Z18-08
10.	M8 HEX HD SET x 100mm LONG	1	Z26-057S
11.	SENSOR MOUNTING BRACKET	1	WD605-58
12.	SENSOR MOUNTING FLAT	1	WD605-164

TANCO AUTOWRAP CUT AND START UNIT (1995)
SLIP RING ASSY.

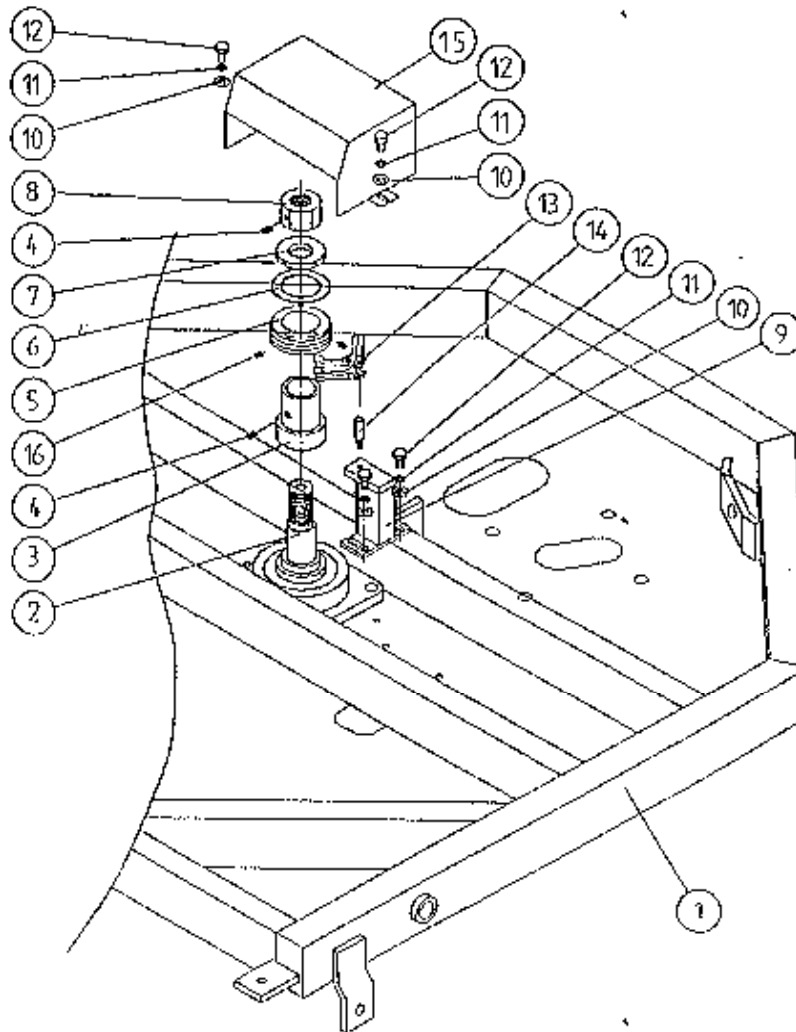

PARTS LIST

ITEM NO.	DESCRIPTION	QTY.	PART-NO.
1.	UNDERSIDE OF TIPPING FRAME	1	WD64-TF
2.	TURNTABLE CENTRE SHAFT	1	WD64-002
3.	SLIP RING MOUNTING SLEEVE	1	WD605-161
4.	M8 GRUB SCREW x 6 mm LONG	2	Z28-007
5.	SLIP RING ASSY.	1	ZD605-308
6.	INSULATING RING	1	ZD605-350
7.	LOCKING COLLAR	1	WD60-770
8.	1 1/4" UNC HEX NUT	1	Z18-300
9.	SLIP RING MOUNTING BRACKET ASSY	1	WD605-BMB
10.	10mm DIA FLAT WASHER 1" O.D.	4	Z11-02-101
11.	10mm SPRING WASHER	4	Z12-02-10
12.	M10 HEX HD SET x 20mm	4	Z26-060S
13.	BRUSHES	2	ZD605-306
14.	INSULATOR SLEEVE	1	ZD605-302
15.	SLIP RING GUARD ASSY	1	WD605-SRG
16.	M5 GRUB SCREW	2	Z28-005

TANCO AUTOWRAP
CUT AND START UNIT (1994)
MAIN ASSEMBLY

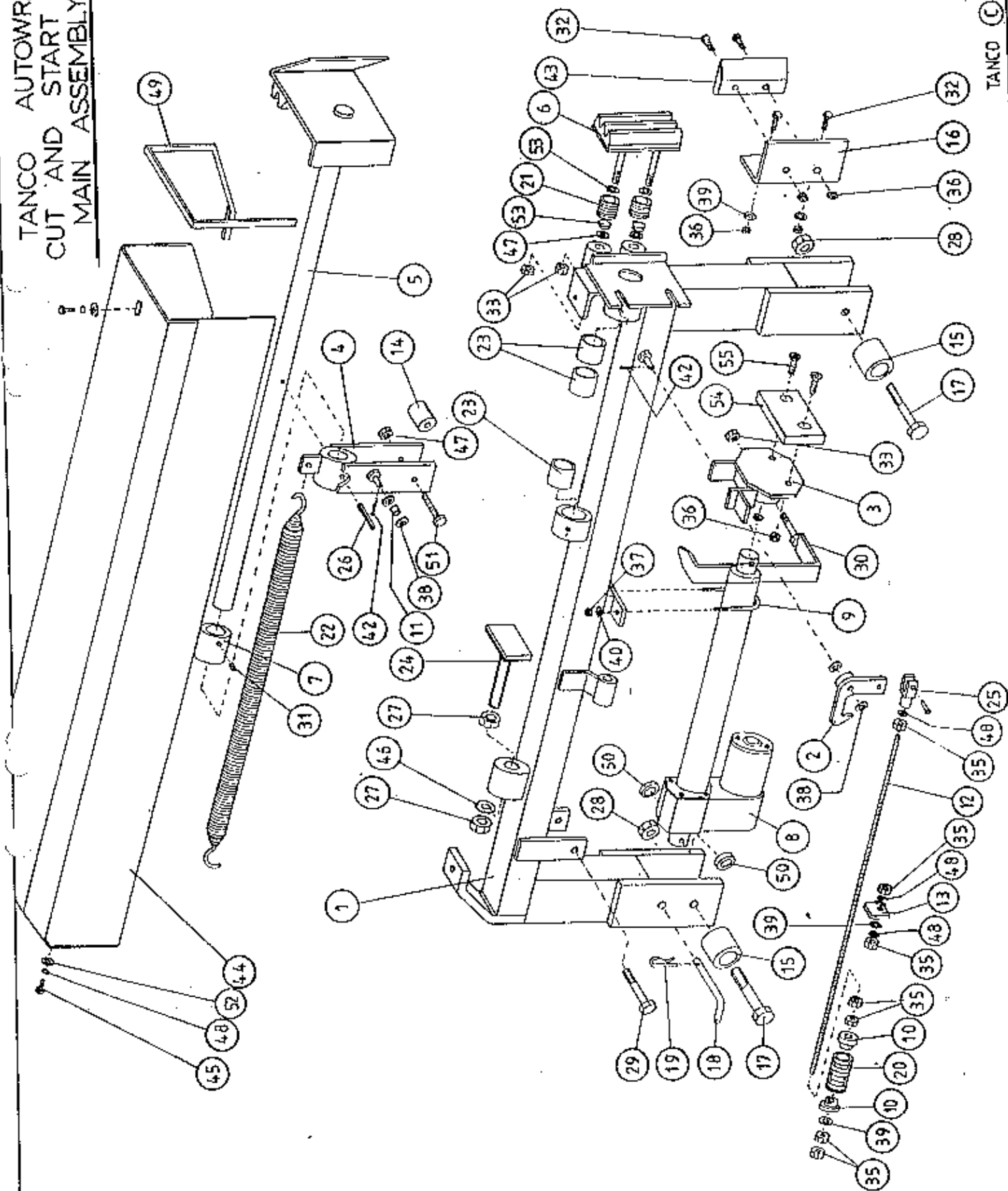

AUTOWRAP

TANCO AUTOWRAP
CUT AND START UNIT (1994)
PARTS LIST

ITEM NO	DESCRIPTION	QTY	PART-NO.
1.	MAIN MOUNTING FRAME ASSY	1	WD605-MF
2.	LATCH ASSY.	1	WD605-LA
3.	PUSH PLATE ASSY.	1	WD605-PP
4.	GUIDE ASSY	1	WD605-GD
5.	PLUNGER ASSY	1	WD605-PL
6.	FILM GRIPPER ASSY	1	WD605-FG
7.	PLUNGER END CAP	1	WD605-90
8.	WARNER LINEAR ACTUATOR D11 10B5 08	1	ZD605-510
9.	"U" BOLT	1	WD605-45
10.	STEPPED COLLAR	2	WD605-46
11.	SLEEVE 1/2" DIA O.D. X 13/32" DIA I.D.	1	WD605-47
12.	THREADED ROUND 5/16" UNF	1	WD605-48
13.	TRIGGER	1	WD605-50
14.	COLLAR 1" DIA BRIGHT RD. X 41.5MM LONG	1	WD605-51
15.	SPACER	1	WD605-100
16.	BLADE GUARD/MOUNTING BRACKET	1	WD605-105
17.	M12 HEX HD BOLT X 80MM LONG	2	Z26-0901B
18.	BISSEL PIN	1	Z03-22-AW100
19.	4MM "R" CLIP	1	Z36-02
20.	SPRING 16MM O.D. X 1.5MM WIRE X 48MM LONG	1	Z07-34
21.	SPRING 1.09" O.D. X 0.092" WIRE X 1.54" LONG	2	Z07-44
22.	SPRING 1.125 O.D. X 0.125" WIRE X 330MM	1	Z07-46
23.	OILITE OIL RETAINING BUSH 1 1/8" O.D. X 3/4" X 1" L.	3	Z06-105
24.	RUBBER BUFFER ASSY.	1	WD605-BA
25.	CLEVIS C/W PIN	1	Z49-33
26.	1 1/2" X 1/4" DIA TENSION PIN	1	Z03-20-07
27.	M16 HEX NUTS	2	Z18-16
28.	M12 LOCKNUTS	2	Z23-12
29.	M12 HEX HD BOLT X 65MM	1	Z26-0882B
30.	INDICATOR ASSY	1	WD605-PR
31.	M8 GRUB SCREW	1	Z28-008
32.	M8 HEX HD SET X 25MM	4	Z26-040S
33.	M12 BINX LOCKNUT	4	Z23-12BX
35.	5/16" UNF HEX NUT	7	Z15-05
36.	M8 LOCKNUT	9	Z18-08
37.	M6 LOCKNUT (NYLOCK)	2	Z23-06
38.	10MM DIA FLAT WASHER	10	Z11-02-10
39.	8MM DIA FLAT WASHER	5	Z11-02-08
40.	6MM DIA FLAT WASHER	2	Z11-02-06
42.	3MM DIA SPLIT PIN	2	Z03-21-02
43.	BLADE	1	WD605-104
44.	MAIN GUARD	1	WD605-MG
45.	M8 HEX HD SET X 20MM LONG	2	Z26-039S
46.	10MM DIA SPRING WASHER	2	Z12-02-10
47.	12MM DIA FLAT WASHER	2	Z11-02-12
48.	8M DIA SPRING WASHER	9	Z12-02-08
49.	EDGING STRIP	1	Z44-12
50.	SPACER 1" O.D. X 1/2" I.D. X 6MM LONG	2	WD605-65

FAULT FINDING

PROBLEMS.

- | | |
|--|--|
| 1. Drive Roller and Bale belt not driving | Check and replace shear
Pin in sprocket on
drive roller. |
| 2. Film Broaking | Wash off dispenser and slave
rollers Change roll of film.
Use recommended films only. |
| 3. Film not wrapping evenly on | Adjust film mast so centre of film
roll is aligned with centre of bale |
| 4. Film Tearing on Ramp. | Check for sharp edges and remove. |
| 5. Bale Skidding on Ramp. | Fit Messian Bag or piece of carpet to
Ramp. |
| 6. Film Dispenser not
Pre-Stretching Film. | Check that both Rollers
turn when one is turned by hand. If
not, fit new gears or replace unit. |
| 7. Tyres coming off 4" platform
Support Wheels. | Replace Wheels - Reduce
speed below 30 r.p.m. - Do not
grease path of wheels on platform.
Check that bale does not get trapped
between arms and turntable
when being loaded.

If this happens lower arm
and start again. |

8. MAIN BELT MOVING SIDWAYS

- (i) Ensure vertical rollers (plastic) are in tight on the bale. Remember that the bale will reduce in size during wrapping and, on the round bales in particular, the corners will become rounded so that the bale will tend to move sideways due to centrifugal forces. Now, if the plastic rollers are too far apart, the bale will move against one of the plastic rollers causing the belt to move in the opposite direction. Always adjust the vertical plastic rollers so that they keep the bale central on the belt.
- (ii) Adjust bale stop on lift arm so that bale is loaded centrally onto platform.
- (iii) Check that bale belt is fitted so arrow points in direction of travel.
- (iv) Check that both 8" rollers underneath the bale belt are parallel to each other. Remember the golden rule - a belt will always move up a slope. So, if the belt continually moves to one side, adjust idler roller to a narrower setting on the opposite side to which the belt travels.
- (v) Check that gripface strips are securely fixed to the roller and have not moved out of alignment.
- (vi) Check that it is the same measurement each side by running a string around the belt and measuring it. If one side is longer than the other replace the belt.

EC DECLARATION OF CONFORMITY

according to Directives 89/392/336/EEC
as amended

Manufacturer

TANCO ENGINEERING CO. LTD.
BAGENALSTOWN
CO. CARLOW
IRELAND

Certifies that the following product:

AUTOWRAP

MODEL

450S / 550S / 550A

SERIAL No.

D2000 - D3000

To which this declaration relates, corresponds to the essential requirements of the Directive 89/392/336/EEC as amended.

To conform to these essential health and safety requirements, the provisions of the following harmonized standards were particularly considered:

EN 292 - 1,2 , EN 294 , EN 1152 , prEN 703 , prEN 811 , prEN 1553 , prEN 982.

DATE 01-01-96

SIGNATURE

Alfred A Cox
ALFRED A. COX, TECHNICAL DIRECTOR