

TANCO AUTOWRAP
400A/500A MODEL 1994
OPERATORS HANDBOOK
AND
PARTS LIST
WD65-400-A / 500-A-M0594

INDEX**400A / 500A MODEL****PAGE NO.**

SAFETY INSTRUCTIONS	1/2
TECHNICAL SPECIFICATIONS	3
PRE DELIVERY INSTRUCTIONS	4/5/6
TRANSPORT INSTRUCTIONS	7
MACHINE IDENTIFICATION	7
PREPARATION OF A NEW MACHINE	8
HYDRAULIC CONNECTIONS	8
JUNCTION BOX & CONTROLLER FOR 3 BANK VALVE	9
AUTOMATIC BALE WRAP CONTROLLER	10
OPERATOR ACCESSIBLE MONITOR PROGRAMMES	11/12/13
MODE OF OPERATION	14
OPERATING INSTRUCTIONS	15
WARNING; LIFT ARM	16
FILM OVERLAP SYSTEM	17
SERVICE AND MAINTENANCE	18/19
FILM THREADING DIAGRAM	20
PRIMARY CHAIN DRIVE TENSIONING SYSTEM	21
DRIVE BELT TENSIONING SYSTEM	22
FILM ADAPTOR OPERATING INSTRUCTIONS	23
ELECTRICAL COMPONENTS ILLUSTRATED	24
PARTS LIST FOR ABOVE	24:1
HYDRAULIC CIRCUIT DIAGRAM 400 A MODEL (TRAILED)	25
HYDRAULIC CIRCUIT DIAGRAM 500 A MODEL (TRAILED)	26
HYDRAULIC COMPONENTS ILLUSTRATED 400 A MODEL (TRAILED)	27
PARTS LIST FOR ABOVE	27:1
HYDRAULIC COMPONENTS ILLUSTRATED 500 A MODEL (TRAILED)	28
PARTS LIST FOR ABOVE	28:1
FITTING 2 WAY SOLENOID VALVE	29
CONSTANT INDEXING DRIVE ASSY ILLUSTRATED	30
PARTS LIST FOR ABOVE	30:1
AUTOWRAP ILLUSTRATED (400A/500A MODEL)	31
PARTS LIST FOR ABOVE	31:1
AUTOWRAP ILLUSTRATED (400A/500A MODEL)	32
PARTS LIST FOR ABOVE	32:1
HYDRAULIC MOTOR DRIVE	33
PARTS LIST FOR ABOVE	33:1
LIFT ARM ASSEMBLY ILLUSTRATED (400A/500A MODEL)	34
PARTS LIST FOR ABOVE	34:1
FILM DISPENSING SYSTEM ILLUSTRATED (400A MODEL)	35
PARTS LIST FOR ABOVE	35:1
FILM DISPENSING SYSTEM ILLUSTRATED (500A MODEL)	36
PARTS LIST FOR ABOVE	36:1
VALVE/JUNCTION BOX/FILTER & DIVERTER VALVE MOUNTING BRACKET ASSEMBLY	37
PARTS LIST FOR ABOVE	37:1
FAULT FINDING SUMMARY	38/39

INDEX**400A/500A****PAGE**

CUT AND START UNIT ILLUSTRATED _____	40
PARTS LIST FOR ABOVE _____	40:1
CUT AND START UNIT ILLUSTRATED _____	41
PARTS LIST FOR ABOVE _____	41:1
CUT AND START MOUNTING FRAME ILLUSTRATED _____	42
PARTS LIST FOR ABOVE _____	42:1
SLIP RING ASSY ILLUSTRATED _____	43
PARTS LIST FOR ABOVE _____	43:1
SENSOR MAGNET MOUNTING BRACKETS ILLUSTRATED _____	44
PARTS LIST FOR ABOVE _____	44:1
CUT AND START FAULT FINDING SUMMARY _____	45/46/47

GENERAL SAFETY INSTRUCTIONS.

Before operating, adjusting or servicing the machine it is important that these instructions are carefully read by those directly concerned.

Whilst every care has been taken in the design of this machine there remains a certain amount of risk to Personnel whilst the machine is in use. It is strongly recommended that the user/operator takes all possible precautions to ensure both his own safety and that of others while the Autowrap is operating. The area around the machine should be kept clear at all times and only the operator should be allowed near the machine when working.

The Autowrap is designed and sold for agricultural purposes and as such complies with the definition as laid down for an Agricultural Trailed Appliance.

Under this definition the machine is not fitted with brakes or lights. IT SHOULD NOT UNDER ANY CIRCUMSTANCES BE TOWED ON THE HIGHWAY AT SPEEDS IN EXCESS OF 20 m.p.h. (30 km/h).

If the machine is to be towed on the highway out of daylight hours then a suitable lighting board with indicators, stop lights and rear lights should be fixed to the rear of the machine before proceeding.

Bales should be loaded carefully on to the turntable and not dropped from a height.

Owners and operators are advised to contact their dealer regarding any field or service problems.

SPECIAL SAFETY INSTRUCTIONS

1. Stop engine of tractor before working on machine.
2. Put a suitable prop under raised platform before working in this area.
3. Always raise Lift Arm and fit safety prop before transporting machine on public roads.
4. Lift Arms should always be lowered before operating turntable.
5. Ensure platform rollers are parallel to Lift Arm before arm is raised.

OPERATING SAFETY INSTRUCTIONS

1. Operators should have their hands on the controls at all times when the machine is use.
2. Autowrap control unit and lever controls must remain in the tractor cab at all times. The operator must at no time leave the tractor cab when the machine is in motion.
3. Keep onlookers clear of machine at all times. Danger zone is 5 metres.
4. Beware of rotating turntable and all moving parts.
5. If not operated correctly the bale could fly off the turntable. The end support rollers must always be fitted. Do not exceed recommended turntable speed of 25 r.p.m. Mis-shapen bales combined with excessive turntable speeds can be dangerous.
6. Care must be taken when tipping bales from machine on sloping ground and during subsequent handling to ensure that they do not roll, thus causing hazard.

THINK OF YOUR PERSONAL SAFETY AND THAT OF OTHERS AT ALL TIMES.

TECHNICAL SPECIFICATIONS

		400A 500A Model (Trailed)
Dimensions		
Total Length - Excluding Bale Ramp	...	350cm
Width - excluding lift arm	...	221cm
Width - lift arm fully raised	...	243cm
Width - lift arm lowered	...	380cm
Height to top of side (bale guide) rollers	...	110cm
Height to top of lift	...	242cm
Weight		
With lift arm	...	1080kgs
Without lift arm	...	960kgs
Wheels		
Size	...	10-80.12
Pressure	...	42 p.s.i.
Lift arm capacity - Axle extended normally	...	750kgs
Lift arm capacity - Axle extended fully	...	900kgs
Speed of turntable	...	25 rev/min*
Oil requirement	...	23litres/min (165 kp cm ²)
Attachment to tractor	...	T r a c t o r Hitch
Bale sizes	...	120 x 120 cm up to 120 cm x 153 cm max 900 kgs
Film (Width of Roll)	...	500mm - 400 Model & 750mm on 500 Model.

* The speed of rotation can be varied to suit various conditions but on no account should it exceed 25 r.p.m. (Speeds in excess of 25 r.p.m. will void warranty).

PRE DELIVERY INSTRUCTIONS

IMPORTANT: DO NOT ATTEMPT TO OPERATE UNTIL THE FOLLOWING INSTRUCTIONS ARE PERFORMED OTHERWISE SERIOUS DAMAGE COULD BE CAUSED.

1. MACHINE ASSEMBLY

For ease of transportation some items are removed from their positions and stored elsewhere on the machine. The control box, film dispenser and cut and start unit are stored under the bale belt. Also stored under belt on remote control machines are the infra red receiver and sender units and warning beacon. The film mast is attached to the front of the machine. On round bale machines only, the top rollers c/w mounting brackets and the plastic end rollers are mounted on temporary brackets beside the bale belt, also the main guard may be dropped from its mounting position on the machine chassis. Road wheels, bale lift arm and bale ramp are transported separately. Remove the above items and assemble as detailed in parts list section of this manual taking particular note of the following points.

(i) DISPENSER MAST

Insert lift mast into socket towards front of machine. Ensure film pull down ram is faced towards the machine. Attach the pull down arm hydraulic ram. Attach the film dispenser to the mast ensuring that the end marked top is faced up. On remote control machines attach the infra red receiver and warning beacon to top of mast. The film mast height is adjustable. Its height is dependant on bale size and type and is set in the field. It should be set so that centre line of film is in line with centre of bale. See Fig. 1

(ii) CUT & START

Attach Cut & Start unit to mounting frame on the left hand side of the machine. It is possible to move the unit along the mounting and fix it to any of three holes. On all round bale wrapping machines the unit is fixed to the centre hole on the mounting frame. Connect electrical supply to unit ensuring that wiring is secure. The cable is stored on the turntable frame near the Cut & Start mounting.

(iii) BALE LIFT ARM

Assemble bale lift arm and attach to mounting points on right hand side of main chassis. Attach hydraulic ram to lift arm; grease pivot pins.

(iv) TOP ROLLERS AND PLASTIC END ROLLERS

Place plastic end rollers in sockets on the back and front of the turntable. On round bale machines only, attach top rollers and mounting brackets to each side of the machine.

(v) MAIN GUARD (round bale machines only)

Bolt main guard onto its four mounting points.

(vi) ROAD WHEELS (trailed machines only)

Attach road wheels ensuring that nuts are tight and tyre pressure is 50 p.s.i.

(vii) BALE RAMP OR MAT

Attach bale ramp or mat to rear of chassis. Note Round bale trailed machines have bale ramps all other machines have bale mats.

CHECKS TO BE PERFORMED

1. Check that all bolts and nuts are tight.
2. That all lubrication points are greased.
3. Check that all guards are in place.
4. Check all operating and safety stickers are in place.

2. OPERATIONAL TEST

When all above assembly and checks have been carried out the operation of the machine should be checked as follows:

NOTE: IF YOU ARE NOT TOTALLY FAMILIAR WITH THE OPERATION OF THE TANCO CONTROL SYSTEM READ THIS MANUAL IN FULL BEFORE PROCEEDING WITH OPERATIONAL TEST.

1. Attach machine to tractor.
2. Connect hydraulic hoses to D/A service on tractor.
3. Fit controller box inside cab.
4. Connect control box to machine and connect power cable direct to tractor battery. It is important that the leads are connected with the correct polarity.
5. Fit cable control actuator socket to convenient position in cab and locate actuators in socket.
6. Lock hydraulic lever in tractor so that oil is flowing through system.
7. Check function by operating control levers.
 - (a) Lift arm up and lift arm down. NOTE ensure lift arm is down before moving to (b).
 - (b) Turntable rotation forward and reverse.
 - (c) Tip up and down checking hoses are o.k.
8. Switch controller on.
9. Switch controller to manual operating mode by operating toggle switch.
10. Check Cut & Start plunger out and in.
11. Switch machine to AUTO mode then run through the Wrapping cycle. See operating instruction section of this manual on how the machine should perform, and if any function fails to operate correctly consult fault finding section of the operators manual.

3. CUSTOMER CHECKS

Before despatching consult customer on the following points:

1. That the machine model suits his requirements.
2. If machine is to be operated on a tractor with a closed centre hydraulic system then a closed centre valve is required, see separate instructions.
3. That the tow hitch type is compatible with the tractor. Three different hitch types are available.

TRANSPORT INSTRUCTIONS

1. Never use straps around the machine when lifting. Use only the following lifting points :- 3pt. Linkage frame and two sockets on each side of the main frame at rear.
2. When transporting machine on tractor three point Linkage the bale loading arm should be in the fully raised position and the safety prop fitted .

MACHINE IDENTIFICATION

The Serial Number plate is located on 3pt. Linkage frame.

Always refer to this number when ordering parts.

The Spare parts catalogue number and description should be used. The reference numbers are used to help identifying the spare part.

For your records write Serial number here.

Serial Number. _____

PREPARATION OF A NEW MACHINE

1. Check height of film mast to ensure that centre line of film spool is level with the centre line of the bale on the turntable. This will alter with different bale diameters. If this alignment is not correct more film than necessary will be used. See Fig 1. Page 15.
2. When connected to John Deere* tractor the valve must be converted to closed centre. See Page 18.

HYDRAULIC CONNECTIONS

Connect the feed and return hoses from the Autowrap valve to the tractor's double-acting facility.

NOTE: The return hose is fitted with a non-return valve to protect the Autowrap from damage in the event of incorrect connection to tractor hydraulics.

NOTE* To ensure maximum efficiency and length of life of hydraulic components this machine requires a clean supply of hydraulic oil. IT IS RECOMMENDED THAT THE TRACTOR HYDRAULIC FILTER ELEMENT BE REPLACED AND THEREAFTER MAINTAINED IN ACCORDANCE WITH THE MANUFACTURERS RECOMMENDATIONS.

**TANCO AUTOWRAP 200AL/400A/500A/1050A MODELS
JUNCTION AND CONTROLLER FOR 3 BANK VALVE**

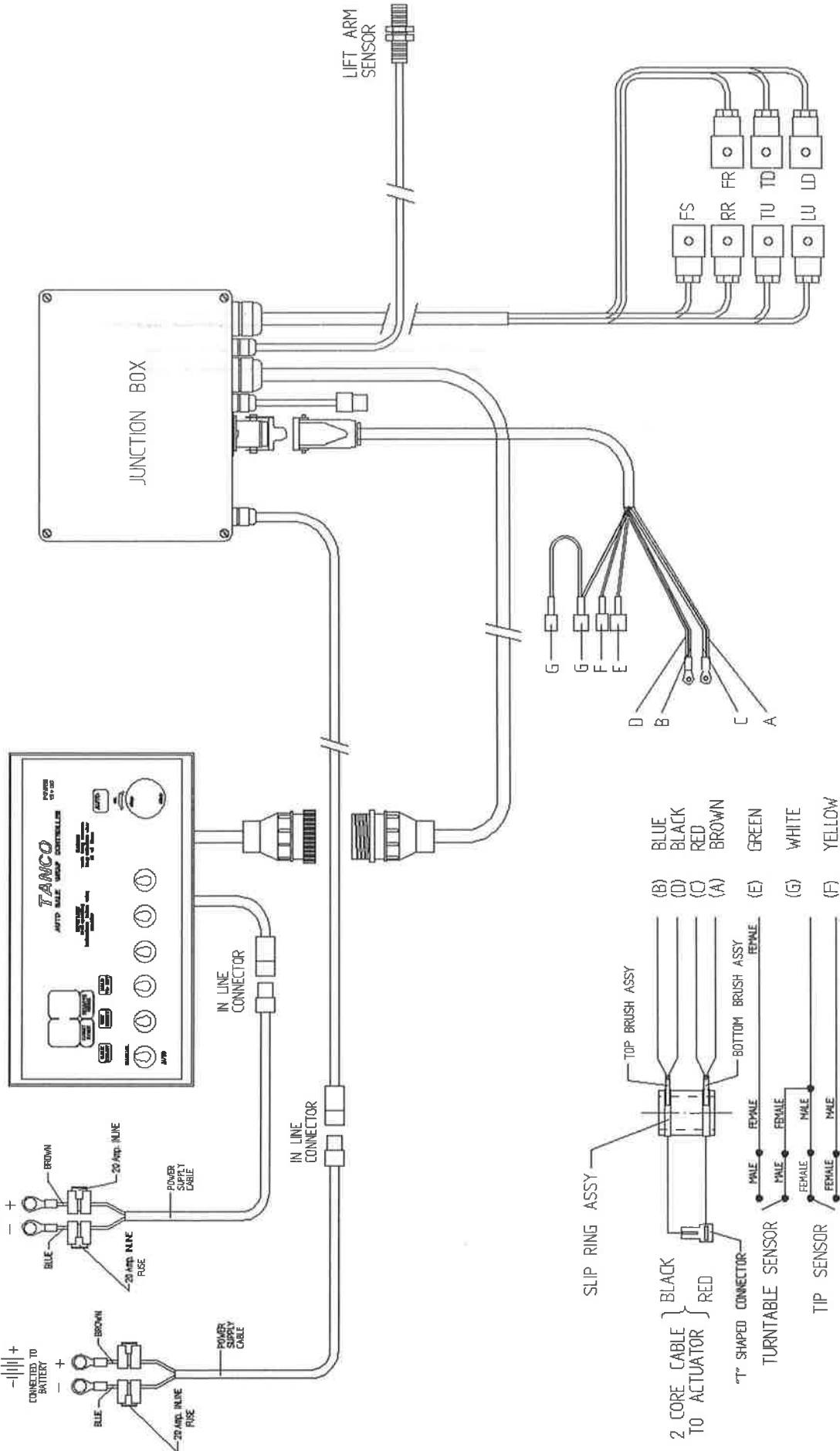

AUTOMATIC BALE WRAP CONTROLLER

The control unit on the 1994 Autowrap allows full automated control of the bale wrapping sequence. The control unit is pre-programmed to automatically wrap the bale to the required number of revolutions. Once complete, the turntable stops in the correct position to allow the film to be cut and held. Incorporated is also an inching override facility on the control unit to move the turntable, left or right, to ensure that the film is properly gathered. Once the turntable is lowered it rotates automatically back through 90 degrees to facilitate loading the next bale. Loading and tipping off of the bale is operator controlled using switches on the control unit.

The programming of the Automatic Bale Wrap Controller is easily done by following the steps outlined below.

Once the unit is switched on, the number of required turntable revolutions appears on the right hand display. To change this press and hold the "hold to set" button, see fig 1., then press the "set/reset" button. The first digit of the number will then blink and count from 0-9. Release the "set/reset" button at the required number. By pressing the "set/reset" again the second digit can be changed.

The monitor counts the number of bales per batch and the cumulative total. To see these, press the "bale count" button. The first number to appear is the batch total. If the button is held down for 10 seconds, a line will appear on the display, followed by the cumulative number wrapped. The batch count can be reset to 0 by holding the "bale count" button down and pressing the "set/reset" once. The cumulative total cannot be returned to zero.

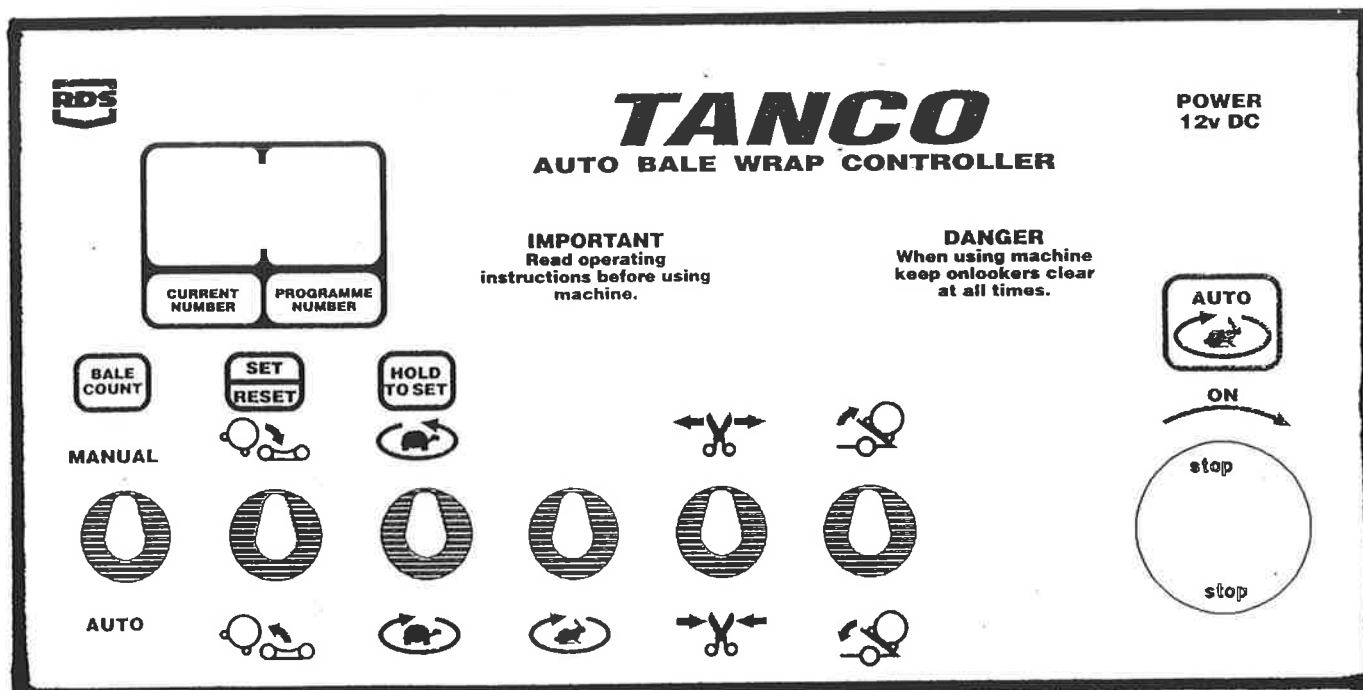

OPERATOR ACCESSIBLE MONITOR PROGRAMMES

The Auto Bale Wrap Controller display a total of *8 programmes. To access the programming mode, turn the power off by pressing the red button, then press and hold the 'hold to set' key and turn the power on, by rotating the red button. Now you have accessed to the programming mode. A chevron 'V' will appear in the left side of the left display - this indicates the first function. By pressing the 'hold to set' key the next programme is accessed and so on. The chevron 'V' will move across the display indicating each of the 8 functions. The functions and settings are as follows.

Programme 1: Park Position
Display Reading: 5.5 Seconds



Function: Time required for the 'Cut and Start' Actuator to return from the 'Open' position to the 'Park' position (See Diagram).

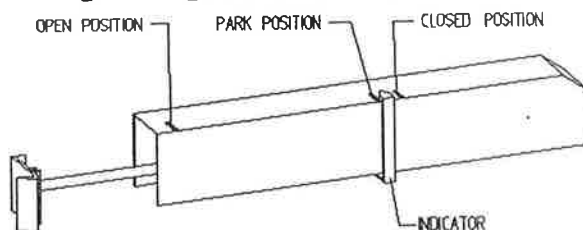

Due to varied output from tractor batteries, this reading may have to be altered to ensure that the indicator arm stops at the 'park' position.

- (i) If the indicator arm passes the 'park' position, then reduce the valve by 0.1 sec. Repeat this until correct.
- (ii) If the indicator arm does not reach the 'park' position, then increase the valve by 0.1 seconds until corrected.

Programme 2: Stop Position for the Cut and Start
Display Reading: 0.3 seconds.

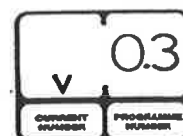

Function: This programme sets the point at which the 'Cut and Start' stops under the film at the end of the automatic wrapping cycle. This Value is adjusted.

- (i) If the turntable rotates too far and the 'Cut and Start' passes under, then reduce the setting by 0.1. Repeat until corrected.
- (ii) If the turntable rotate does not far enough and the 'Cut and Start' does not line up with the film, then increase the setting by 0.1. Repeat until corrected.

* NOTE: Automatic autowrap controllers prior to Serial No. 45700 had only 7 programmes displayed. After this serial number **Programme 4** "Tip to Tip Down Delay" was inserted to give more control to the operator for fine tuning the automatic sequence.

Programme 3: Tip up.
Display reading: 4.0

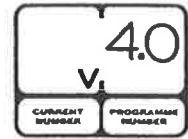

Function: This controls the time for which the tipping ram extends out after the 'Cut and Start' closes. This value is changed only when the setting of the rear magnet that impulses the tip sensor, is changed;

- (i) If the magnet is adjusted upwards then this setting will have to be increased.
- (ii) If the magnet is adjusted downwards then this setting is decreased. Adjustment is in 0.5 second increments.

Programme 4: Tip up to tip down delay
Display reading: 0.5



Function: Duration in seconds that the tipping ram remains fully extended between tip up and tip down.

Programme 5: Tip down.
Display reading: 4.8



Function: This controls the time required for the turntable to tip down to the horizontal position. Note: this setting is increased if the film pull down arm does not retract fully. Adjust in 0.1 increments.

Programme 6: Stop Position in Reverse.
Display Reading: 0.3

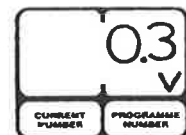

Function: This controls the point at which the turntable will stop when it rotates back to facilitate loading. This setting is only altered;

- (i) When the turntable rotates back too far then decrease this value by 0.1. Repeat until corrected.
- (ii) When the turntable does not rotate back enough then increase this value by 0.1. Repeat until corrected.

Programme 7: Machine Operation.

There are four separate settings for this programme depending on how the machine is being used. Two settings apply to the remote control models and two to the non remote models.

Remote control mode with 90 degrees reverse not operational = Symbol r.

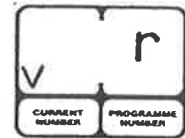

Remote control mode with 90 degrees reverse operational = Symbol R.

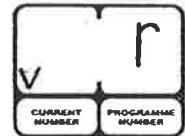

Non remote mode without 90 degrees reverse operational = Symbol o .

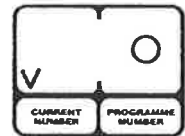

Non remote control mode with 90 degrees reverse operational = Symbol O.

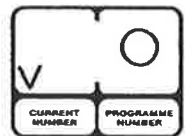

Programme 8: Tractor hydraulics.

Designed to convert the hydraulic system to suit open or closed centre hydraulics to tractor;

Closed centre = Symbol J

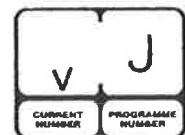

Open centre = Symbol n.

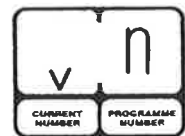

NOTE: An additional valve is required for operating in the J mode.

MODE OF OPERATION

Automatic Mode;

1. Lower bale lift arm to correct position and pick up the bale.
2. Position the bale gently onto the turntable with a grab ensuring that it is central between the end rollers.
3. Once loaded, the arm is lowered and the 'Auto Start' button is pressed to commence wrapping. **NOTE:** The table must be in the correct loading position before the 'Auto Start' button is pressed. If not the table may stop in the wrong position at the end of wrapping.
4. In the automatic cycle the turntable will start off slowly for a half of one revolution before it reaches full speed. On the last revolution it will slow down and stop in the correct position to allow the film to be cut and held. **NOTE:** It is possible to move the turntable, left or right, to align the plastic by using the remote control or the toggle switch.
5. During the wrap cycle the 'Cut and Start' will extend out automatically. An indicator on the outside panel indicates what stage the 'Cut and Stat' is at. On the third revolution the actuator extends out moving the indicator from the close position to the open position. On the sixth revolution the actuator returns to the park position indicating that the 'Cut and Start' is ready to close. The indicator must be at the park position in either manual or automatic mode before the 'Cut and Start' will close.
6. When in a safe position to do so, press the tip off button.
7. The tip off sequence is automatic and once the turntable lowers it will rotate backwards through 90 degrees to facilitate loading, if required.

Manual Mode:

1. Switch to manual on the monitor.
2. Load the bale as outlined above.
3. Using the slow rotation switch, start the wrapping cycle.
4. After half of a revolution, switch to the fast wrapping mode by pressing the appropriate switch.
5. During the wrapping extend the Cut and Start out to the end mark and return the indicator to the 'Park Position'.
6. At the end of the wrap cycle line up the 'Cut and Start' with the film.
7. When safe to do so, tip off the bale and lower the turntable.
8. Position the turntable to load the next bale.

OPERATING INSTRUCTIONS

1. Fit roll of film following the instructions on the film mast.
2. Pull off enough film to reach the cut and start gripper assembly.
3. Pull the plunger open and attach tag end of film between the gripper jaws.
4. Drop wrapper until skids just touch the ground.
5. Adjust top link until wrapper is level.
6. Lower the loading arm stabiliser skid until it touches the ground and pressure is off safety prop (8) Fig. 4 which should then be removed and stored on spigots on loading arm.
7. Lower loading arm until it just touches ground. Remove safety stay (7) Fig. 4 from storage spigots and refit it to spigot on chassis, ensuring slotted hole is fitted to end of lift ram pivot pin and secure with linch pins.
8. Locate bale on lift arm, then raise it and gently roll bale onto turntable. Lower arm.
9. Start wrapping, turntable rotating clockwise. Film tension is automatically set so that width of film applied to the bale stays at approx width of 405 - 410mm for 500mm wide film roll and 615 - 620 for 750mm wide film roll.
10. Continue wrapping until signal from bale wrap indicator sounds (required number of revolutions has been reached). Then stop with cut and start unit facing towards front of machine and film aligned with opened gripper section of cut and start.
11. Tip bale from machine. When the machine is almost fully tipped the cut and start unit grips and cuts the film and the bale is then unloaded onto the bale mat.
12. Lower the turntable and rotate anticlockwise through 90 degrees and stop with cut and start opposite to lift arm.
13. Repeat operations 8 - 12 as required.

NOTE: The film need only be attached at the start of a roll, after that, the sequence is automatic.

WARNING LIFT ARM

The Lift Arm on the trailed machine is designed to pick up and deposit bales onto the turntable prior to wrapping and to raise the machine while empty, to facilitate adjustment to sliding axle. It is not intended to be used or transporting bales over distances or for use as a stabiliser whilst wrapping.

Therefore any use of the lift arm outside its primary function will be deemed to be abuse and will void all warranty.

FILM OVERLAP SYSTEM.

The Autowrap is fitted as standard with the 2 x 2 x 50% film overlap system. This is achieved by means of a chain drive which ensures that the correct number of film layers are applied to the bale after a specific number of revolutions of the turntable. The number of revolutions required to wrap a bale depends on width of film being used and bale size - See table below. The chain to be positioned on outer sprockets for 500mm wide film, and on inner sprockets for 750mm wide film. See fig. A, Below.

For silage bales we recommend the application of a minimum of four layers of film.

Bale Size	Width of Film Roll	Bale Indicator Setting (Revs)
120cm x 120cm	500mm	22
120cm x 120cm	750mm	15
120cm x 137cm	500mm	24
120cm x 137cm	750mm	16
120cm x 150cm	500mm	26
120cm x 150cm	750mm	18

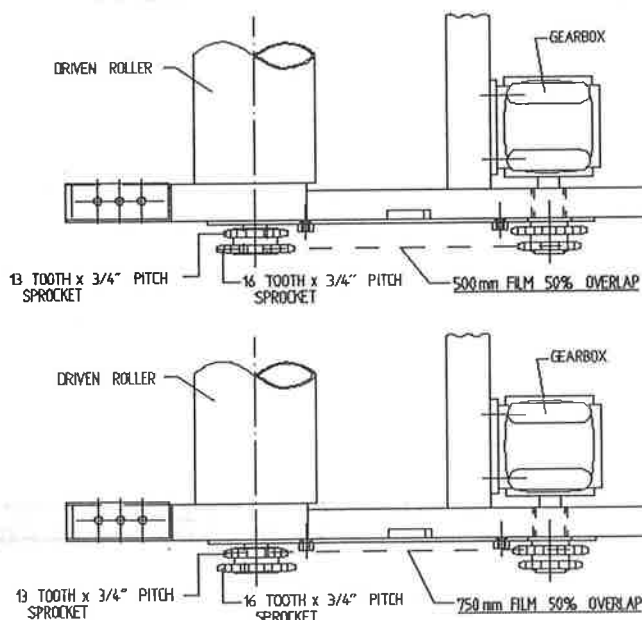

Fig. A

IMPORTANT

The above recommendations are only offered as a guide to correct wrapping of silage bales and the manufacturer accepts no responsibility for variations that may arise and the consequence of same. They are based upon turntable speeds of up to 25 r.p.m., and a minimum film width of 400mm applied to end of Bale when using 500mm wide film roll or a minimum film width of 600mm applied to end of bale when using 750mm wide film roll - See Page 14 proper maintenance of the machine and its correct operation.

It is the responsibility of the operator to ensure the correct number of wraps are applied, as variances can occur with fluctuations in speed of rotation, film quality and tensioning, shape and density of bale etc.

SERVICE AND MAINTENANCE

1. All nuts and bolts should be tightened after some hours in use and thereafter regularly.
2. Wheel pressure should be normally kept at 42 psi depending on bale weight and field conditions.
3. Inspect moving parts for wear on daily basis.
4. Remove hydraulic motor guard daily and clean loose materials from drive pulley and tensioner roller. Replace guard and lock in position while ensuring it does not collide with rotating turntable assembly.
5. Lubrication.

Drive chain & sprocket	-	grease every 24 hours.
End rollers	-	grease every 24 hours.
Main rollers	-	grease every 24 hours.
Hinge pins on Lift arm	-	grease every 24 hours.
Hinge pins on main tip frame	-	grease every 24 hours.
Hydraulic rams	-	grease every 24 hours.
Wheel bearings	-	grease every 24 hours.
Film reel assy.	-	grease every 24 hours.
Dispenser slave roller	-	oil every 24 hours.
Dispenser gearboxes	-	grease sparingly each month
Main spindle	-	grease every 4000 - 5000 bales.
Gearbox oil level	-	Check every 4000 - 5000 bales
6. Adjustments

Secondary drive chain tension.	:	Adjust after first days work then every 50 hours.
Primary drive chain tension	:	Adjust after first days work then check/adjust every 200 hours. See Fig 2.
Toothed drive belt	:	Adjust tension if slippage occurs See Fig 3.
Main conveyer belt	:	Adjust by moving idler roller up slope being careful to keep it parallel to the main drive roller.
7. Film Dispenser

Fit with plunger at top.
Apply one shot of Multi-Purpose Grease
Wash rollers often to avoid build up of Tack from film.
Follow Film threading diagram. See Fig 1.
8. Film Adjustment

Centre of film roll must be in line with centre of bale and film mast should be vertical.

SERVICE AND MAINTENANCE (CNT.)
HYDRAULIC FILTER

1. Before connecting Autowrap to tractor, change oil in tractor hydraulic system and replace hydraulic filter.
2. After 25 hours max. it will be necessary to replace the element in Autowrap filter.
3. For maintenance purposes it is necessary to change the element after 200 working hours.
4. The element cannot be just cleaned and put back into the filter. "

TANCO AUTOWRAP FILM THREADING DIAGRAM

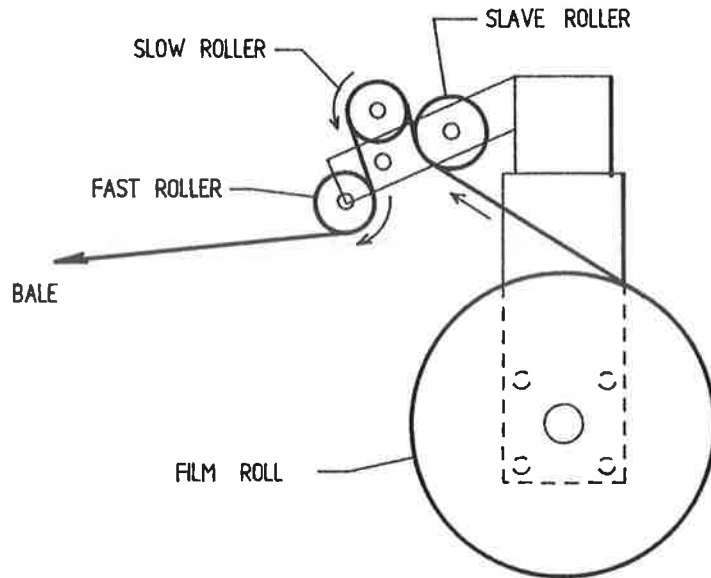

FILM ADJUSTMENT

CENTRE OF FILM ROLL MUST BE IN LINE WITH CENTRE OF BALE AND FILM MAST SHOULD BE VERTICAL.

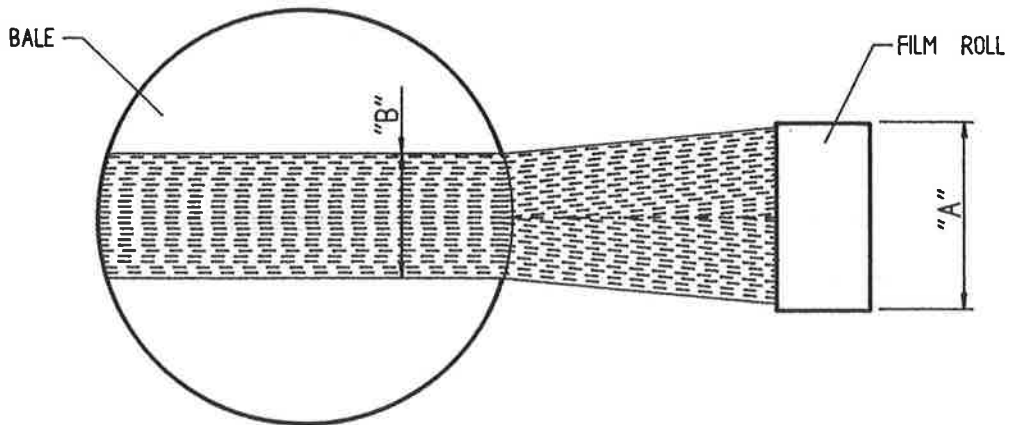

FILM ROLL WIDTH "A"	FILM WIDTH ON END OF BALE "B"
500 mm	400 mm
750 mm	600 mm

Fig. 1

FILE NAME W060-LA21

**TANCO AUTOWRAP CONSTANT INDEXING
PRIMARY CHAIN DRIVE TENSIONING SYSTEM**

CHAIN TENSIONING PROCEDURE

1. LOOSEN M10 BOLT SECURING BELT TENSIONER.
2. TENSION BELT BY ADJUSTING TENSIONER USING SPANNER IN DIRECTION OF ARROW "X" UNTIL SETTING OF 15"-20" IS REACHED.
3. RE-TIGHTEN M10 BOLT TO SECURE TENSIONER IN POSITION.

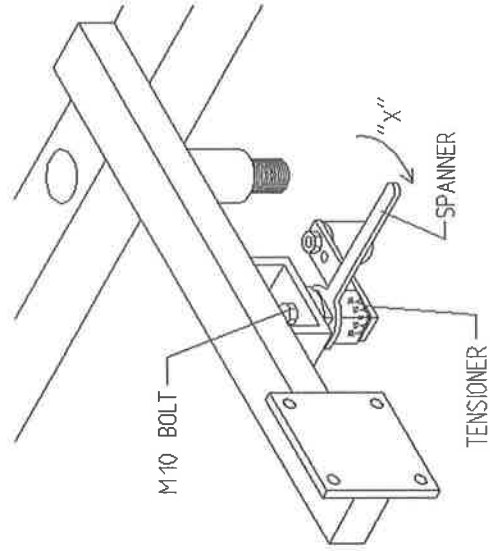
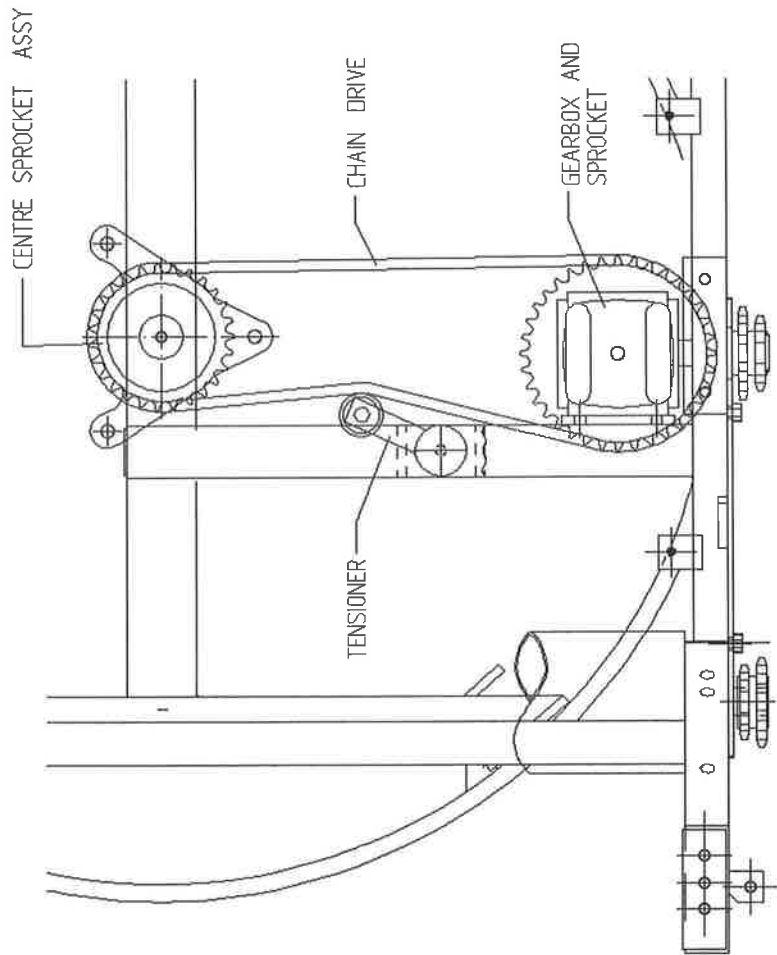

FIG. 2

TANCO AUTOWRAP 1994 DRIVE BELT TENSIONING SYSTEM

BELT TENSIONING PROCEDURE

1. CHECK THAT HYDRAULIC MOTOR MOUNTING BRACKET IS SECURE IN POSITION.
2. LOOSEN M10 BOLT WHICH CLAMPS BELT TENSIONER BODY TO MOTOR MOUNT.
3. TENSION BELT BY ADJUSTING TENSIONER USING SPANNER IN DIRECTION OF ARROW "X" UNTIL SETTING OF 30 IS REACHED.
4. RE-TIGHTEN M10 BOLT TO SECURE TENSIONER IN POSITION

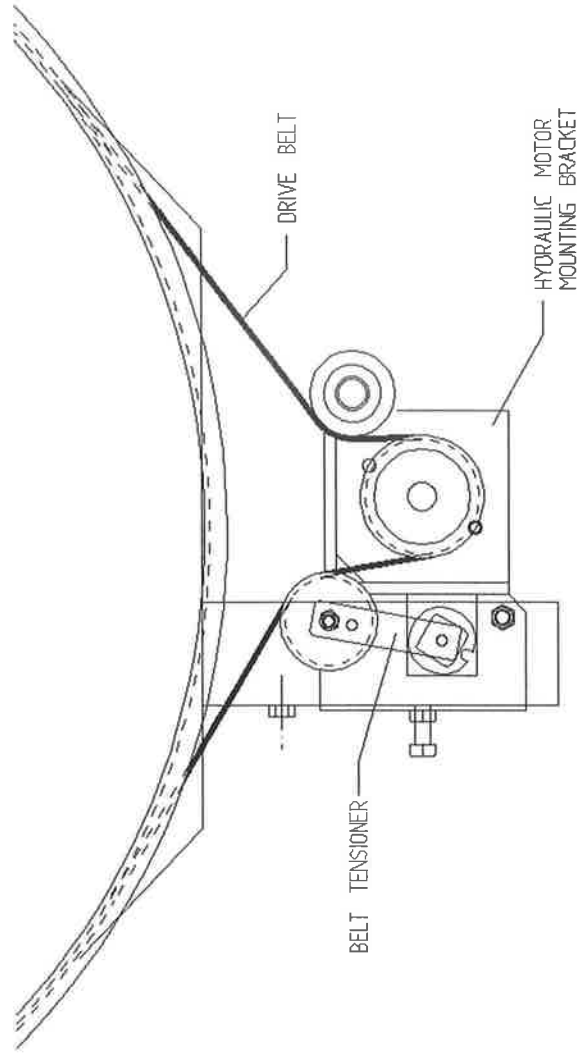
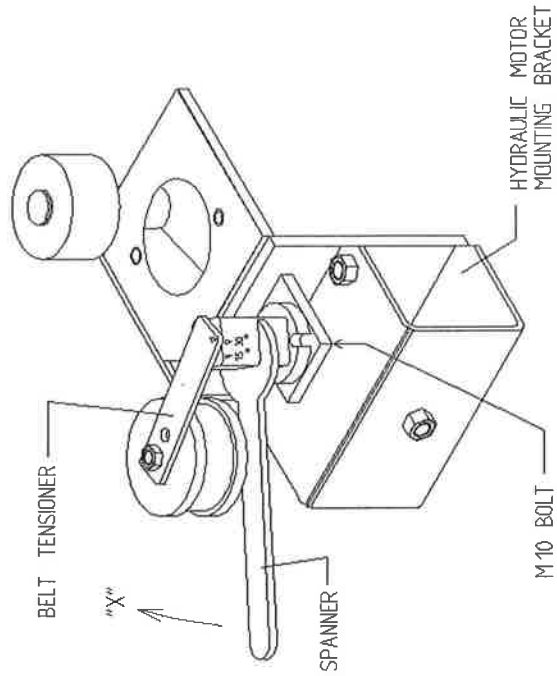

Fig. 3

FILM ADAPTOR

OPERATING INSTRUCTION

500mm wide film rolls are used as standard on 200, 300, & 400 autowrap Models while 750mm wide film rolls are used as standard on 500 model. If however, it is found necessary to use 500mm wide rolls along with 750mm film dispenser the following instructions must be adhered to: (NOTE: Failure to do so will result in inadequate wrapping and bale spoilage).

1. Fit film adaptor to top end of 500mm wide film roll as shown opposite (fig. 1.)
2. Remove drive chain from inner set of sprockets and fit to outer set of sprockets as shown in Fig. below.
3. Re-tension chain.
4. Adjust height of film mast so that centre of film roll is in line with centre of bale on the turntable.
5. Adjust bale wrap indicator setting from 15 to 22 revolutions for 120cm x 120cm blaes. (See page for guide to bale wrap indicator settings).

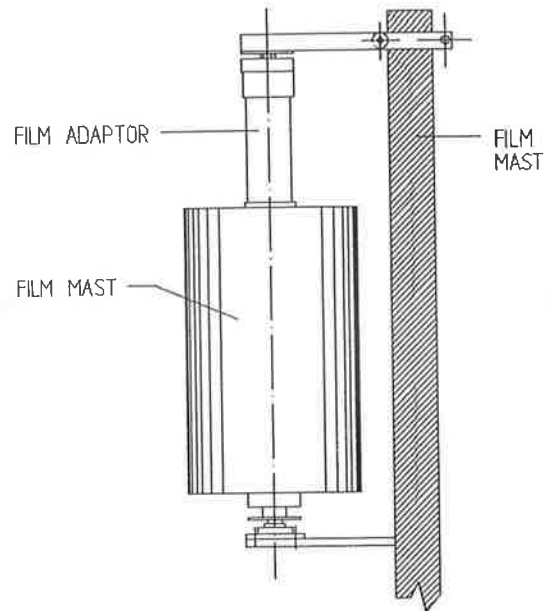
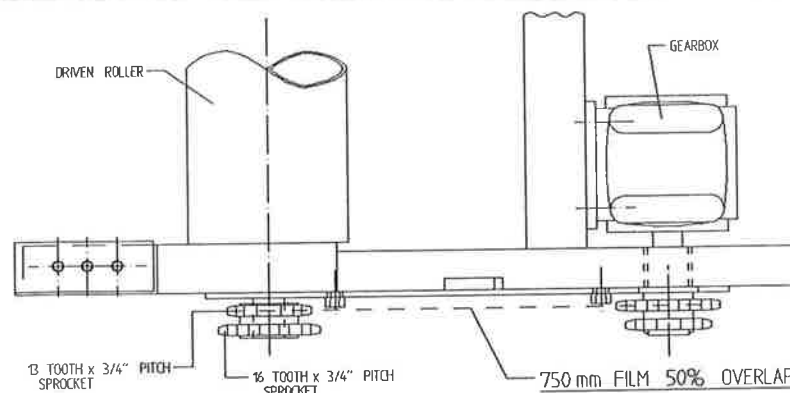
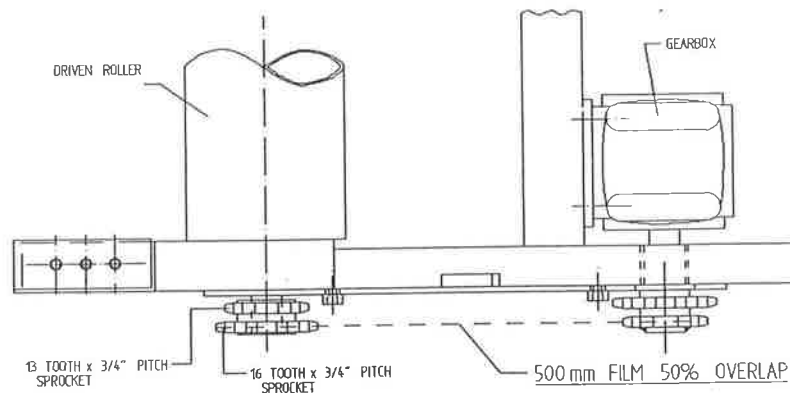
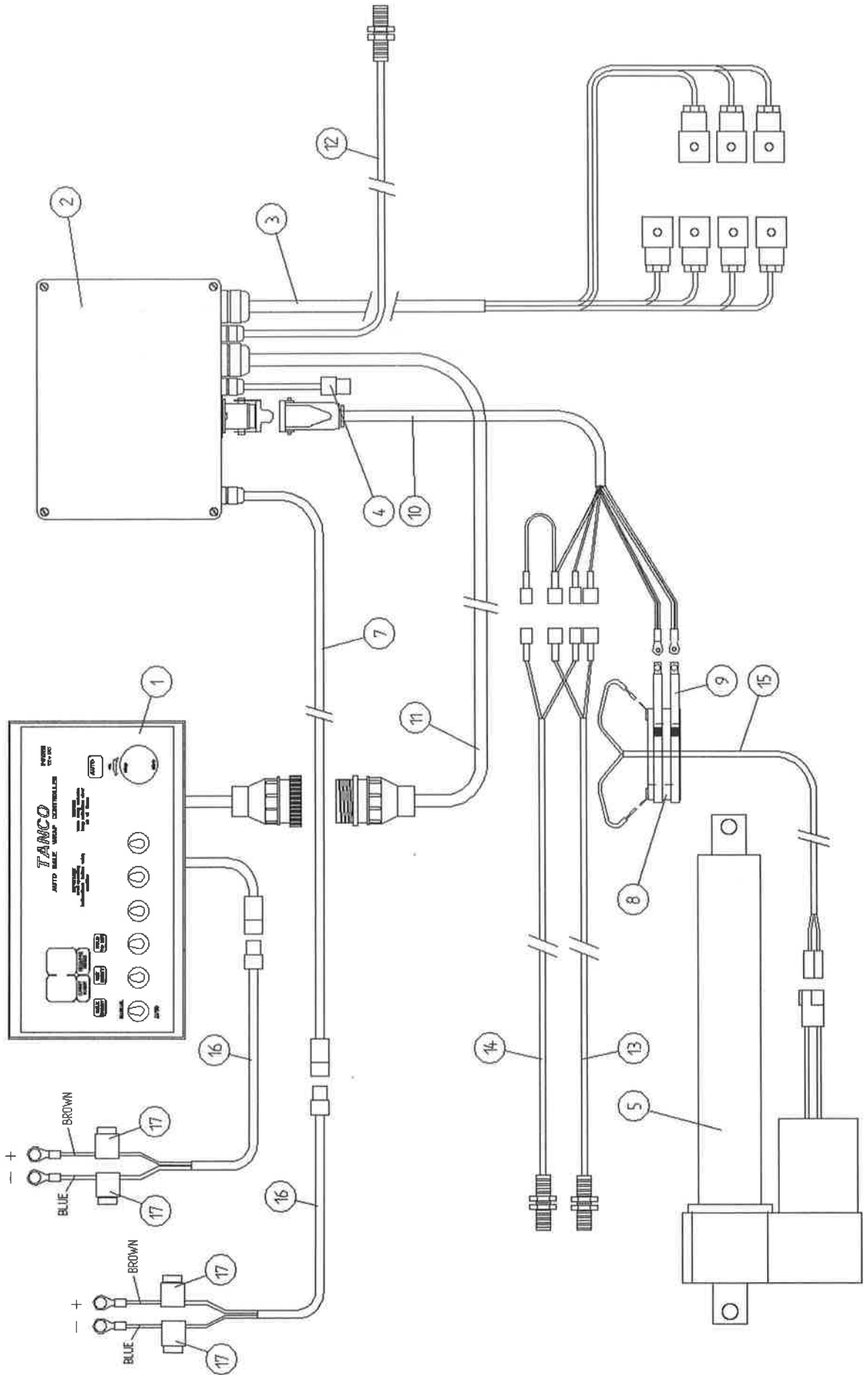

Fig. 1



TANCO AUTOWRAP 400A/500A/1050A MODELS
ELECTRICAL COMPONENTS



**TANCO AUTOWRAP 400A/500A/1050A MODELS
ELECTRICAL COMPONENTS
PARTS LIST**

ITEM NO	DESCRIPTION	QTY	PART-NO
1.	CONTROL BOX	1	D606
2.	JUNCTIN BOX (3BANK SPOOL VALVE)	1	ZDG-JB3
3.	LOOM FOR VALVE C/E HIRSCHMAN	1	ZD606-082
4.	SYSTEM PRESSURE LEAD	1	ZD606-070
5.	WRANER LINEAR ACTUATOR	1	ZD605-510
6.	1 1/4" FUSE HOLDER	1	ZD606-100
7.	MAIN LEAD FOR JUNCTION BOX	1	ZD606-050
8.	SLIP RING ASSY	1	ZD605-308
9.	BRUSHES	1	ZD605-302
10.	7 CORE CABLE C/W HEARTING PLUG	1	D605-7C
11.	24 CORE INTERCONNECTING LEAD C/W CONNECTORS	1	D605-24C
12.	LIFT ARM SENSOR	1	ZD606-LAS
13.	ROTATING SENSOR	1	ZD606-RS
14.	TIP SENSOR	1	ZD606-TS
15.	TWO CORE CABLE FOR SLIP RING	1	D605-02C
16.	MAIN BATTERY LEAD	2	ZD606-030
17.	IN-LINE FUSE	4	ZD606-100

TANCO AUTOWRAP 400 A MODELS (1994) HYDRAULIC CIRCUIT DIAGRAM

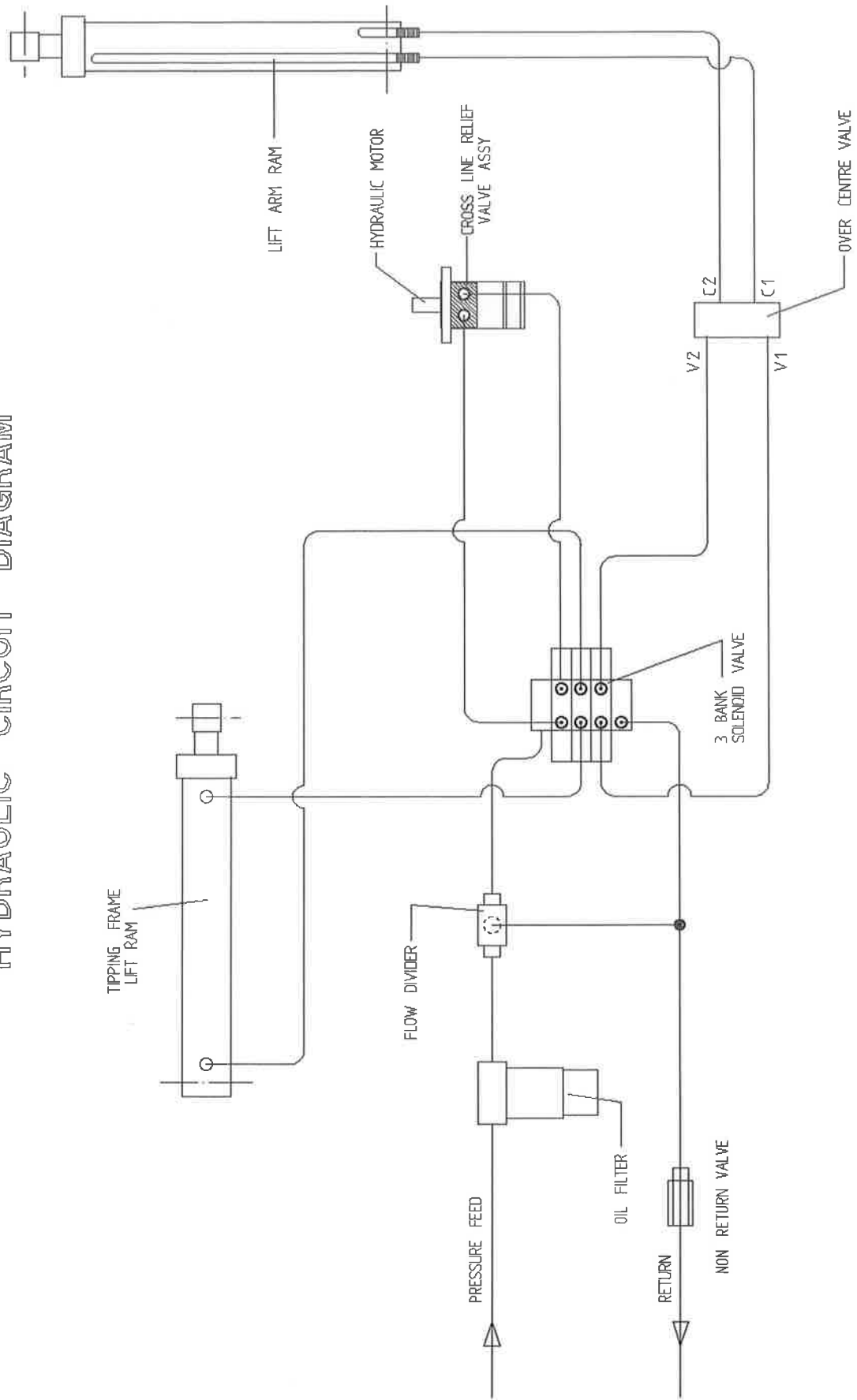

TANCO AUTOWRAP 500 A / 1050 A MODELS (1994) HYDRAULIC CIRCUIT DIAGRAM

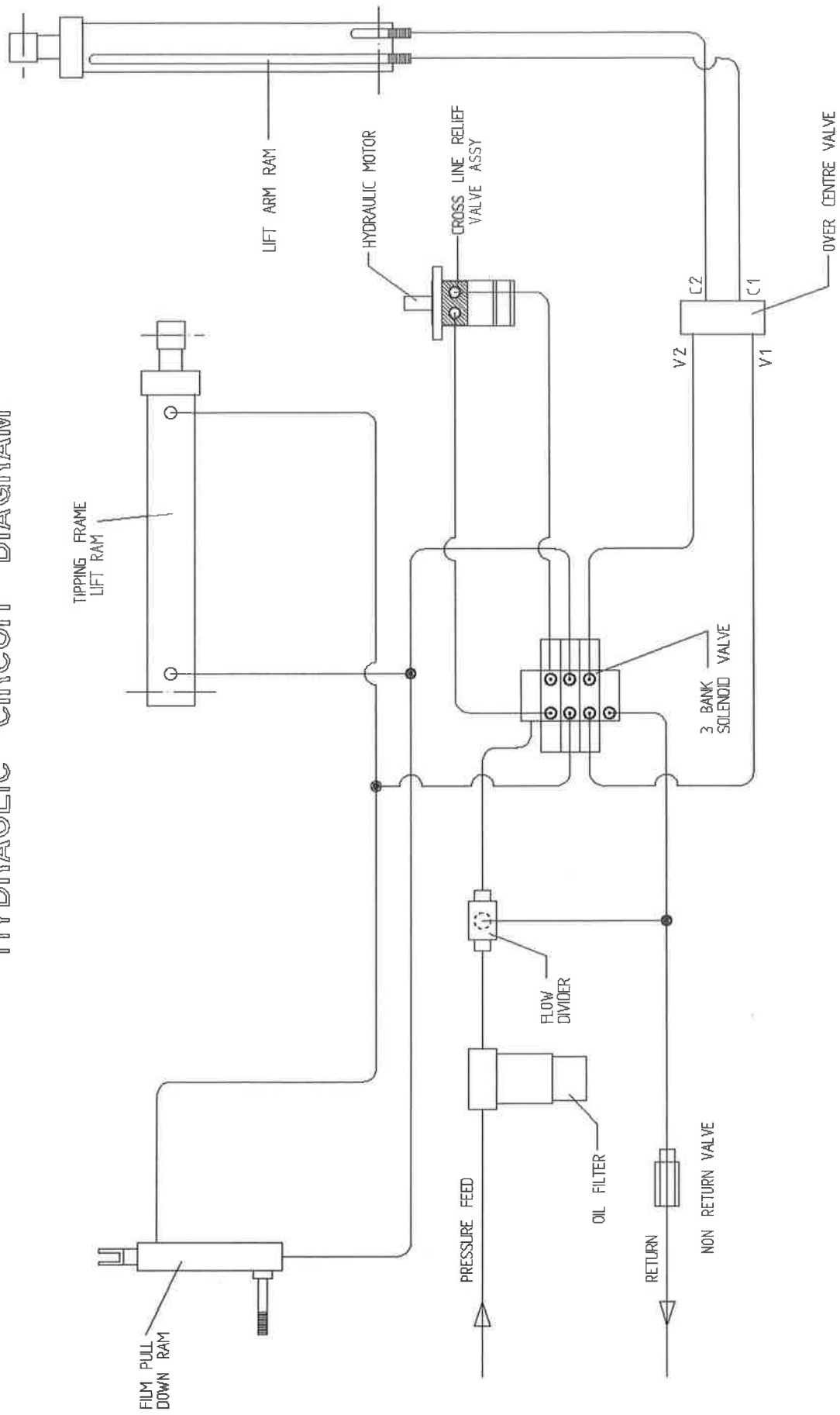

TANCO AUTOWRAP 400 A MODEL (1994)
HYDRAULIC COMPONENTS

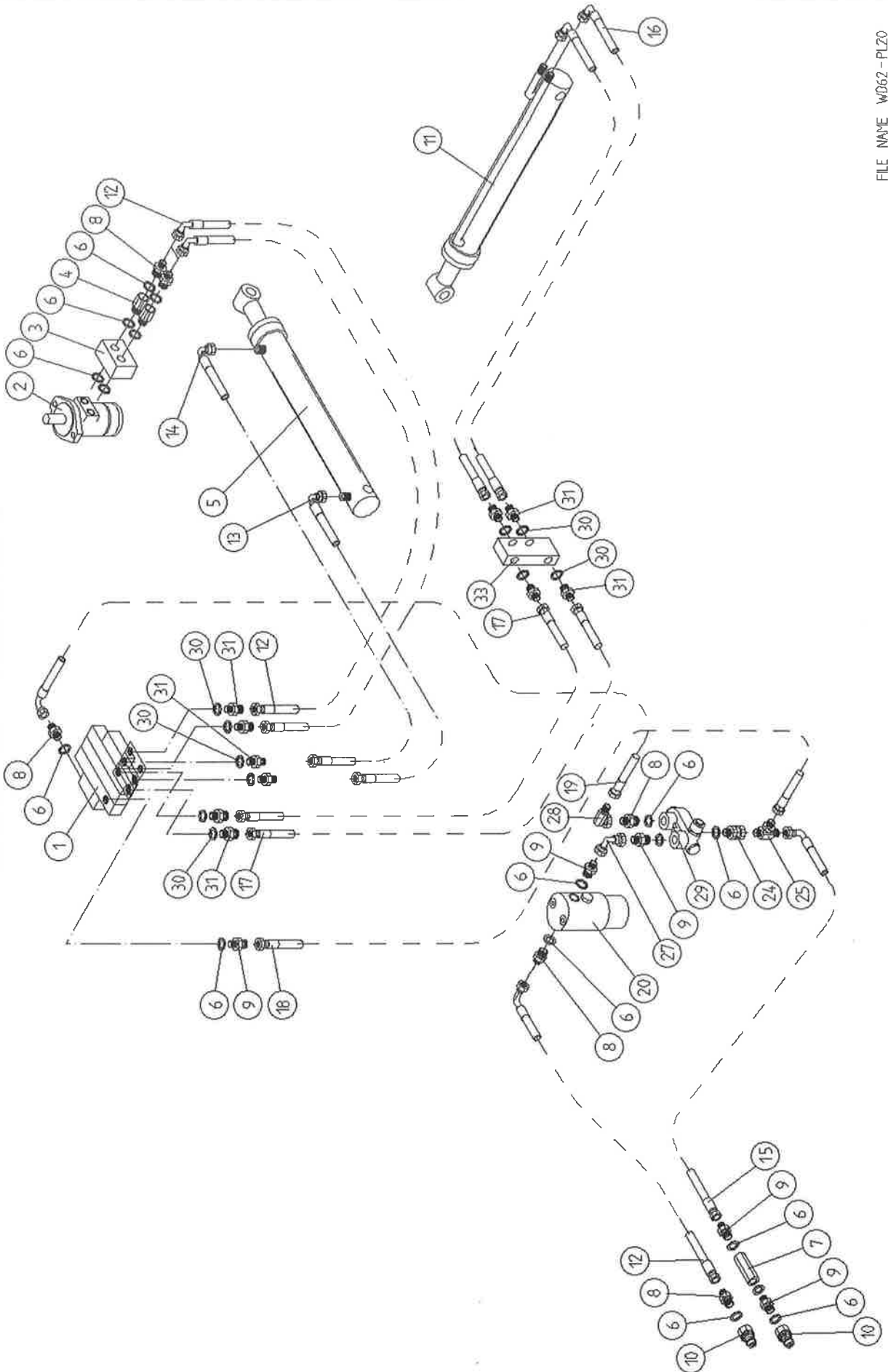

FILE NAME W062-PL20

TANCO AUTOWRAP 400A MODEL (1994)
HYDRAULIC MOTOR

PARTS LIST

ITEM NO	DESCRIPTION	QTY	PART-NO.
1.	3 BANK SOLENOID VALVE	1	Z01-03-10-A3
2.	HYDRAULIC MOTOR C.L.	1	Z01-02-ARY5
3.	CROSS LINE RELIEF VALVE	1	Z01-03-002
4.	1/2" B.S.P. BOTTOM BANJO BOLT (SPECIAL)	2	Z01-18-081
5.	HYDRAULIC RAM (TIPPING FRAME)	1	Z01-01-R687
6.	1/2" DOWTY WASHER	16	Z01-04-03
7.	1/2" NON RETURN VALVE	1	Z01-03-017
8.	1/2" x 3/8" ADAPTOR	6	Z01-06-06-08
9.	1/2" X 1/2" ADAPTOR	5	Z01-06-08-08
10.	1/2" MALE END Q/R COUPLING	2	Z01-15-081
11.	HYD. RAM (FOR LIFT ARM)	1	Z01-05-AW
12.	96" ST/90 3/8" D/W HOSE	2	Z38-R2-96-S9
13.	60" ST/90 3/8" D/W HOSE	1	Z38-R2-60-S9
14.	72" ST/90 3/8" D/W HOSE	2	Z38-R2-72-S9
15.	96" ST/90 1/2" D/W HOSE	1	Z12-R1-96-S9
16.	120" ST/90 3/8" D/W HOSE	2	Z38-R2-120S9
17.	17" ST/90 3/8" D/W HOSE	2	Z38-R2T-17SS
18.	24" ST/90 1/2" D/W HOSE	1	Z38-R1-24-S9
19.	24" ST/90 3/8" D/W HOSE	1	Z38-R2-24-35
20.	FILTER	1	Z01-24-08
24.	1/2" MALE X 1/2" FEMALE ADAPTOR	1	Z01-05-08-08
25.	1/2" MALE "T" PIECE	1	Z01-11-003
26.	OVER CENTRE VALVE	1	Z01-03-10-A8
27.	3/8" MALE/FEMALE 90 ELBOW	3	Z01-14-015
28.	3/8" MALE/FEMALE 90 ELBOW	3	Z01-14-015
29.	IN LINE FLOW DIVIDER	1	Z01-03-10-A7
30.	3/8" DOWTY WASHER	10	Z01-04-02
31.	3/8" X 3/8" ADAPTOR	10	Z01-06-06-06

TANCO AUTOWRAP 500 A/1050 A MODEL (1994)
HYDRAULIC COMPONENTS

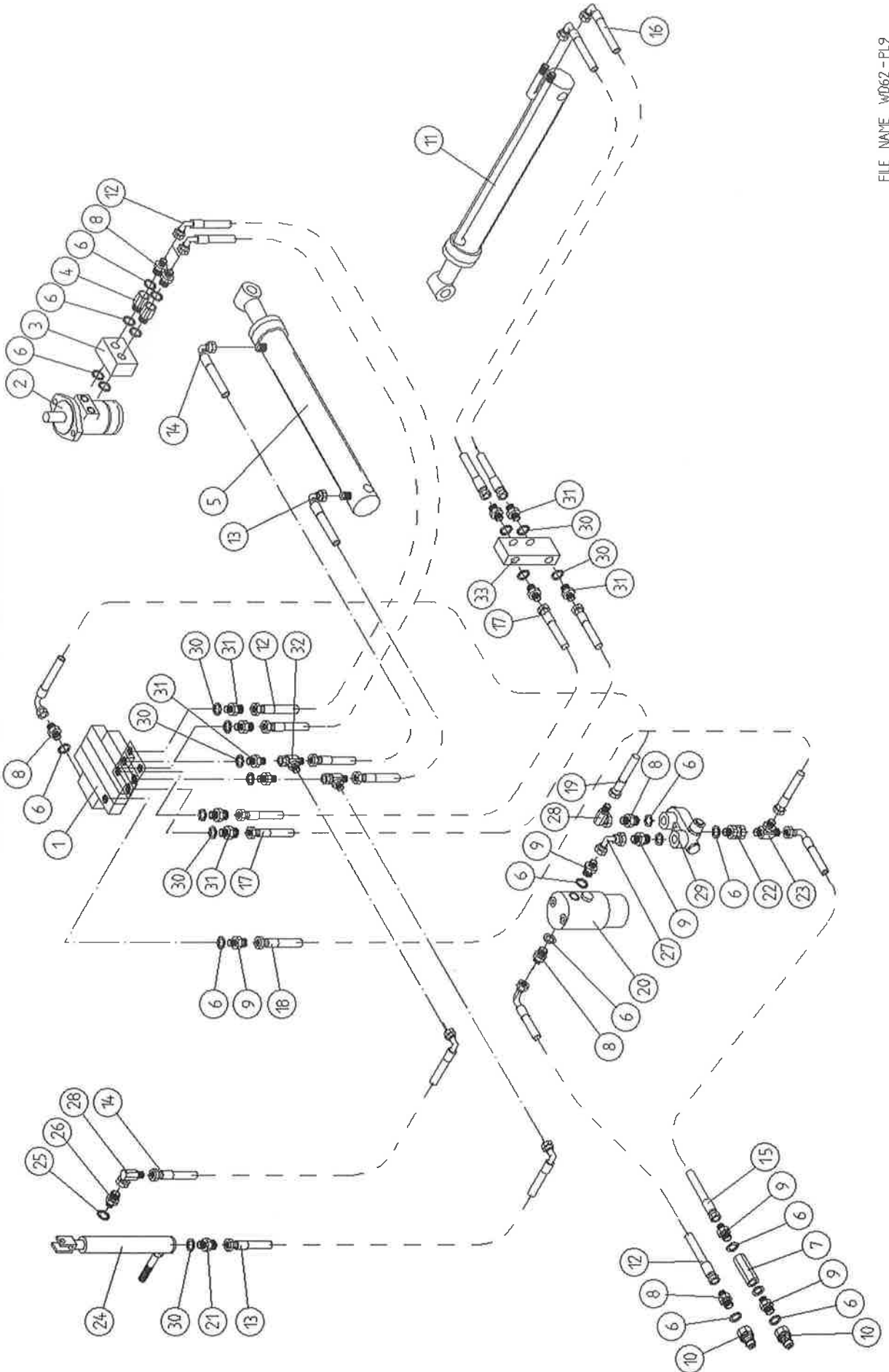

TANCO AUTOWRAP 500A/1050A MODELS (1994)HYDRAULIC COMPONENTSPARTS LIST

ITEM NO.	DESCRIPTION	QTY	PART-NO.
1.	3 BANK SOLENOID VALVE	1	Z01-03-10-A3
2.	HYDRAULIC MOTOR C.L.	1	Z01-02-AR75
3.	CROSS LINE RELIEF VALVE	1	Z01-03-002
4.	1/2" B.S.P. BOTTOM BANJO BOLT (SPECIAL)	2	Z01-03-002B
5.	HYDRULIC RAM (TIPPING FRAME)	1	Z01-01-AR687
6.	1/2" DOWTY WASHER	17	Z01-04-03
7.	1/2" NON RETURN VALVE	1	Z01-03-017
8.	1/2" X 3/8" ADAPTOR	6	Z01-06-06-08
9.	1/2" X 1/2" ADAPTOR	5	Z01-06-08-08
10.	1/2" MALE END Q/R COUPLING	2	Z01-15-081
11.	HYD. RAM (FOR LIFT ARM)	1	Z01-01-AW
12.	96" ST/90 3/8" D/W HOSE	3	Z38-R2-96-S9
13.	60" ST/90 3/8" D/W HOSE	2	Z38-R2-60-S9
14.	72" ST/90 3/8" D/W HOSE	2	Z38-R2-72-S9
15.	96" ST/90 1/2" D/W HOSE	1	Z12-R1-96-S9
16.	120" ST/90 3/8" D/W HOSE	2	Z38-R2-120S9
17.	16" ST/ST 3/8" D/W HOSE	2	Z38-R2T-17SS
18.	24" ST/ST 1/2" D/W HOSE	1	Z12-R2-24-SS
19.	24' ST/90 3/8" D/W HOSE	1	Z38-R2-24-S9
20.	FILTER	1	Z01-24-08
21.	3/8" X 3/8" ADAPTOR FITTED WITH 0.06" RESTRICTOR.	1	Z01-03-40
22.	1/2" MALE X 1/2" FEMALE ADAPTOR	1	Z01-05-08-08
23.	1/2" MALE "T" PIECE	1	Z01-11-003
24.	HYD. RAM D/A (PULL DOWN ARM)	1	Z01-01-AW25
25.	1/4" DOWTY WASHER	1	Z01-04-01
26.	1/4" X 3/8" ADAPTOR	1	Z01-06-04-06
27.	1/2" FEMALE X 1/2" FEMALE 90 ELBOW	1	Z01-14-018
28.	3/8" MALE/FEMALE 90 ELBOW	2	Z01-14-015
29.	IN LINE FLOW DIVIDER	1	Z01-03-10-A6
30.	3/8" DOWTY WASHER	11	Z01-04-02
31.	3/8" X 3/8" ADAPTOR	10	Z01-06-06-06
32.	3/8" MALE X 3/8" MALE X 3/8" FEMALE "T" PIECE	2	Z01-12-002
33.	OVER CENTRE VALVE	1	Z01-03-10-A8

**INSTRUCTION FOR FITTING TWO WAY SOLENOID VALVE TO TANCO
AUTOWRAP MODELS 400A, 500A, 1050A, 1250A.**

**REQUIRED WHEN OPERATING MACHINES ON TRACTORS WITH CLOSED CENTRE
HYDRAULIC SYSTEMS.**

1. Disconnect st/90 hose from inlet port on oil filter.
2. Connect port "T" on solenoid valve assembly to inlet port on oil filter.
3. Reconnect st/90 hose to port "P" on solenoid valve.
4. Connect 2 pin female connector to existing 2 pin connector at junction box.
5. Change the seventh controller function setting from n to J. See instruction manual for further information.

**TANCO AUTOWRAP 400A/500A/1050A/1250A MODEL (1994)
TWO WAY SOLENOID VALVE KIT PART NO. Z01-03-018A**

PARTS LIST			
ITEM NO	DESCRIPTION	QTY	PART NO.
1	TWO WAY SOLENOID VALVE	1	Z01-03-10-A9
2	1/2" DOWTY WASHER	2	Z01-04-03
3	3/8" FEMALE x 1/2" MALE ADAPTOR	1	Z01-05-06-08
4	3/8" MALE/FEMALE 90 ELBOW	1	Z01-14-015
5	1/2" x 3/8" ADAPTOR	1	Z01-06-06-08

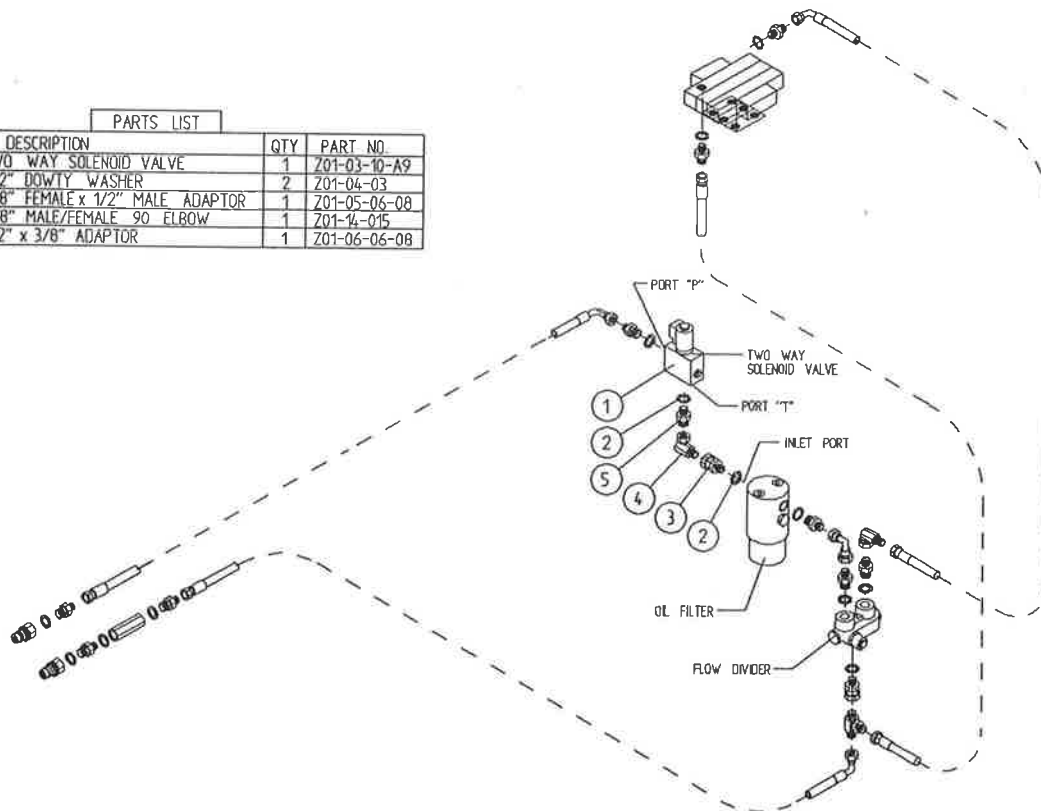

FILE NAME 9228C